

PRESS METAL ALUMINIUM

Press Metal Aluminium (Australia) Pty Limited
www.pmaa.net.au



COMMERCIAL & ARCHITECTURAL SYSTEMS REFERENCE GUIDE



AUSTRALIAN
GLASS &
WINDOW
ASSOCIATION

MEMBER OF THE AUSTRALIAN
GLASS & WINDOW ASSOCIATION

SYSTEMS SUPPORTED BY:



&



ISSUE - NOVEMBER 2022

PRESS METAL ALUMINIUM (AUSTRALIA) PTY LTD

HEAD OFFICE: 1012-1016 Canley Vale Road, Wetherill Park, NSW, 2164,

Sales - Administration: Tel: (02) 9756 5555 Fax: (02) 9756 5499

E-Mail: sales@pmaa.net.au

MELBOURNE: 32 Southeast Boulevard, Pakenham, VIC, 3810

Sales - Administration: Tel: (03) 9776 9976 Fax: (03) 8962 1060

E-Mail: vicsales@pmaa.net.au

BRISBANE: 43 Motorway Circuit, Ormeau, QLD, 4208

Sales - Administration: Tel: (07) 5540 6100 Fax: (07) 5540 6144

E-Mail: sales@pmaa.net.au

Press Metal Berhad (PMB) is a Multinational Corporation with headquarters in Kuala Lumpur, Malaysia, as well as operations in the United Kingdom, Australia, Hong Kong and Dubai. The Company was incorporated in 1986 and subsequently listed on the Kuala Lumpur Stock Exchange in 1993. PMB Technology Berhad, its subsidiary company, also became a public company in 2003.

PMB specializes in Aluminium Extrusion manufacturing and is one of the Largest produces in Southeast Asia. PMB Facade Sdn Bhd (Malaysia) and PMB-Cyberwall Ltd (Hong Kong), both under PMB Technology Berhad are Leading Curtain Wall Contractors in this region with an Excellent Track Record. The projects involved include many famed buildings such as Chep Lak Kok Airport (Hong Kong), Plaza 66 (Shanghai, China), Golden Hall (Macao) and a1 Bidda (Doha, Qatar) and so on.

Through continuous growth in the past Twenty Years, PMB has emerged to be an internationally well recognized establishment. To fulfill its aggressive expansion plan, it has relocated its major production facility to china by setting up Press metal international Ltd in Foshan, China in 2005. The factory sits on a 760,000m² area of land which will house a complete aluminium extrusion facility with eventual production capacity of 200,00 tonnes per annum.

Press Metal Aluminium (Australia) Pty Ltd, is part of the Press metal Berhad (PMB) Group and is the Australian Distributer for all Aluminium Extrusions Manufactured by the group.

The Window and Sliding Door products shown in this catalogue are all Australian Designed and Australian Tested, to compliance with the Relevant Australian Standards.

COPYRIGHT PROTECTED: The contents of this catalogue including all profile & section drawings, specifications, testing & performance data are registered and copyright protected and cannot be transferred, copied or duplicated in any shape or form without written permission from Press Metal Aluminium (Australia) Pty Ltd.

Cover Picture: 2018 Commonwealth Games Athletes Village - Parklands - Gold Coast - Queensland
Builder: Grocon **Fabricator / Installer:** Queensland Glass
PMAA Systems: 2000 and 3000 Series Windows and Doors



SUB FRAMES

PM 386
67mm SUB HEAD
Pg-01,50

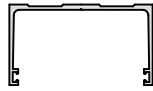

PM 139
100mm SUB HEAD
Pg-04



PM 720
100mm L/W SUB HEAD
Pg-04



ME2-51715
100mm L/W SUB HEAD
Pg-04



PM 141
SUB HEAD
BEAD
Pg-04

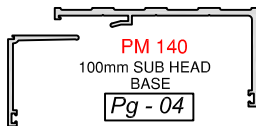

PM 140
100mm SUB HEAD
BASE
Pg - 04

PM 289
100 x 85mm SUB HEAD
Pg-05

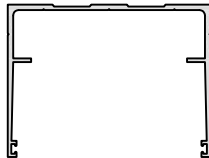

PM 269
SUB HEAD BRACE
Pg-05

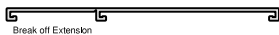

PM 267
100 x 105mm SUB HEAD
Pg - 05

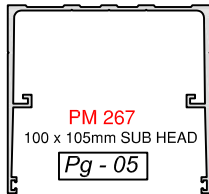

PM 796
128mm SUB HEAD
Pg-07



PM 297
150mm SUB HEAD
Pg-07

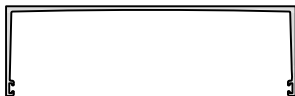

PM 299
150mm SUB HEAD
Page-07



PM 300
150mm SUB HEAD
BASE
Pg-07

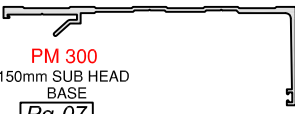

PM 141
SUB HEAD
BEAD
Pg-04,06,10,56

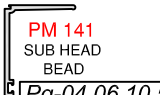

PM 326
164mm SUB HEAD BASE
Pg-10,56

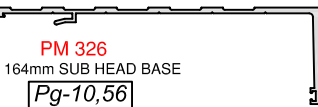

PM 287
200mm SUB HEAD BASE
Pg-11

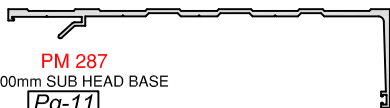

PM 385
67mm SUB SILL
Pg-01,50

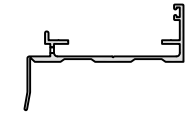

PM 224
100mm SUB SILL
Pg-02,67

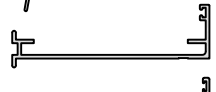

PM 746
100mm SUB SIL
Pg-02

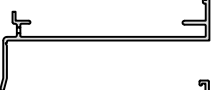

PM 145
100mm SUB SILL
Pg-02

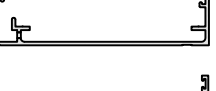

PM 706 & PM747
100mm SUB SILL
Pg-02

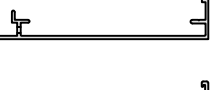

PM 745
100m SUB SILL
Pg-03

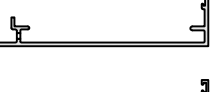

PM 790
100m SUB SILL
Pg-03

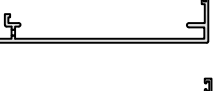

PM 294
100mm SUB SILL
Pg-03

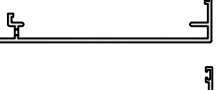

PM 798
100mm SUB SILL
Pg-02

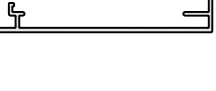

PM 296
150mm SUB SILL
Pg-08

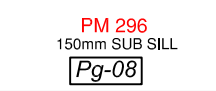

PM 144
12mm
EXTENSION
Pg-03,08,10

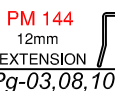

PM 142
100m SUB SILL
Pg-03

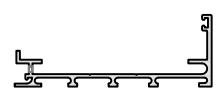

PM 143
40mm
EXTENSION
Pg-03,08,10

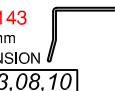

PM 302
150mm SUB SILL
Pg-08

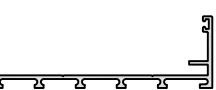

PM 154
65mm
EXTENSION
Pg-03,08,10



PM 327
164mm SUB SILL
Pg - 10,56

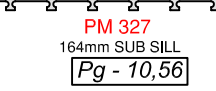

PM 288
200mm SUB SILL
Pg-11



PATH 113
100mm
SUB HEAD
Pg-06



PATH 136
150mm
SUB HEAD
Pg-09



PATH 114
100mm
SUB HEAD BASE
Pg-06



PATH 137
150mm
SUB HEAD BASE
Pg-09



PM 141
SUB HEAD
BEAD
Pg-04,06,10,56

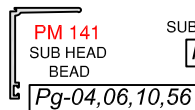

PATH 115
100mm
SUB SILL
Pg-06

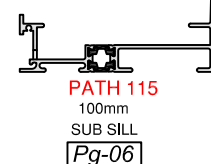

PATH 138
150mm
SUB SILL
Pg-09

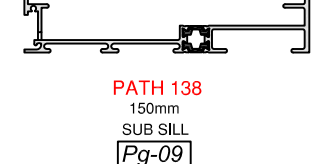



2001 - 2002 - 2003 SERIES

PM 380
18mm POCKET
67mm FRAME
Pg - 112

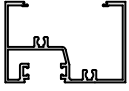

PM 384
18mm POCKET
67mm TRANSOM
Pg - 112

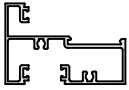

PM 381
18mm POCKET
67mm SILL
Pg - 112

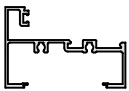

PM 379
18mm POCKET
67mm BEAD
Pg - 112



PM 336
18mm POCKET
67mm FEMALE MULLION
Pg - 112



PM 337
18mm POCKET
67mm MALE MULLION
Pg - 112



PM 389
18mm POCKET
67mm TRANSOM ADAPTOR
Pg - 112



PM 757
23mm POCKET
67mm FRAME
Pg - 12

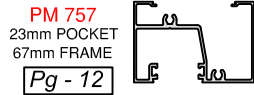

PM 763
67mm TRANSOM
Pg - 12

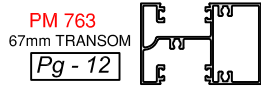

PM 758
67mm SILL
Pg - 12

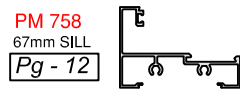

PM 759
67mm BEAD
Pg - 12

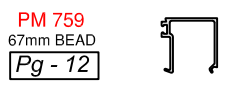

PM 760
67mm TRANSOM
ADAPTOR
Pg - 12

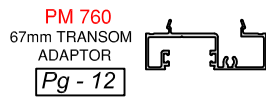

PM 761
67mm FEMALE
MULLION
Pg - 13

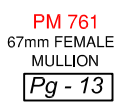

PM 762
67mm MALE
MULLION
Pg - 13

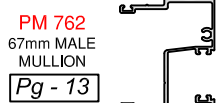

PM 748
67mm JAMB
Pg - 49

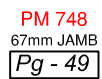

PM 749
67mm REVEAL
JAMB
Pg - 13

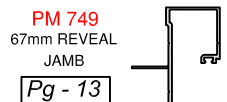

PM 387
67mm CORNER
COUPLER
Pg - 13



PM 395
67mm REVEAL
ADAPTOR
Pg - 12

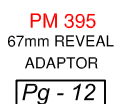

PM 764
67mm POCKET
FILLER
Pg - 12,50

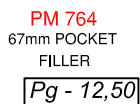

PM 765
67mm AWNING
ADAPTOR
Pg - 12

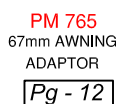

PM 100
18mm POCKET
100mm FRAME
Pg - 14

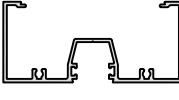

PM 167
100mm LW FRAME
Pg - 14

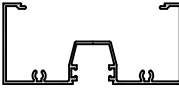

PM 106
100mm NARROW
FRAME
Pg - 15

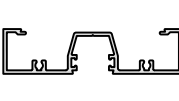

PM 102
100mm SILL
Pg - 14

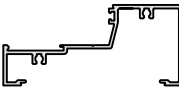

PM 168
100mm LW SILL
Pg - 14

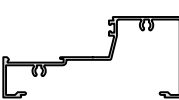

PM 103
100mm BEAD
Pg - 14



PM 110
100mm GLAZING
ADAPTOR
Pg - 14



PM 108
100mm MALE
MULLION
Pg - 16



PM 107
100mm FEMALE
MULLION
Pg - 16



PM 109
100mm HD SELF
MATING MULLION
Pg - 16

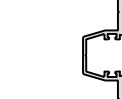

PM 111
100mm PLAIN
FRAME
Pg - 15

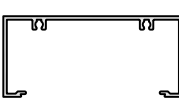

PM 411
100mm PLAIN
25mm FRAME
Pg - 15



PM 112
100mm COC
HEAD
Pg - 16

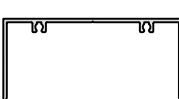

PM 113
100mm COC
COVER
Pg - 16

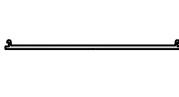

PM 118
100mm CORNER
POST
Pg - 15,62

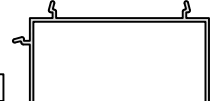

PM 105
100mm FLAT
INFILL
Pgs - 17,21,62,95

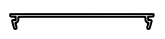

PM 114
100mm FRAME
COUPLER
Pgs - 17,21,52,62



PM 115
100mm REVEAL
ADAPTOR
Pgs - 17,21

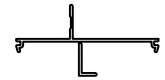

PM 116
18mm POCKET
INFILL
Pgs - 17,21,23,68



PM 117
18mm POCKET
45mm DOOR STOP
Pg - 17



PM 135
18mm POCKET
35mm DOOR STOP
Pg - 17



PM 126
35mm AWNING ADAPTOR
Pg - 31



PM 234
32mm POCKET
100mm FRAME
Pg - 18



PM 235
32mm POCKET
100mm SILL
Pg - 18

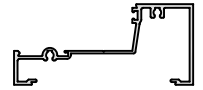

PM 237
32mm POCKET
100mm BEAD
Pg - 18



PM 236
32mm POCKET
100mm GLAZING
ADAPTOR
Pg - 18



PM 238
32mm POCKET
100mm MALE
MULLION
Pg - 19

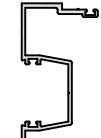

PM 239
32mm POCKET
100mm FEMALE
MULLION
Pg - 19

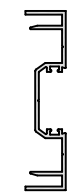

PM 256
32mm POCKET
INFILL
Pg - 19



PM 331
35mm AWNING ADAPTOR
Pg - 17



2005 & 2006 SERIES - 100 & 150mm SG FRAMES

PM 147
18mm POCKET
100 x 45mm FRAME
Pg - 113

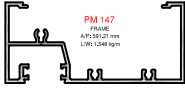

PM 146
18mm POCKET
100 x 45mm TRANSOM
Pg - 113

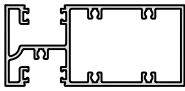

PM 170
18mm POCKET
100 x 45mm TRANSOM
Pg - 113

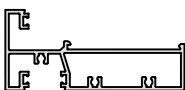

PM 162
18mm POCKET
100 x 45mm SILL
Pg - 113

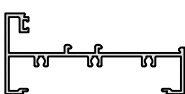

PM 164
18mm POCKET
100 x 45mm BEAD
Pg - 113

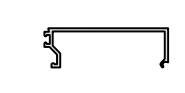

PM 160
18mm POCKET
FEMALE MULLION
Pg - 114

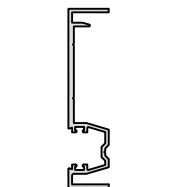

PM 161
18mm POCKET
MALE MULLION
Pg - 114

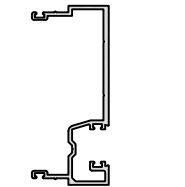

PM 169
18mm POCKET
HD FEMALE MULLION
Pg - 114

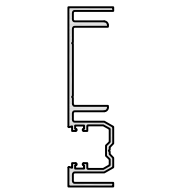

PM 173
18mm POCKET
HD MALE MULLION
Pg - 114

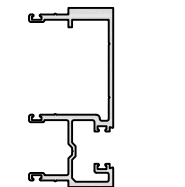

PM 116
18mm POCKET INFILL
Pgs - 17,21,23,68



PM 105
100mm FLAT
INFILL
Pgs - 17,21,62,95



PM 845
18mm POCKET
100 x 50mm FRAME
Pg - 20



PM 846
100mm INT SILL
TRANSOM
Pg - 20

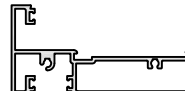

PM 261
100mm SG
BEAD
Pg - 20



PM 847
100mm EXT SILL
TRANSOM
Pg - 20

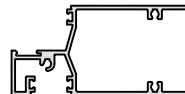

PM 291
EXTERNAL
BEAD
Pgs - 20,22



PM 848
100mm BOX
TRANSOM
Pg - 20

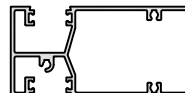

PM 849
18mm POCKET
100mm MALE
MULLION
Pg - 21

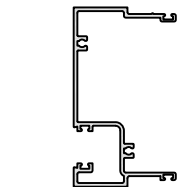

PM 850
18mm POCKET
100mm FEMALE
MULLION
Pg - 21

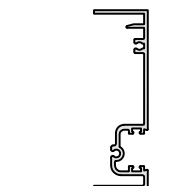

PM 851
18mm POCKET
100mm HD MALE
MULLION
Pg - 21

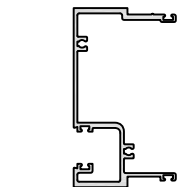

PM 229
18mm POCKET
35mm AWNING
SASH ADAPTOR
Pgs - 21,23

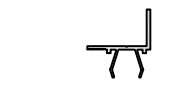

PM 859
18mm POCKET
50mm AWNING
SASH ADAPTOR
Pg - 21,23



PM 721
UNIVERSAL
DOOR STOP INFILL
Pgs - 21,23,28,81,101

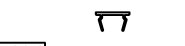

PM 722
UNIVERSAL
DOOR STOP BASE
Pgs - 21,23,28,81,101

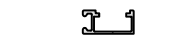

PM 852
18mm POCKET
150 x 50mm FRAME
Pg - 22



PM 853
150mm SILL
TRANSOM
Pg - 22

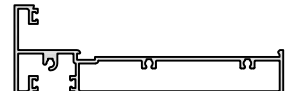

PM 317
150mm SG
BEAD
Pg - 22



PM 854
150mm EXT SILL
TRANSOM
Pg - 22

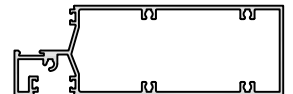

PM 855
150mm BOX
TRANSOM
Pg - 22

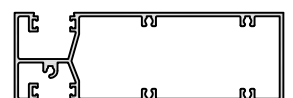

PM 307
150 x 45mm PLAIN
FRAME
Pg - 54



PM 856
18mm POCKET
150mm MALE
MULLION
Pg - 23

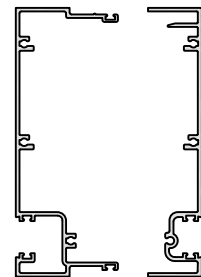

PM 857
18mm POCKET
150mm FEMALE
MULLION
Pg - 23

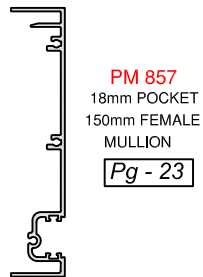

PM 858
18mm POCKET
100mm HD MALE
MULLION
Pg - 23

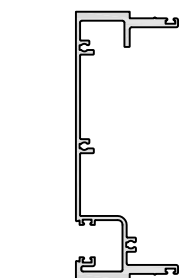

PM 308
150mm FLAT INFILL
Pg - 23



PM 123
CHANNEL BEAD
Pg - 16,34



PM 122
CHANNEL BASE
Pg - 16,34



PM 124
CHANNEL
Pg - 16,34



PM 322
DG CHANNEL BASE
Pg - 16,34



2007 - 2008 ME2 SERIES

**ME2-2000
ME2-50848**
14.5mm POCKET
101.6 x 44.4mm LW FRAME
Pg - 32



ME2-20222
101mm LW FRAME
Pg - 32



ME2-0001
101mm HD FRAME
Pg - 32



ME2-20223
101mm NARROW FRAME
Pg - 32



ME2-20224
101mm SILL
Pg - 33



ME2-20225
101mm BEAD
Pg - 33



ME2-0361
101mm HD SILL
Pg - 33

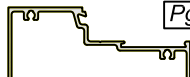

ME2-20240
101mm PLAIN FRAME
Pg - 32

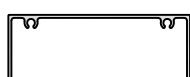

ME2-20226
101mm FLUTED
GLAZING ADAPTOR
Pg - 33



ME2-20227
101mm GLAZING
ADAPTOR
Pg - 33



ME2-20234
101mm SELF
MATING MULLION
Pg - 34

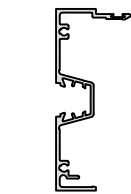

ME2-20235
101mm HD SELF
MATING MULLION
Pg - 34

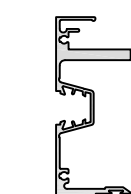

ME2-20237
101mm COC
TRANSOM
Pg - 35



ME2-20238
COC COVER
Pg - 35



**ME2-3652
ME2-51696**
101mm COC
TRANSOM BEAD
Pg - 35



ME2-20228
14.5mm POCKET
101mm CORNER POST
Pg - 34

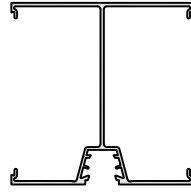

ME2-20229
101mm FLAT FILLER
Pg - 33



PM 710
101mm FLAT FILLER
Pg - 33,38,40



ME2-20239
101mm to 100mm
FRAME COUPLER
Pg - 33,52



ME2-342
101mm REVEAL
ADAPTOR
Pg - 33

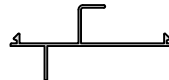

ME2-20230
14.4mm POCKET
FILLER
Pg - 35



ME2-20232
14.4mm POCKET
45mm DOOR STOP
Pg - 35



ME2-20231
14.4mm POCKET
35mm DOOR STOP
Pg - 35



ME2-20233
14.4mm POCKET
35mm SASH STOP
Pg - 35



ME2-0810
32mm POCKET
101.6 x 44.4mm DG FRAME
Pg - 35



ME2-0811
101.6 x 44.4mm DG SILL
Pg - 35



ME2-0813
DG BEAD
Pg - 35



ME2-0812
101.6 x 44.4mm DG ADAPTOR
Pg - 35

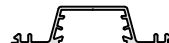

ME2-51289
101.6 x 50mm DG FRAME
Pg - 36

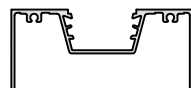

ME2-51290
101.6 x 50mm DG SILL
Pg - 36



ME2-51291
101.6 x 50mm DG BEAD
Pg - 36



ME2-51292
101.6 x 50mm DG ADAPTOR
Pg - 36



ME2-4976
101.6 x 50mm SELF MATING
MULLION
Pg - 36

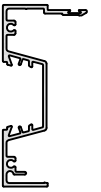

ME2-7886
101.6 x 44.4mm DG POCKET INFILL
Pg - 36



ME2-0707
101.6 x 44.4mm DG 45mm DOOR STOP
Pg - 36



ME2-4679
101.6 x 44.4mm DG 35mm SASH STOP
Pg - 36



ME2-0717
101.6 x 44.4mm DG 50mm SASH STOP
Pg - 36



ME2-52097
32mm POCKET
101.6 x 50mm DG FRAME
Pg - 37

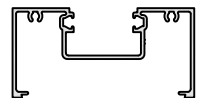

ME2-52098
101.6 x 50mm DG SILL
Pg - 37

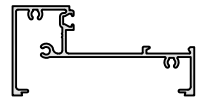

ME2-52099
101.6 x 50mm DG BEAD
Pg - 37



ME2-52100
101.6 x 50mm DG ADAPTOR
Pg - 37

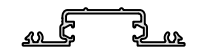

ME2-52101
101.6 x 50mm DG
MALE MULLON
Pg - 37

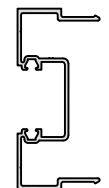

ME2-52102
101.6 x 50mm DG
FEMALE MULLON
Pg - 37

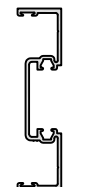

ME2-52103
101.6 x 50mm DG
POCKET FILLER
Pg - 37



ME2-52104
101.6 x 50mm DG
45mm DOOR STOP
Pg - 37



ME2-52105
101.6 x 50mm DG
35mm SASH ADAPTOR
Pg - 37



2009 SERIES

PM 700
103 x 50mm SG
FLUSH GLAZE FRAME
Pg - 38

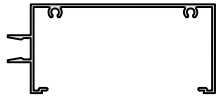

PM 707
FLAT INFILL
Pg - 33,38,40



PM 710
FLAT INFILL
Pg - 33,38,40



PM 787
SG TRANSOM
Pg - 38

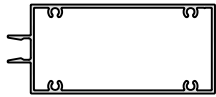

PM 713
SG GLAZED FRAME
Pg - 38



PM 714
SG MALE MULLION
Pg - 39

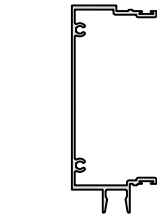

PM 715
SG FEMALE MULLION
Pg - 39

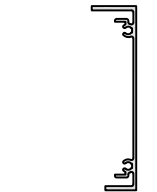

PM 739
103 x 50mm DG
FLUSH GLAZE FRAME
Pg - 40



PM 786
DG TRANSOM
Pg - 40

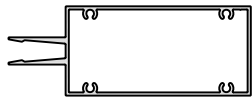

PM 785
DG MALE MULLION
Pg - 41

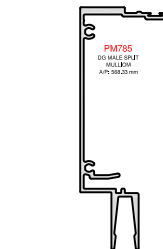

PM 738
DG FEMALE MULLION
Pg - 41

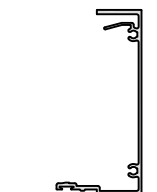

PM 788
STRUCTURAL GLAZED
MALE MULLION
Pg - 41



PM 791
STRUCTURAL GLAZED
MALE MULLION
Pg - 39



PM 792
STRUCTURAL GLAZED
FEMALE MULLION
Pg - 39



PM 709
STD SNAP COVER
Pg - 38, 40



PM 794
DEEP SNAP COVER
Pg - 38



PM 708
RETURN SNAP COVER
Pg - 38



PM 793
DEEP RETURN
SNAP COVER
Pg - 38



PM 795
DG RETURN
SNAP COVER
Pg - 40



PM 712
PLANT ON BASE
Pg - 39



PM 737
DG PLANT ON BASE
Pg - 41



PM 797
DG ADAPTOR
Pg - 38



35mm AWNING SASH

PM 222
OVERLAP SASH
HINGE
Pg - 31, 47



PM 223
SASH HINGE
FRAME
Pg - 31, 47

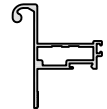

PM 127
SASH FRAME
Pg - 31, 47

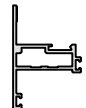

PM 128
DG SASH BEAD
Pg - 27, 29, 31, 47



PM 129
SG SASH BEAD
Pg - 31, 47



PM 126
35mm AWNING ADAPTOR
Pg - 31



PM 229
35mm AWNING ADAPTOR
Pgs - 21,23



PM 765
67mm AWNING
ADAPTOR
Pg - 12



PM 344
WINDER / SCREEN
ADAPTOR
Pgs - 47,97

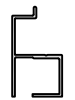

50mm AWNING SASH

PM 840
50mm AWNING
SASH ADAPTOR
Pg - 77

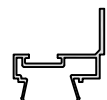

PM 841
50mm AWNING
HINGE RAIL
Pg - 77

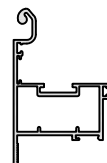

PM 842
50mm AWNING
SASH FRAME
Pg - 48, 77

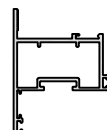

PM 843
SASH DG BEAD
Pg - 48, 77



PM 844
SASH SG BEAD
Pg - 48, 77



PM 839
WINDER ADAPTOR
Pg - 47, 77

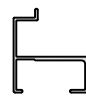

PM 838
35mm SASH ADAPTOR
Pg - 77



COMMERCIAL SHOPFRONT DOORS

PM 185
65mm HINGE STILE
Pg - 24

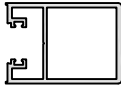

PM 346
70mm BEVELLED LW HINGE STILE
Pg - 24



PM 184
70mm BEVELLED HINGE STILE
Pg - 24,69

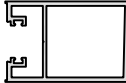

PM 347 - PM196
65mm SLIDING DOOR STILE
Pg - 25

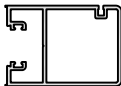

PM 186
65mm LOCK STILE
Pg - 24

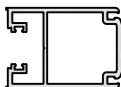

PM 345
70mm LW LOCK STILE
Pg - 24,69

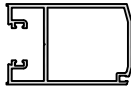

PM 183
70mm LOCK STILE
Pg - 24,69

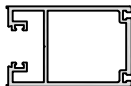

PM 342
70mm MEETING STILE
Pg - 25



PM 198
120mm WIDE LOCK STILE
Pg - 25



PM 197
120mm WIDE HINGE STILE
Pg - 25



PM 348
83mm LW DOOR RAIL
Pg - 26,70

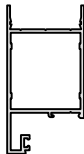

PM 189
85mm DOOR RAIL
Pg - 26

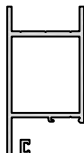

PM 349
115mm LW DOOR RAIL
Pg - 26,70

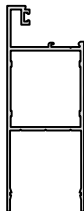

PM 187
120mm DOOR RAIL
Pg - 26

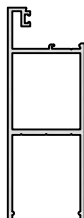

PM 193
45mm DOOR MIDRAIL
Pg - 27,70



PM 188
DOOR RAIL BEAD
Pg - 26,70



PM 350
MIDRAIL ADAPTOR
Pg - 27,70



PM 351
SEAL ADAPTOR
Pg - 27



PM 134
DG ADAPTOR
Pg - 27



PM 128
BEAD
Pg - 27, 29, 31, 47, 80



PM 824
77mm DG LOCK STILE
Pg - 28,71,80

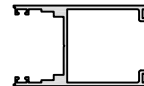

PM 825
77mm DG HINGE STILE
Pg - 28,71,80

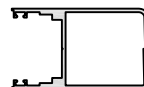

PM 822
77mm DG SLIDER STILE
Pg - 28,80

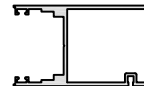

PM 823
85mm DG TOP RAIL
Pg - 29,72,80

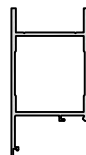

PM 827
115mm DG RAIL
Pg - 29,72,80

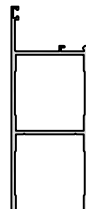

PM 826
75mm DG MIDRAIL
Pg - 29,72,80

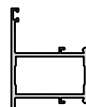

PM 837
115mm DG MIDRAIL
Pg - 29,72,81

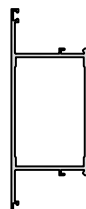

PM 828
DG to SG DOOR STILE
ADAPTOR
Pg - 28,71,80



PM 836
DG to SG DOOR STILE
BEAD
Pg - 29,72,80



PM 200
OVERHEAD SLIDING
DOOR TRACK
Pg - 27

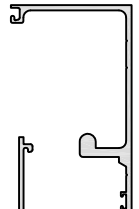

PM 201
PELMET
Pg - 27



PM 203
BOTTOM GUIDE
Pg - 27



PM 323
SLIDING DOOR RECEIVER
Pg - 27



PM 324
RECEIVER INFILL
Pg - 27



PM 721
UNIVERSAL
DOOR STOP INFILL
Pgs - 21,23,28,81,101



PM 722
UNIVERSAL
DOOR STOP BASE
Pgs - 21,23,28,81,101



PM 191
PLANT ON
DOOR STOP
Pgs - 23,28,42



PM 120
STD THRESHOLD
Pg - 30,80,101

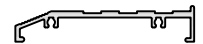

PM 119
SLOPED THRESHOLD
Pg - 30,81

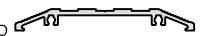

PM 121
OPEN OUT THRESHOLD
Pg - 30,81

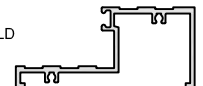

PM 298
150MM RAMPED THRESHOLD
Pg - 30,81,101



PM 858
150MM RAMPED THRESHOLD
Pg - 30,81,101



ME2 - COMMERCIAL SHOPFRONT DOORS

7000 SERIES BI-FOLD DOORS

ME2-3646
62mm HINGE STILE
Pg - 42

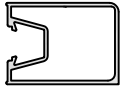

ME2-3648
62mm LOCK STILE
Pg - 42

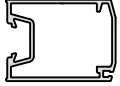

ME2-0263
71mm PIVOT STILE
Pg - 42



ME2-51294
71mm LOCK STILE
Pg - 42



ME2-51295
71mm HINGE STILE
Pg - 42



ME2-51697
71mm SLIDER STILE
Pg - 42



ME2-51726
71mm MEETING STILE
Pg - 42

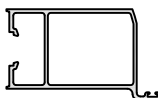

ME2-51693
113mm LOCK STILE
Pg - 43



ME2-0269
113mm PIVOT STILE
Pg - 43



ME2-51692
113mm HINGE STILE
Pg - 43

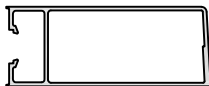

ME2-51691
113mm SLIDER STILE
Pg - 43

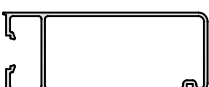

ME2-51694
83mm LW DOOR RAIL
Pg - 44



ME2-3651
83mm DOOR RAIL
Pg - 44



ME2-3654
115mm DOOR RAIL
Pg - 44

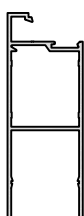

ME2-51293
ME2-52513
111mm DOOR RAIL
Pg - 44

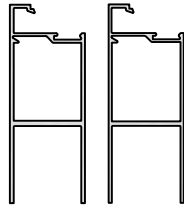

ME2-0012
45mm MIDRAIL
Pg - 43



ME2-0413
123mm MIDRAIL
Pg - 43



ME2-3652
LW RAIL BEAD
Pg - 44



ME2-51696
RAIL BEAD
Pg - 44



ME2-07820
71mm DG LOCK STILE
Pg - 45

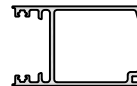

ME2-07821
71mm DG HINGE STILE
Pg - 45

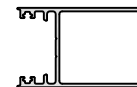

ME2-07819
71mm DG SLIDER STILE
Pg - 45

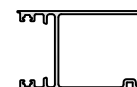

ME2-5150
WIDE DG PIVOT STILE
Pg - 46



ME2-5151
WIDE DG HINGE STILE
Pg - 46

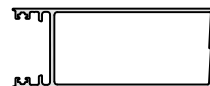

ME2-5170
WIDE DG SLIDER STILE
Pg - 46



ME2-5171
WIDE DG LOCK STILE
Pg - 46

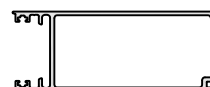

ME2-0931
89mm DG RAIL
Pg - 45

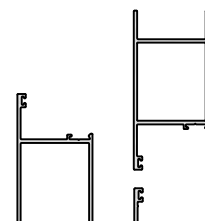

ME2-0933
100mm DG MID RAIL
Pg - 45

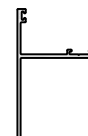

ME2-07822
116mm DG RAIL
Pg - 45

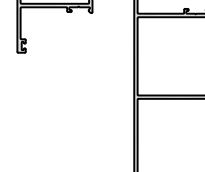

ME2-07823
DG DOOR BEAD
Pg - 45



ME2-07824
MEETING STILE ADAPTOR
Pg - 42



PM 206
BI-FOLD HEAD TRACK
Pg - 67

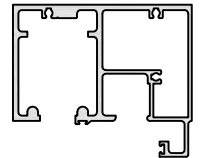

BRIO 180
SINGLE HEAD TRACK
Pg - 68

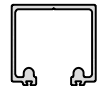

PM 209
BI-FOLD DOOR STOP
SILL TRACK
Pg - 67



PM 211
BI-FOLD DOOR FLAT
SILL TRACK
Pg - 67



PM 213
POLYPROPYLENE
CHANNEL INFILL
Pg - 67



PM 214
FLOOR CHANNEL
Pg - 67



PM 225
BI-FOLD
PLAIN JAMB
Pg - 68

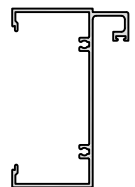

PM 210
BI-FOLD
JAMB / MULLION
Pg - 68

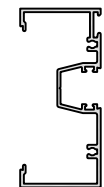

PM 220
BI-FOLD JAMB
STOP
Pg - 68



PM 218
BI-FOLD HD
STILE
Pg - 69



PM 219
BI-FOLD HD
PLAIN STILE
Pg - 69



3001 - 3002 SERIES SLIDING WINDOWS

PM 750
67mm HEAD TRACK

Pg - 49

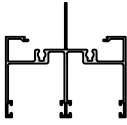

PM 751
67mm SILL TRACK

Pg - 49

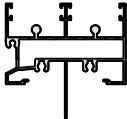

PM 335
67mm SILL TRANSOM

Pg - 49

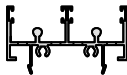

PM 748
67mm SILL TRANSOM
ADAPTOR

Pg - 49



PM 760
67mm HEAD TRANSOM
ADAPTOR

Pg - 49

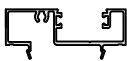

PM 752
67mm JAMB

Pg - 49

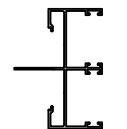

PM 753
67mm JAMB
ADAPTOR

Pg - 49

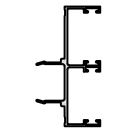

PM 341
67mm TRANSOM
STIFFENER

Pg - 50

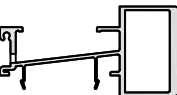

PM 755
TOP SCREEN
ADAPTOR

Pg - 50



PM 439
BOTTOM SCREEN
ADAPTOR

Pg - 50



PM 438
SCREEN
ADAPTOR

Pg - 50



FLE0952
SCREEN
FRAME

Pg - 45



FLE0952
SLY SCREEN FRAME
APR 85,80mm
LW15,300mm

3003 - 3004 - 3005 - 3006 SERIES SLIDING WINDOWS & DOORS

PM 401
100mm HEAD TRACK

Pg - 51

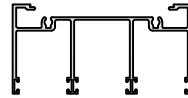

PM 417
100mm TRANSOM

Pg - 52

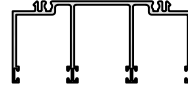

PM 264
100mm WHEELCHAIR
SILL TRACK

Pg - 52

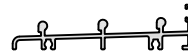

PM 406
100mm SILL TRACK

Pg - 51

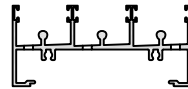

PM 432
100mm SUMP SILL TRACK

Pg - 52

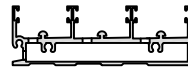

PM 400
100mm HIGH RISE
SILL TRACK

Pg - 52

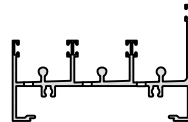

PM 280
100mm WINDOW
SILL TRANSOM

Pg - 52

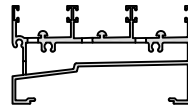

PM 412
100 x 30mm
JAMB

Pg - 51

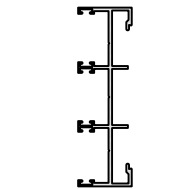

PM 398
100 x 45mm
JAMB

Pg - 51

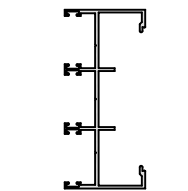

PM 399
100 x 45mm
JAMB

Pg - 51

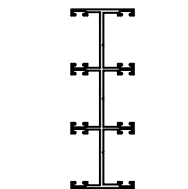

PM 436
150mm HEAD TRACK

Pg - 53

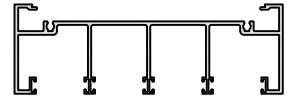

PM 428
150mm SILL TRACK

Pg - 53

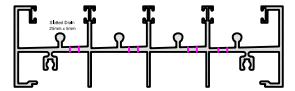

PM 437
150mm JAMB

Pg - 54

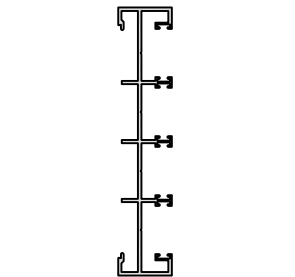

PM 372
164mm HEAD TRACK

Pg - 55

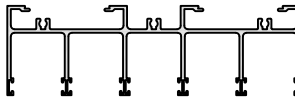

PM 376
164mm SILL TRACK

Pg - 55

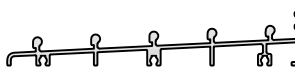

PM 373
164mm SILL TRACK

Pg - 55

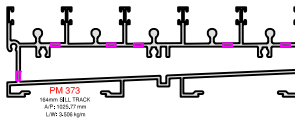

PM 373
164mm SILL TRACK
APR 152,7mm
LW15,300mm

PM 371
164mm JAMB

Pg - 56

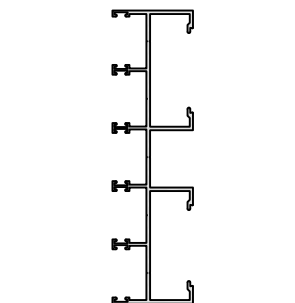

PM 375
164mm PLAIN
JAMB

Pg - 56

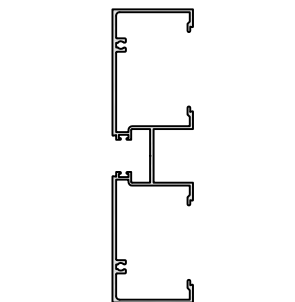

3001 - 3002 SERIES SLIDING WINDOWS

3003 - 3004 - 3005 - 3006 SERIES SLIDING WINDOWS & DOORS

PM 750
67mm HEAD TRACK

Pg - 49

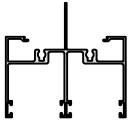

PM 751
67mm SILL TRACK

Pg - 49

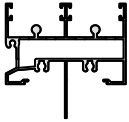

PM 335
67mm SILL TRANSOM

Pg - 49

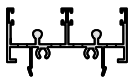

PM 748
67mm SILL TRANSOM
ADAPTOR

Pg - 49



PM 760
67mm HEAD TRANSOM
ADAPTOR

Pg - 49

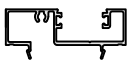

PM 752
67mm JAMB

Pg - 49

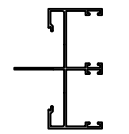

PM 753
67mm JAMB
ADAPTOR

Pg - 49

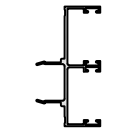

PM 341
67mm TRANSOM
STIFFENER

Pg - 50

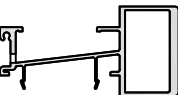

PM 755
TOP SCREEN
ADAPTOR

Pg - 50



PM 439
BOTTOM SCREEN
ADAPTOR

Pg - 50



PM 439
SCREEN
ADAPTOR

Pg - 50

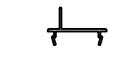

FLE0952
SCREEN
FRAME

Pg - 45



FLE0952
FLEXIBLE SCREEN FRAME
APR 85,50mm
LW15,50mm

PM 401
100mm HEAD TRACK

Pg - 51

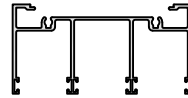

PM 417
100mm TRANSOM

Pg - 52

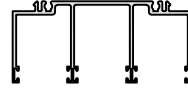

PM 264
100mm WHEELCHAIR
SILL TRACK

Pg - 52

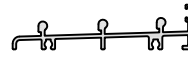

PM 406
100mm SILL TRACK

Pg - 51

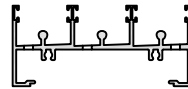

PM 432
100mm SUMP SILL TRACK

Pg - 52

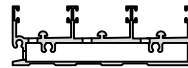

PM 400
100mm HIGH RISE
SILL TRACK

Pg - 52

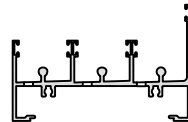

PM 280
100mm WINDOW
SILL TRANSOM

Pg - 52

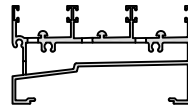

PM 412
100 x 30mm
JAMB

Pg - 51

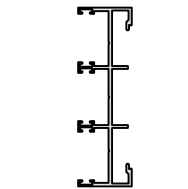

PM 398
100 x 45mm
JAMB

Pg - 51

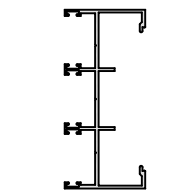

PM 399
100 x 45mm
JAMB

Pg - 51

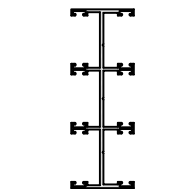

PM 436
150mm HEAD TRACK

Pg - 53

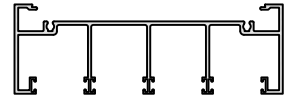

PM 428
150mm SILL TRACK

Pg - 53

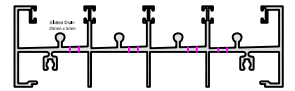

PM 437
150mm JAMB

Pg - 54

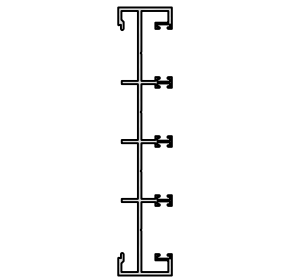

PM 372
164mm HEAD TRACK

Pg - 55

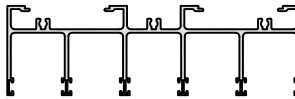

PM 376
164mm SILL TRACK

Pg - 55

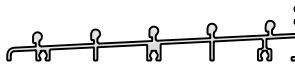

PM 373
164mm SILL TRACK

Pg - 55

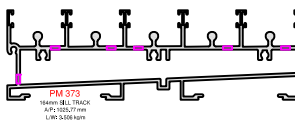

PM 373
164mm SILL TRACK
APR 150,7mm
LW15,50mm

PM 371
164mm JAMB

Pg - 56

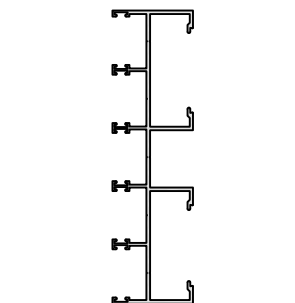

PM 375
164mm PLAIN
JAMB

Pg - 56

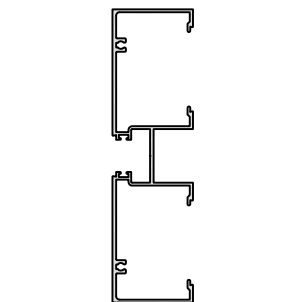

3000 SERIES SLIDING WINDOWS & DOORS

PM 767
DG STANDARD
INTERLOCK STILE
Pg - 57



PM 789
DG DOUBLE
INTERLOCK STILE
Pg - 57



PM 768
DG 33mm
INTERLOCK STILE
Pg - 57

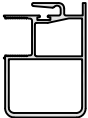

PM 776
DG 66mm
INTERLOCK STILE
Pg - 57

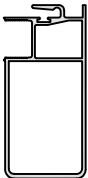

PM 770
DG 21mm STILE
Pg - 57



PM 771
DG PLAIN
LOCK STILE
Pg - 57



PM 769
DG MALE
MEETING STILE
Pg - 57a



PM 766
DG 33mm MALE
MEETING STILE
Pg - 57a

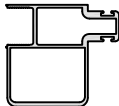

PM 772
DG FEMALE
MEETING STILE
Pg - 57a



PM 773
DG 33mm FEMALE
MEETING STILE
Pg - 57a

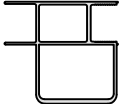

PM 777
DG 66mm MALE
MEETING STILE
Pg - 57a

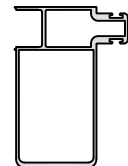

PM 778
DG 66mm FEMALE
MEETING STILE
Pg - 57a

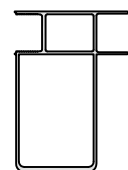

PM 775
DG 25mm
TOP RAIL
Pg - 57



PM 774
DG 56mm
RAIL
Pg - 57



PM 414
SG STANDARD
INTERLOCK STILE
Pg - 58



PM 409
SG DOUBLE
INTERLOCK STILE
Pg - 58



PM 421
SG 33mm
INTERLOCK STILE
Pg - 58

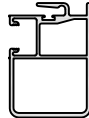

PM 424
SG 66mm
INTERLOCK STILE
Pg - 58

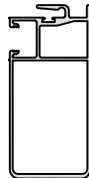

PM 427
SG 86mm
INTERLOCK STILE
Pg - 59



PM 410
SG 21mm STILE
Pg - 58



PM 413
SG HANDLE
LOCK STILE
Pg - 58

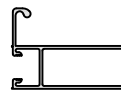

PM 415
SG PLAIN
LOCK STILE
Pg - 58

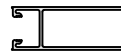

PM 420
SG 33mm
LOCK STILE
Pg - 58

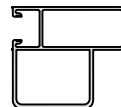

PM 434
SG MALE
MEETING STILE
Pg - 58



PM 418
SG 33mm MALE
MEETING STILE
Pg - 58

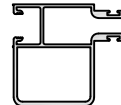

PM 422
SG 66mm MALE
MEETING STILE
Pg - 59

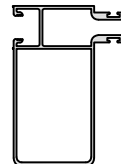

PM 425
SG 86mm MALE
MEETING STILE
Pg - 59

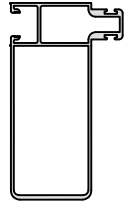

PM 396
SG FEMALE
MEETING STILE
Pg - 58



PM 419
SG 33mm FEMALE
MEETING STILE
Pg - 58

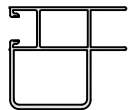

PM 423
SG 66mm FEMALE
MEETING STILE
Pg - 59

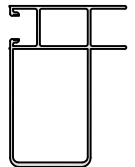

PM 426
SG 86mm FEMALE
MEETING STILE
Pg - 59

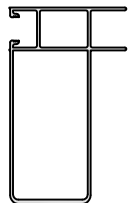

PM 397
SG 33mm FEMALE
90 Deg CORNER STILE
Pg - 59

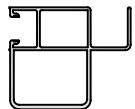

PM 407
SG 25mm
TOP RAIL
Pg - 58



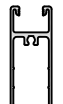

PM 369
SG 56mm
RAIL
Pg - 58





3000 SERIES ADAPTORS

- PM 404**
JAMB ADAPTOR
Pg - 54,60



- PM 405**
PLAIN TRACK INFILL
Pg - 60



- PM 416**
TREAD THRESHOLD
Pg - 60



- PM 440**
RAMPED THRESHOLD
Pg - 60



- PM 449**
RAMPED THRESHOLD
Pg - 60

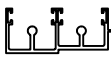

- PM 447**
SINGLE TRACK
SCREEN ADAPTOR
Pg - 60



- PM 448**
SCREEN TRACK
SUPPORT
Pg - 60

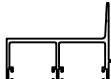

- PM 446**
DOUBLE TRACK
SCREEN ADAPTOR
Pg - 60



- PM 445**
SINGLE TRACK
SCREEN ADAPTOR
Pg - 60,83

- PM 444**
DOUBLE TRACK
SCREEN ADAPTOR
Pg - 60

- PM 740**
SCREEN DOOR
CHANNEL
Pg - 60,92



- PM 487**
18mm GLAZING
ADAPTOR
Pg - 60



- PM 488**
12mm GLAZING
ADAPTOR
Pg - 60

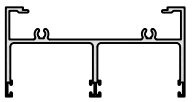

8000 SERIES SLIDING WINDOWS & DOORS

- PM 670**
100mm HEAD
Pg - 83

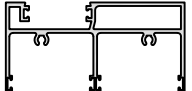

- PM 681**
100mm TRANSOM
Pg - 83

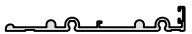

- PM 820**
100mm WHEELCHAIR
SILL THRESHOLD
Pg - 83

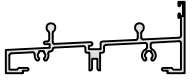

- PM 819**
100mm WHEELCHAIR SILL
Pg - 83

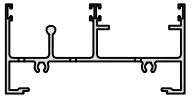

- PM 674**
100mm LOW PROFILE SILL
Pg - 82

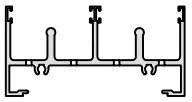

- PM 675**
100mm LOW PROFILE SILL
SCREEN ADAPTOR
Pg - 83

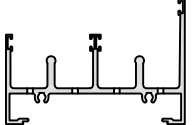

- PM 666**
100mm LW STANDARD SILL
Pg - 82

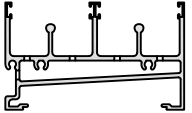

- PM 671**
100mm HD STANDARD SILL
Pg - 82



- PM 673**
100mm HIGH PERFORMANCE
SILL
Pg - 82

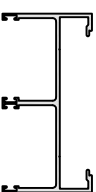

- PM 656**
100mm SUMP SILL
TRANSOM
Pg - 83

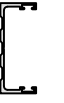

- PM 257**
100mm LOW LITE
ADAPTOR
Pg - 82



- PM 672**
100mm JAMB
Pg - 83

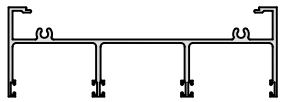

- PM 655**
PLANT ON JAMB ADAPTOR
Pg - 92

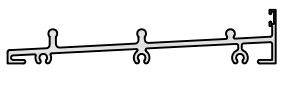

- PM 658**
SNAP IN JAMB ADAPTOR
Pg - 92

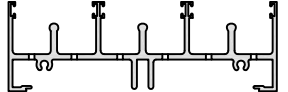

- PM 676**
150mm HEAD / JAMB
Pg - 84

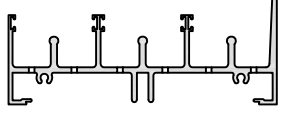

- PM 680**
150mm LOW PROFILE
SILL
Pg - 84

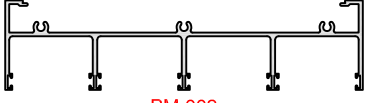

- PM 678**
150mm STANDARD
SILL
Pg - 84

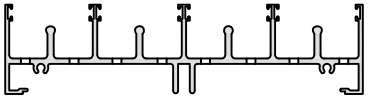

- PM 679**
150mm HIGH
PERFORMANCE SILL
Pg - 84



- PM 662**
200mm HEAD / JAMB
Pg - 85



- PM 663**
200mm SILL
Pg - 85

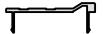

- PM 682**
PLAIN TRACK INFILL
Pg - 92,107



- PM 685**
FLAT THRESHOLD
Pg - 92,107



- PM 657**
LIPPED THRESHOLD
Pg - 92,107



- PM 683**
HIGH THRESHOLD
Pg - 92,107



- PM 684**
RAISED THRESHOLD
Pg - 92

- PM 742**
7mm PLANT ON INTERLOCK
Pg - 92,107

- PM 743**
SCREEN DOOR ADAPTOR
Pg - 92,107

- PM 741**
SCREEN DOOR TRACK
Pg - 92,107

- PM 744**
WINDOW SCREEN ADAPTOR
Pg - 92,107



8000 SERIES SLIDING WINDOWS & DOORS

PM 800
DG NARROW STILE
Pg - 86



PM 801
DG DEEP NARROW STILE
Pg - 86

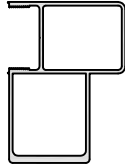

PM 802
DG NARROW INTERLOCK STILE
Pg - 86

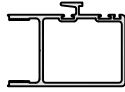

PM 803
DG DEEP NARROW INTERLOCK STILE
Pg - 86

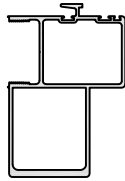

PM 804
DG NARROW FEMALE MEETING STILE
Pg - 87

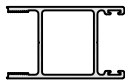

PM 805
DG NARROW MALE MEETING STILE
Pg - 87

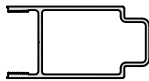

PM 806
DG DEEP NARROW FEMALE MEETING STILE
Pg - 87

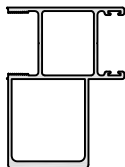

PM 808
DG NARROW MALE MEETING STILE
Pg - 87

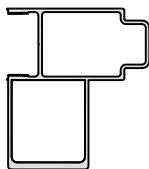

PM 807
DG RAIL
Pg - 86

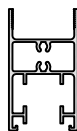

PM 812
SG NARROW STILE
Pg - 88

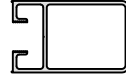

PM 811
SG DEEP NARROW STILE
Pg - 88

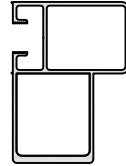

PM 810
SG NARROW INTERLOCK STILE
Pg - 88

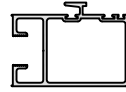

PM 813
SG DEEP NARROW INTERLOCK STILE
Pg - 88

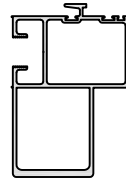

PM 814
SG NARROW FEMALE MEETING STILE
Pg - 89

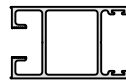

PM 815
SG NARROW MALE MEETING STILE
Pg - 89

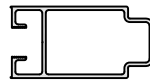

PM 816
SG DEEP NARROW FEMALE MEETING STILE
Pg - 89

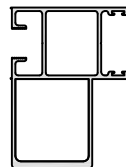

PM 818
SG NARROW MALE MEETING STILE
Pg - 89

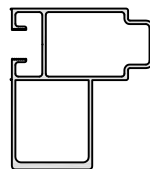

PM 817
SG RAIL
Pg - 88

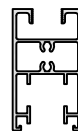

PM 686
DG WIDE STILE
Pg - 90



PM 688
SG DEEP WIDE STILE
Pg - 90

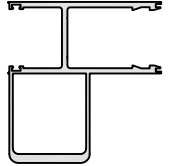

PM 687
SG WIDE INTERLOCK STILE
Pg - 90

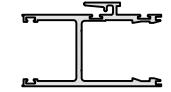

PM 689
SG DEEP WIDE INTERLOCK STILE
Pg - 90

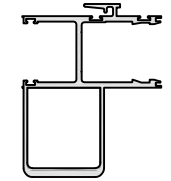

PM 691
DG BEAD
Pg - 90

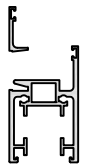

PM 690
DG RAIL
Pg - 90



PM 727
SG WIDE STILE
Pg - 91

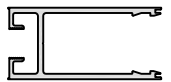

PM 728
SG DEEP WIDE STILE
Pg - 91

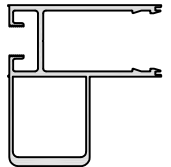

PM 725
SG WIDE INTERLOCK STILE
Pg - 91

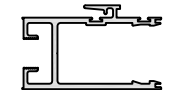

PM 726
SG DEEP WIDE INTERLOCK STILE
Pg - 91

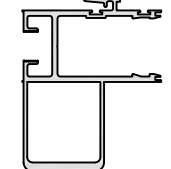

PM 692
STILE INLAY
Pg - 91



PM 695
INTERLOCK STILE INLAY
Pg - 91



PM 694
FEMALE MEETING STILE INLAY
Pg - 91



PM 693
MALE MEETING STILE INLAY
Pg - 91



9000 PATH SERIES THERMAL BREAK

PATH 100
100mm FRAME
Pg - 93

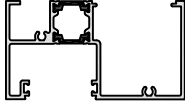

PATH 101
100mm BOX TRANSOM
Pg - 93

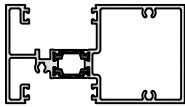

PATH 102
100mm SILL TRANSOM
Pg - 93

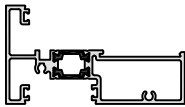

PATH 103
100mm SILL BEAD
Pg - 93

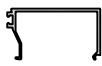

PATH 104
100mm EXT
SILL / TRANSOM
Pg - 94

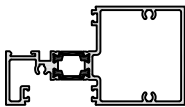

PATH 105
EXTERNAL BEAD
Pg - 94



PATH 106
100mm MALE
MULLION
Pg - 94

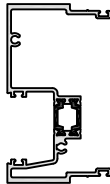

PATH 107
100mm FEMALE
MULLION
Pg - 94



PATH 177
100mm FRAME
INFILL
Pg - 93



PATH 143
POCKET FILLER
Pg - 94



PATH 126
150mm FRAME
Pg - 95

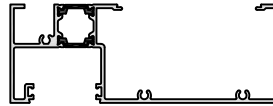

PATH 127
120mm BOX TRANSOM
Pg - 95

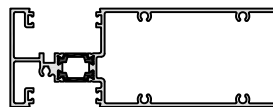

PATH 129
100mm SILL TRANSOM
Pg - 95

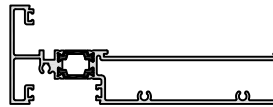

PATH 128
150mm SILL BEAD
Pg - 95



PATH 135
150mm EXT
SILL / TRANSOM
Pg - 96

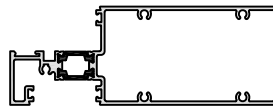

PATH 105
EXTERNAL BEAD
Pg - 96



PATH 133
150mm MALE
MULLION
Pg - 96

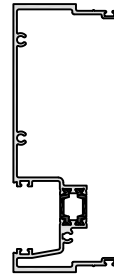

PATH 134
150mm FEMALE
MULLION
Pg - 96

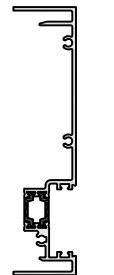

PM 105
150mm FRAME
INFILL
Pg - 95



PATH 110
100mm 50mm TH AWNING
HEAD / TRANSOM
Pg - 98

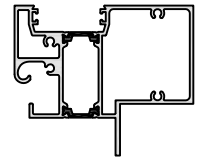

PATH 111
100mm 50mm TH AWNING
TRANSOM
Pg - 98

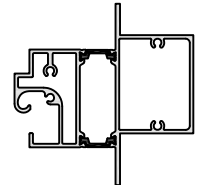

PATH 112
100mm 50mm TH AWNING
SILL / TRANSOM
Pg - 98

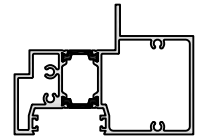

PATH 130
150mm 50mm TH AWNING
HEAD / TRANSOM
Pg - 99

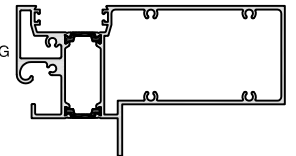

PATH 131
150mm 50mm TH AWNING
TRANSOM
Pg - 99

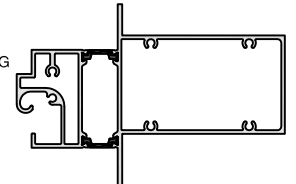

PATH 132
150mm 50mm TH AWNING
SILL / TRANSOM
Pg - 99

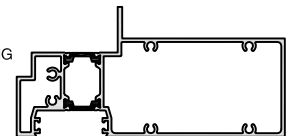

PATH 121
50mm AWNING
SASH ADAPTOR
Pg - 97

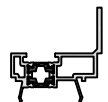

PATH 122
50mm AWNING
HINGE RAIL
Pg - 97

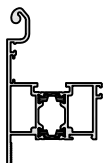

PATH 123
50mm AWNING
SASH FRAME
Pg - 00

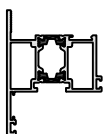

PM 843
SASH BEAD
Pg - 97



PM 839
WINDER ADAPTOR
Pg - 97



9000 PATH SERIES THERMAL BREAK

PATH 181
110mm DOOR
LOCK STILE
Pg - 100

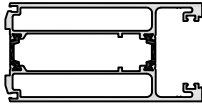

PATH 185
110mm DOOR
HINGE STILE
Pg - 100

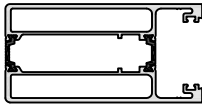

PATH 182
120mm DOOR
RAIL
Pg - 100

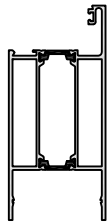

PATH 180
RAIL BEAD
Pg - 100



PATH 183
85mm DOOR
MID RAIL
Pg - 101

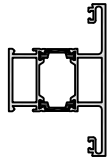

PM 721
UNIVERSAL
DOOR STOP INFILL
Pgs - 21,23,28,81,101



PM 722
UNIVERSAL
DOOR STOP BASE
Pgs - 21,23,28,81,101



PM 120
STD THRESHOLD
Pg - 30,80,101

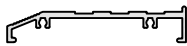

PM 119
SLOPED THRESHOLD
Pg - 30,81

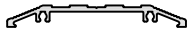

PM 298
150MM RAMPED THRESHOLD
Pg - 30,81,101



PATH 164
100mm - S DOOR
HEAD / TRANSOM
Pg - 103

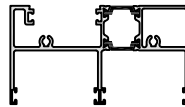

PATH 162
100mm - S DOOR
LOW RISE SILL
Pg - 102

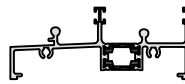

PM 675
100mm LOW RISE SILL
SCREEN ADAPTOR
Pg - 107



PATH 161
100mm - S DOOR
STANDARD SILL
Pg - 102

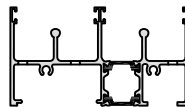

PATH 159
100mm - S DOOR
HIGH RISE SILL
Pg - 102

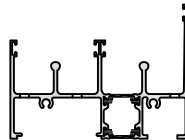

PATH 160
100mm - S WINDOW
SILL / TRANSOM
Pg - 103

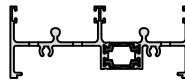

PATH 163
100mm - S WINDOW
TRANSOM ADAPTOR
Pg - 103

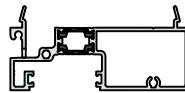

PATH 165
100mm - S DOOR
WINDOW JAMB
Pg - 103

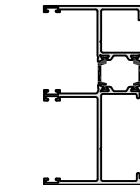

PATH 168
150mm - S DOOR
HEAD
Pg - 104

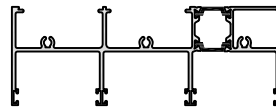

PATH 169
150mm - S DOOR
STANDARD SILL
Pg - 104

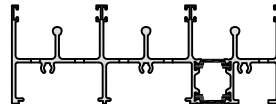

PATH 171
150mm - S DOOR
HIGH RISE SILL
Pg - 104

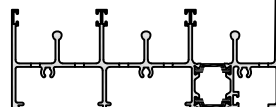

PATH 170
150mm - S DOOR
JAMB
Pg - 105

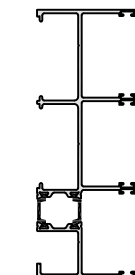

PATH 158
SD TRACK
INFILL
Pg - 107



PATH 149
SLIDING DOOR
PLAIN STILE
Pg - 105

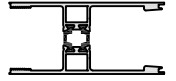

PATH 150
SLIDING DOOR
HD STILE
Pg - 105

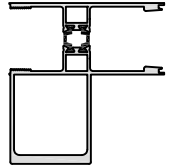

PATH 154
SLIDING DOOR
PLAIN INTERLOCK STILE
Pg - 106

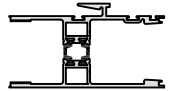

PATH 155
SLIDING DOOR
HD INTERLOCK STILE
Pg - 106

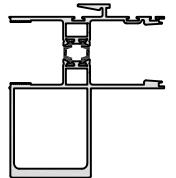

PATH 156
SLIDING DOOR
RAIL
Pg - 107

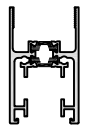

PATH 151
SLIDING DOOR
PLAIN STILE INLAY
Pg - 106



PATH 152
SLIDING DOOR
FEMALE STILE INLAY
Pg - 106



PATH 153
SLIDING DOOR
MALE STILE INLAY
Pg - 106



PATH 166
SLIDING DOOR
JAMB ADAPTOR
Pg - 106

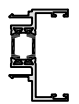

PM 655
SLIDING DOOR
JAMB ADAPTOR
Pg - 106



PATH 177
100mm FRAME
INFILL
Pg - 93



PM 682
PLAIN TRACK INFILL
Pg - 107



PM 685
FLAT THRESHOLD
Pg - 107



PM 657
LIPPED THRESHOLD
Pg - 107

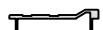

PM 683
HIGH THRESHOLD
Pg - 107



**6000 SERIES
FIXED & ADJUSTABLE LOUVRES**

PM 622
80mm LOUVRE
Pg - 61a



LVR 51532
85mm LOUVRE
Pg - 61a



LVR 3213
90mm LOUVRE
Pg - 61a

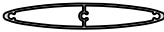

LVR 50837
100mm LOUVRE
Pg - 61a



LVR 3214
115mm LOUVRE
Pg - 61a



LVR 20031
150mm LOUVRE
Pg - 61a



LVR 4220
48mm LOUVRE
Pg - 61

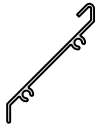

LVR 8376
65mm LOUVRE
Pg - 61

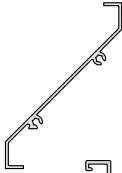

LVR 8377
65mm LOUVRE BRACKET
Pg - 61



LVR 3114
88mm LOUVRE
Pg - 61

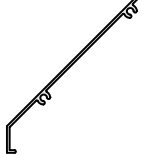

PM 411
100mm PLAIN
25mm FRAME
Pg - 15,62



PM 111
100mm PLAIN
FRAME
Pg - 15,62



CH325832
CHANNEL
Pg - 61



CR 8041
48mm LOUVRE
FRAME
Pg - 62



LVR 4021
88mm LOUVRE
FRAME
Pg - 62

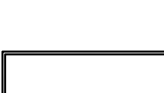

PM 618
43mm RIGHT HAND
SLOTTED RAIL
Pg - 63

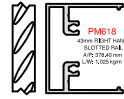

PM 619
43mm LEFT HAND
SLOTTED RAIL
Pg - 63

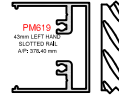

PM 620
43mm TOP / BOTTOM
RAIL
Pg - 63



PM 621
43mm PUNCHED
RAIL
Pg - 63

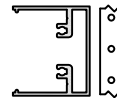

PM 614
WIDE LEFT HAND
SLOTTED RAIL
Pg - 64

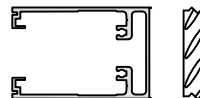

PM 615
WIDE RIGHT HAND
SLOTTED RAIL
Pg - 64

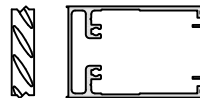

PM 616
WIDE PUNCHED
RAIL
Pg - 64

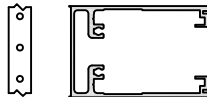

PM 630
100mm TOP / BOTTOM
RAIL
Pg - 63

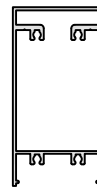

PM 635
100mm SLIDER
RAIL
Pg - 64

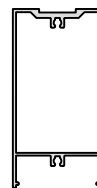

PM 623
FLAT INFILL
Pg - 63



PM 624
ADJUSTABLE
LOUVRE INFILL
Pg - 63



PM 631
WEATHER PILE
INFILL
Pg - 63



PM 637
FIXED LOUVRE
INFILL
Pg - 63



PM 612
WIDE STILE
INFILL
Pg - 64



PM 628
HEAD / JAMB
FIXING CHANNEL
Pg - 63



PM 629
MULLION
JOINER
Pg - 63

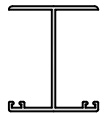

BRIO 120
TOP TRACK
Pg - 65



BRIO 180
TOP TRACK
Pg - 65,68

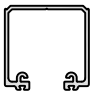

PM 214
BOTTOM CHANNEL
Pg - 65,67



PM 213
BOTTOM CHANNEL INSERT
Pg - 65,67



PM 247
TOP TRACK
Pg - 65

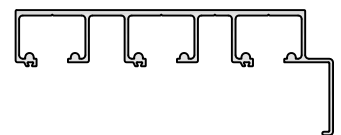

PM 249
BOTTOM TRACK
Pg - 65



PM 248
SUB SILL
Pg - 65



64mm STUD PARTITION

PAR 100
100mm FRAME
Pg - 108



PAR 101
100mm SILL
Pg - 108

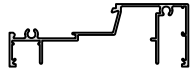

PAR 102
100mm SILL BEAD
Pg - 108



PAR 103
GLAZING ADAPTOR
Pg - 108



PAR 104
CEILING CHANNEL
Pg - 108



PAR 105
100mm FRAME WITH LEG
Pg - 109

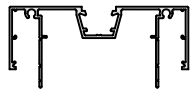

PAR 106
45mm DOOR STOP
Pg - 109



PAR 107
35mm DOOR STOP
Pg - 109



PAR 108
POCKET INFILL
Pg - 109,111



PAR 109
100mm FLAT INFILL
Pg - 109



PAR 110
100mm CHANNEL
Pg - 109



92mm STUD PARTITION

PAR 200
131mm FRAME
Pg - 110



PAR 201
131mm SILL
Pg - 110



PAR 202
131mm SILL BEAD
Pg - 110



PAR 203
GLAZING ADAPTOR
Pg - 110



PAR 204
CEILING CHANNEL
Pg - 110



PAR 205
131mm FRAME WITH LEG
Pg - 111



PAR 206
45mm DOOR STOP
Pg - 111



PAR 207
38mm DOOR STOP
Pg - 111



PAR 208
35mm DOOR STOP
Pg - 111



PAR 209
131mm FLAT INFILL
Pg - 111



PAR 210
131mm CHANNEL
Pg - 111



GLAZING WEDGES CHANNELS & COMPONENTS

CAPTIVE & ROLL IN GLAZING WEDGES: **Pg-115, 116**

SLIDING WINDOW & DOOR GLAZING CHANNELS: **Pg-117**

COMPONENTS: **Pg-118, 119**

GEOMETRIC

ANGLES: **Pg-120,121**

FLAT BARS: **Pg-122**

CHANNELS: **Pg-123**

SQUARE & RECTANGLE BOX: **Pg-124,125,126,127**

TUBES: **Pg-128**

SCALE 1:1

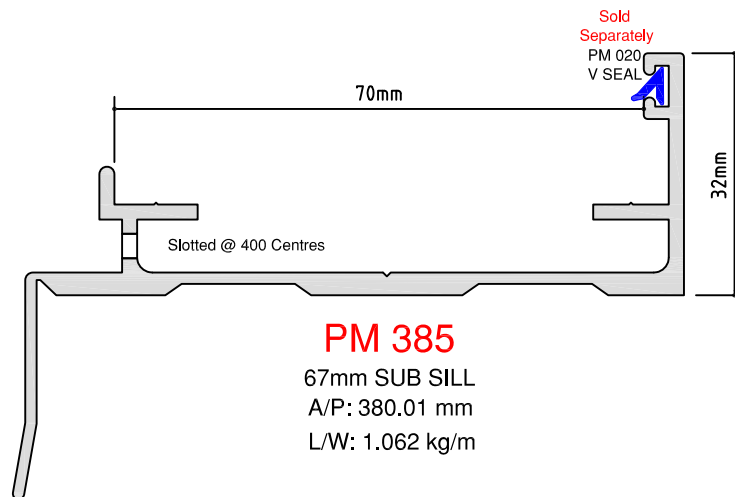
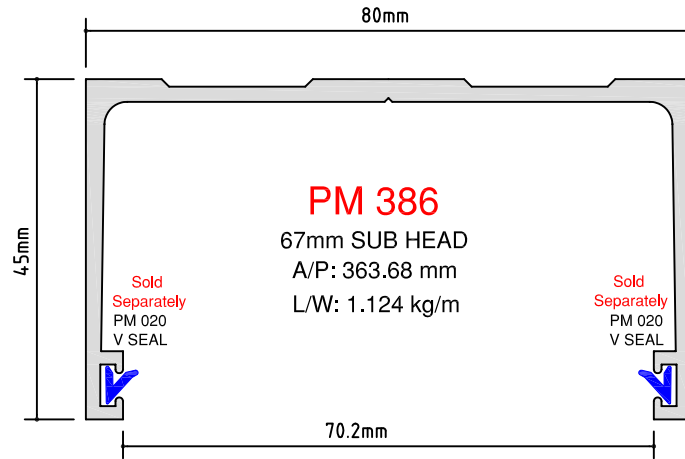

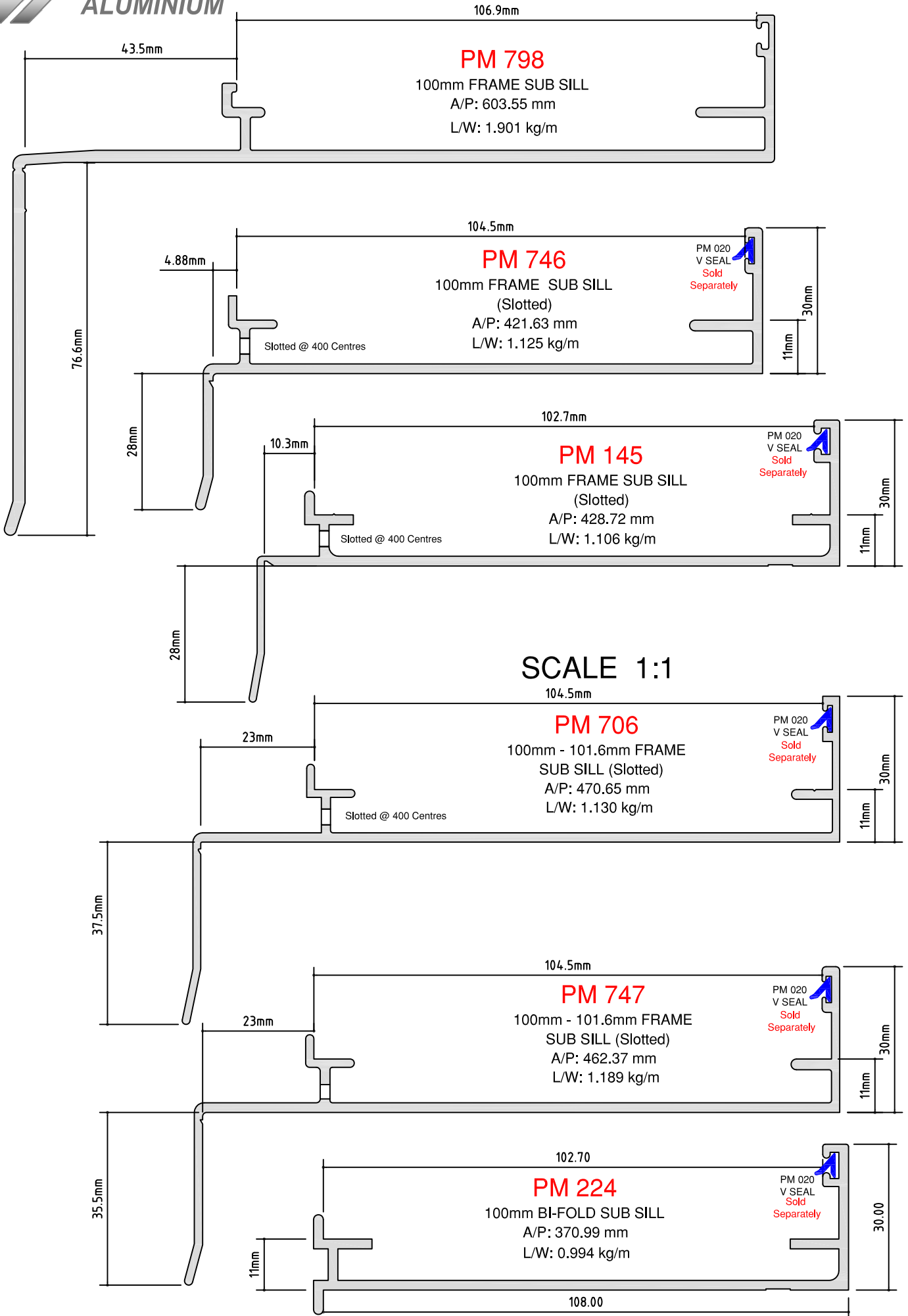

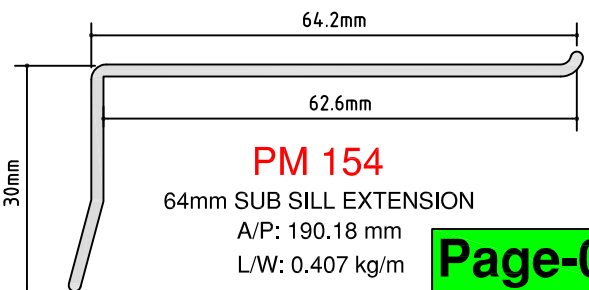
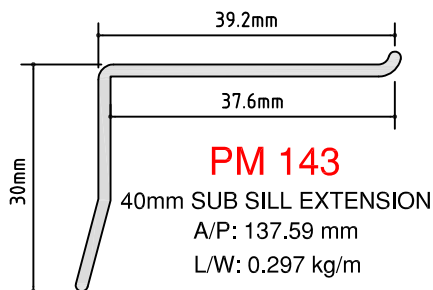
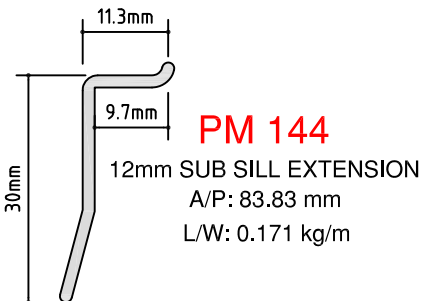
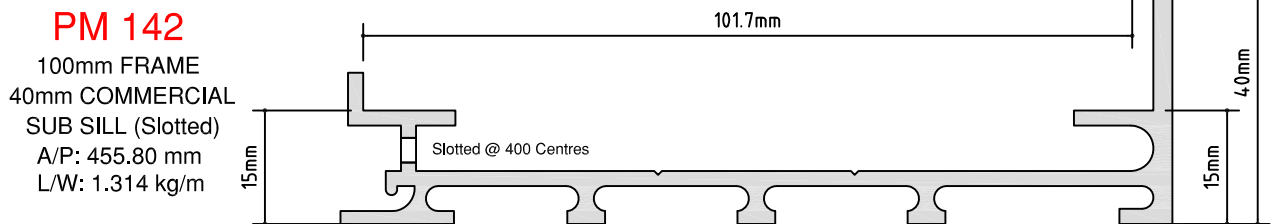
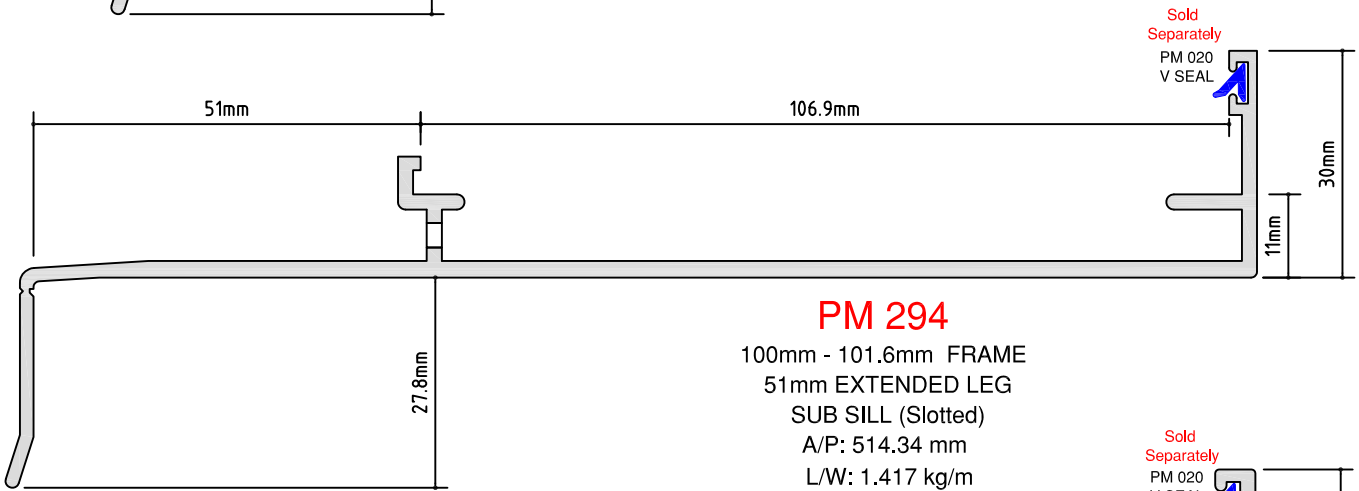
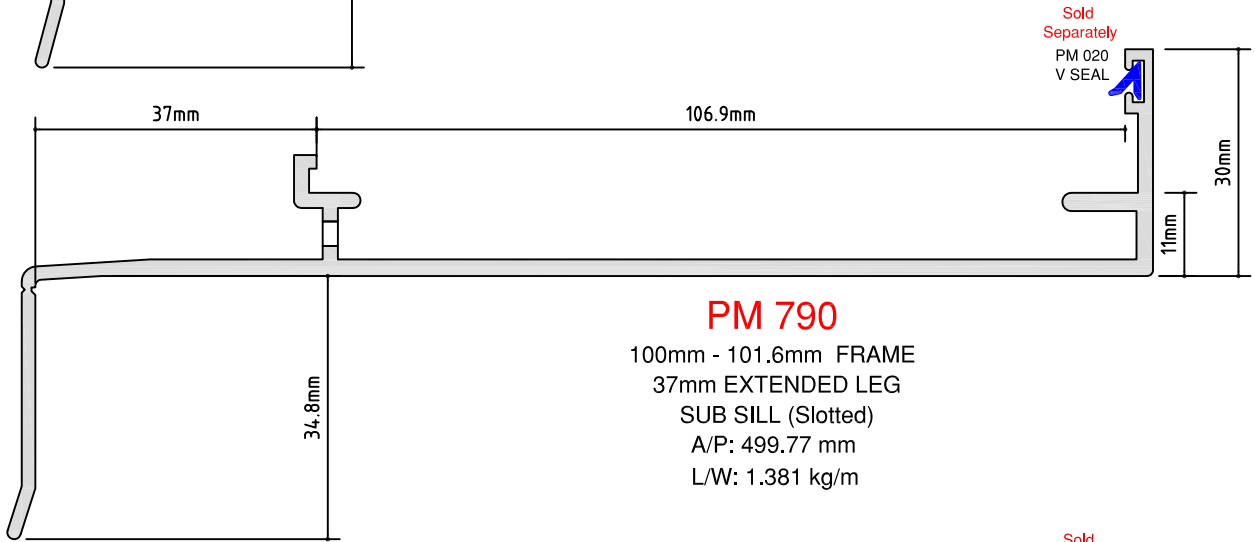
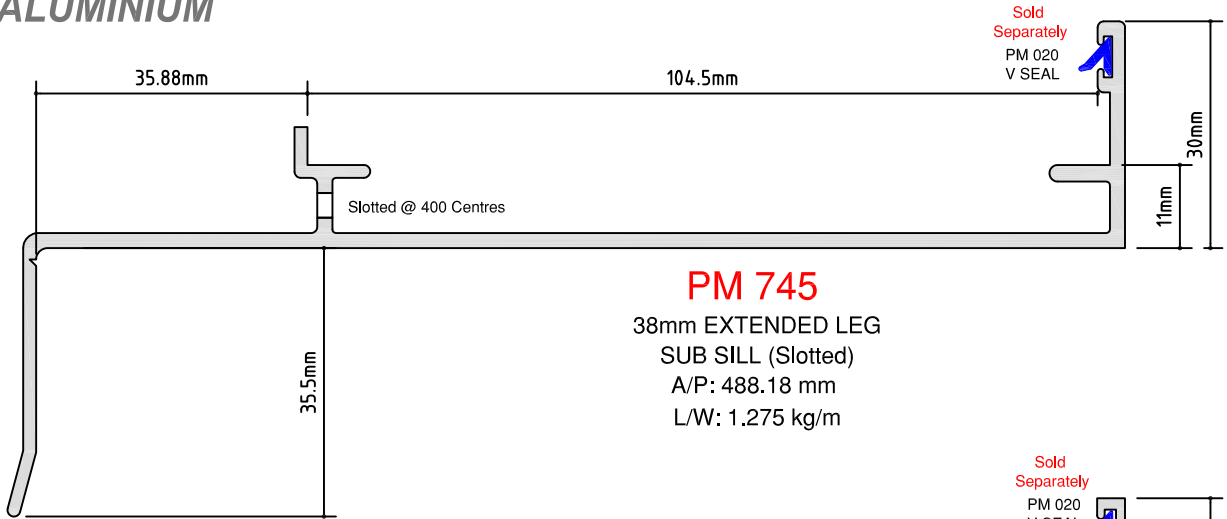

SCALE 1:1

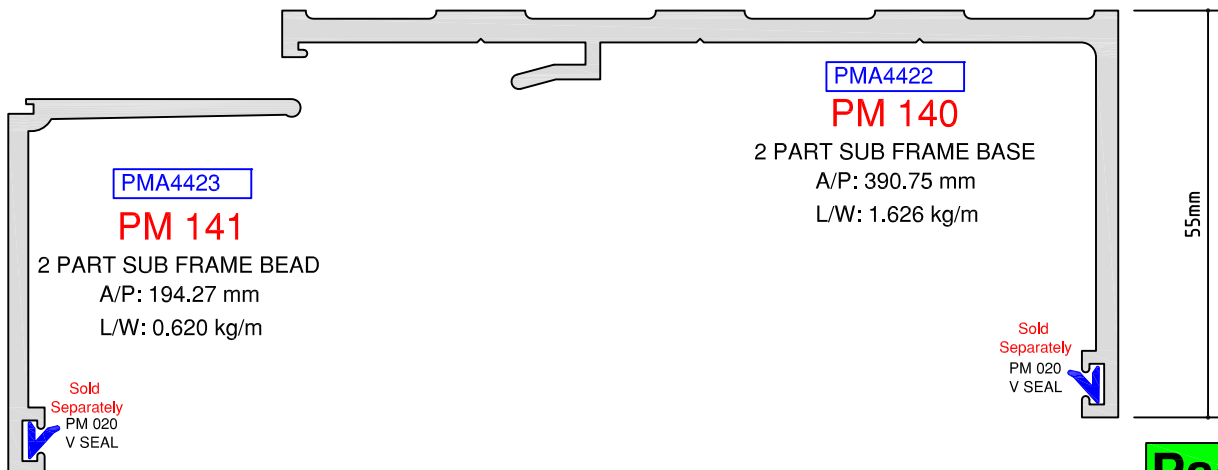
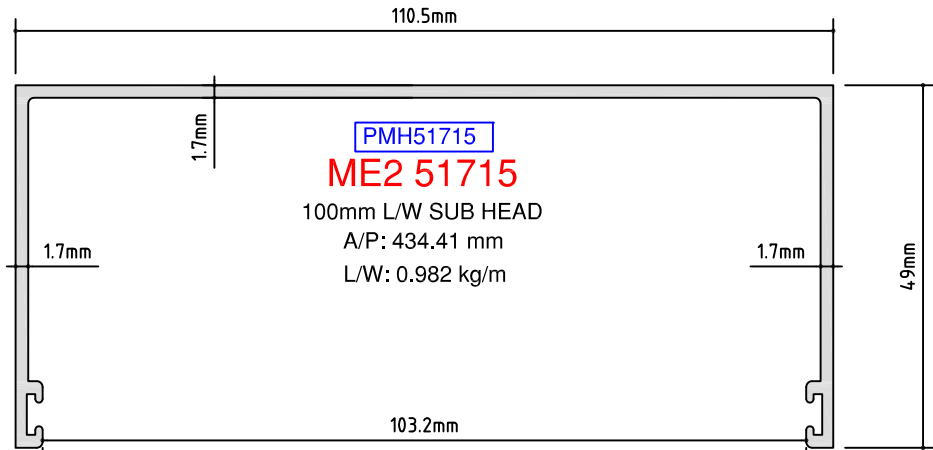
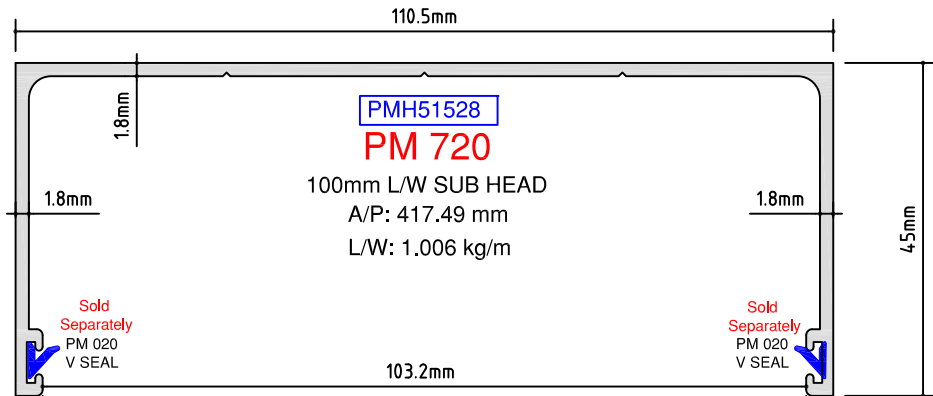
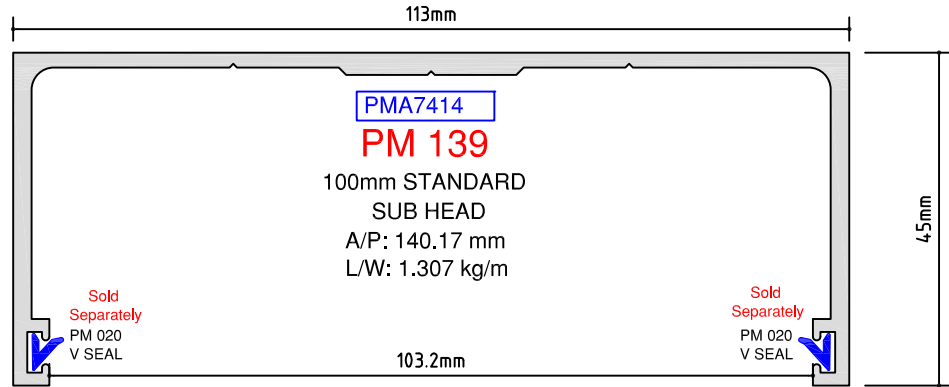

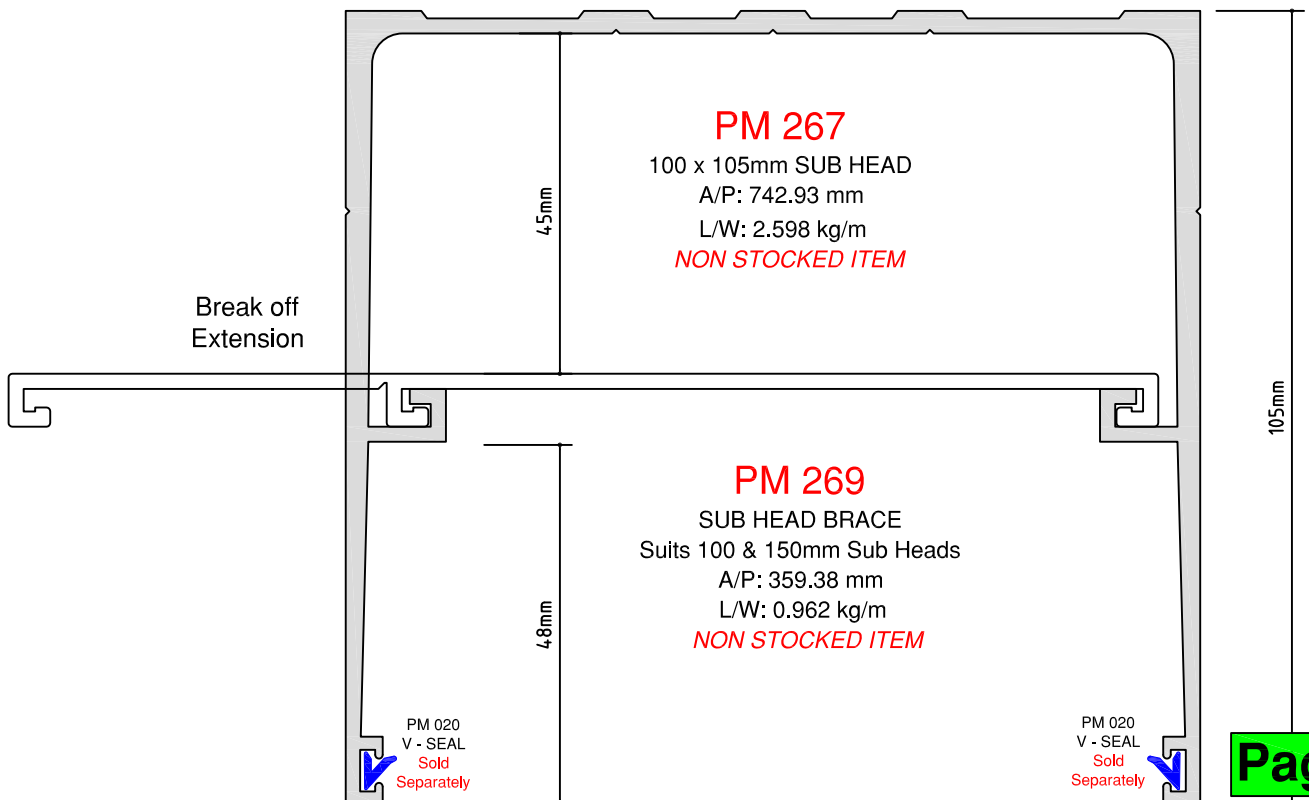
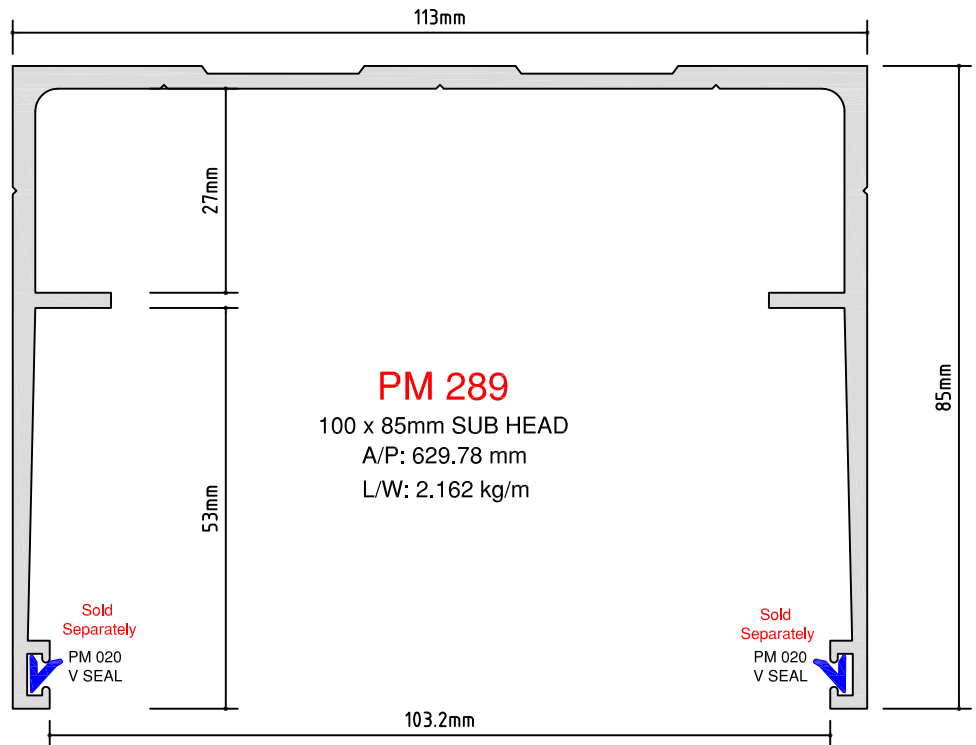
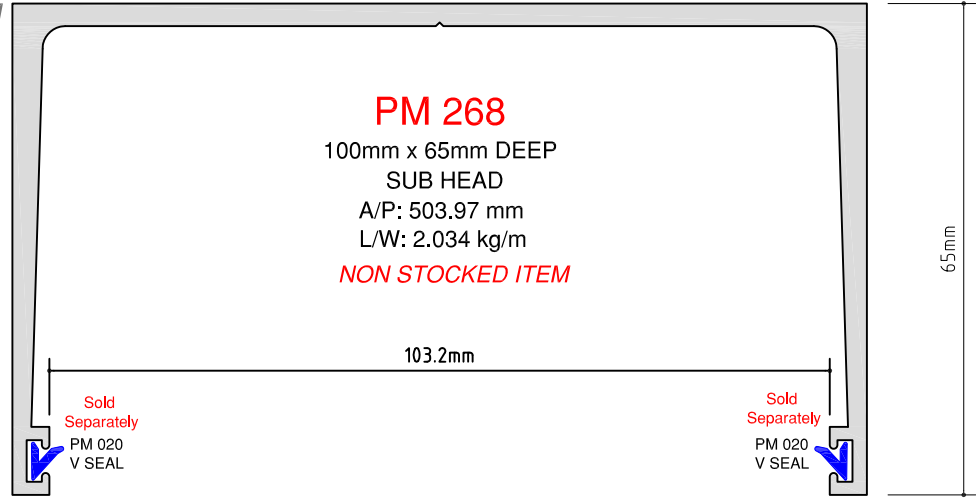

SCALE 1:1

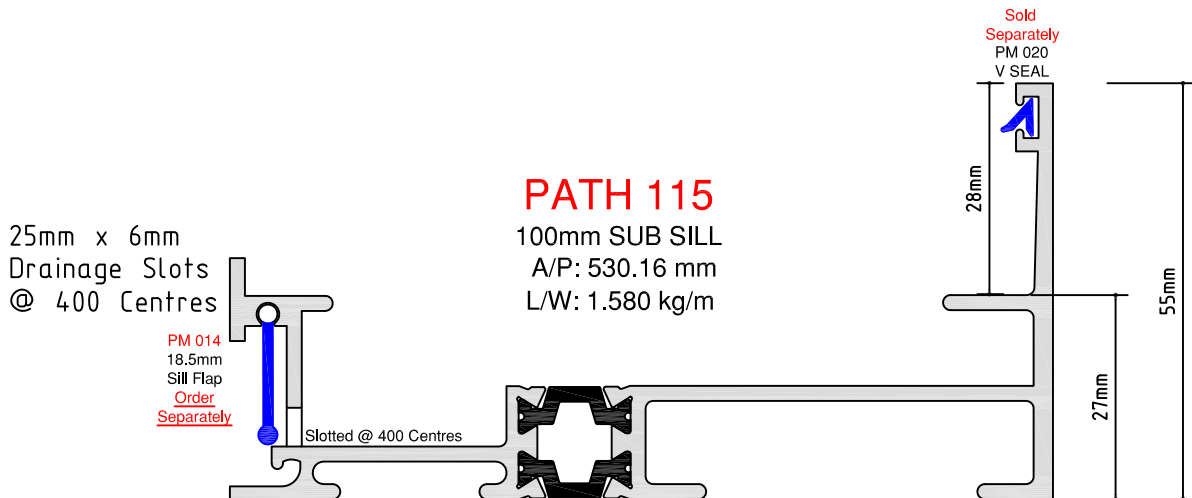
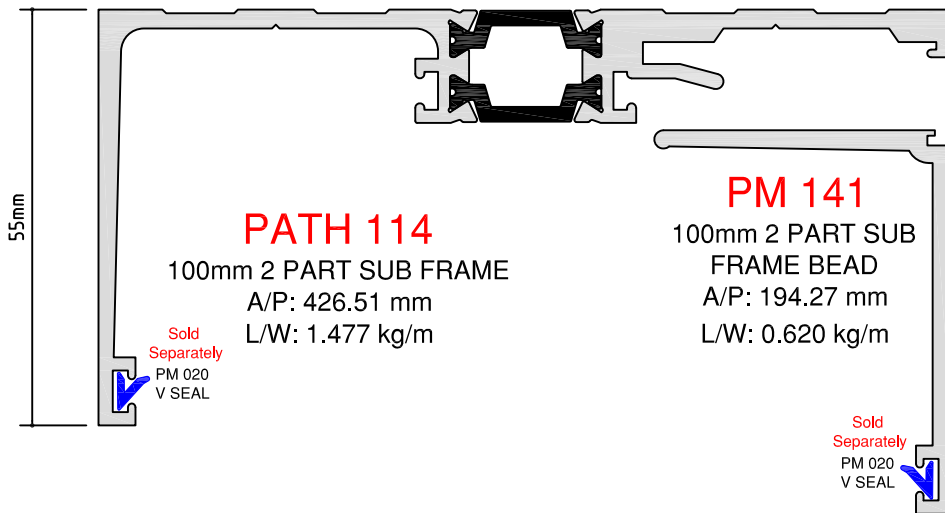
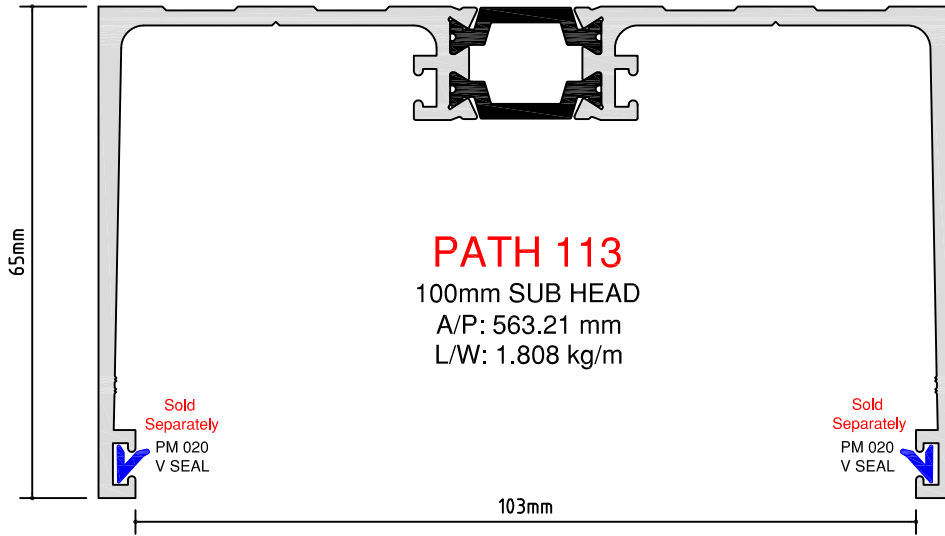

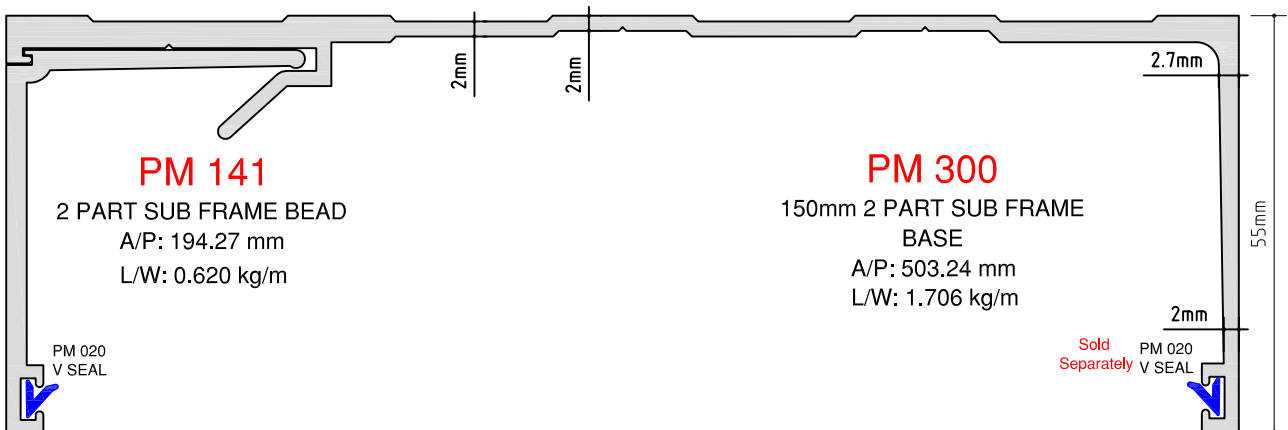
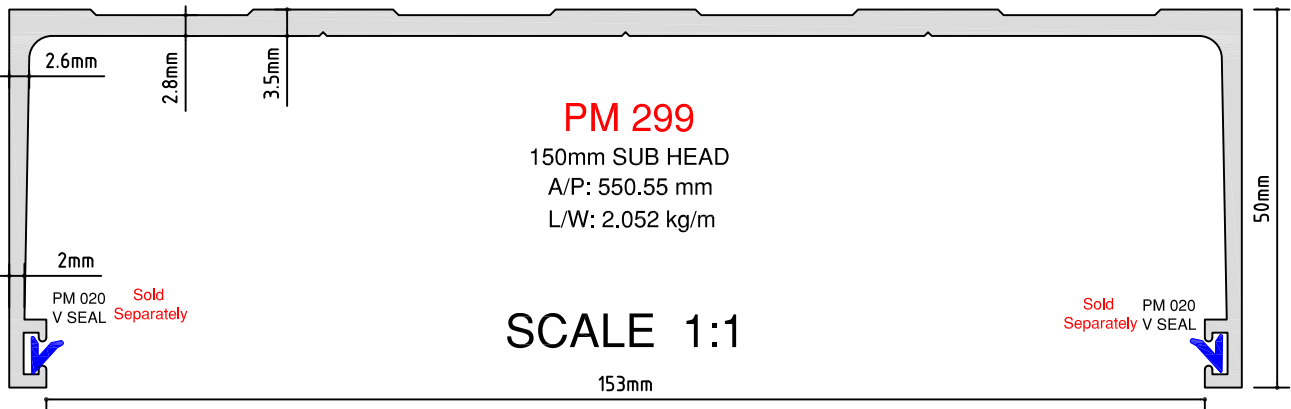
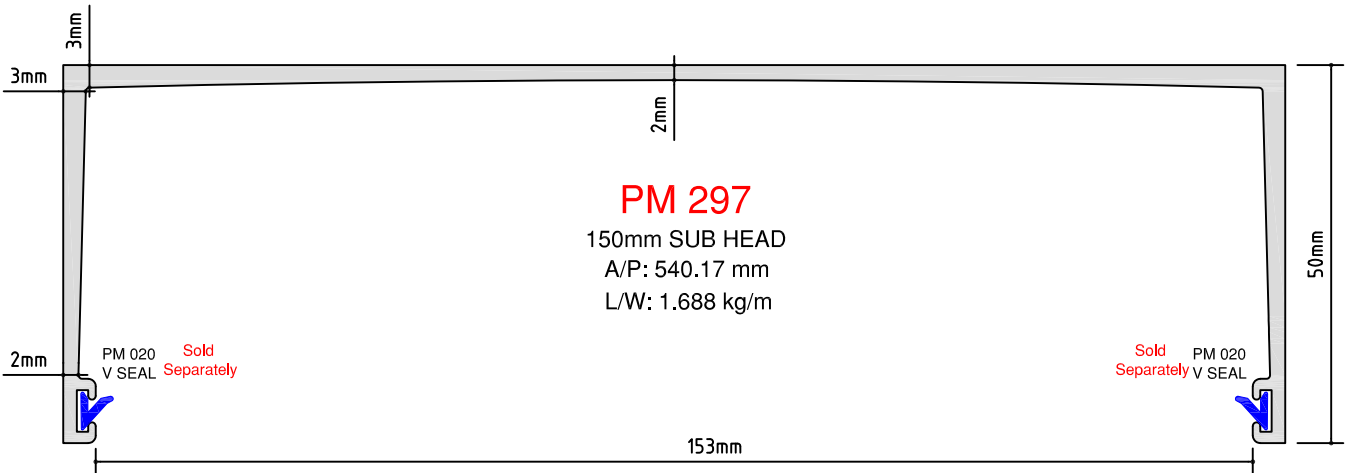
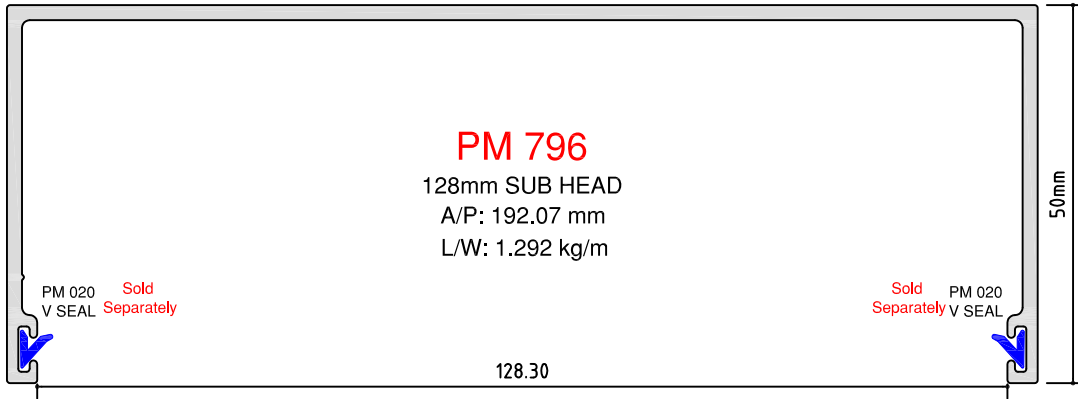

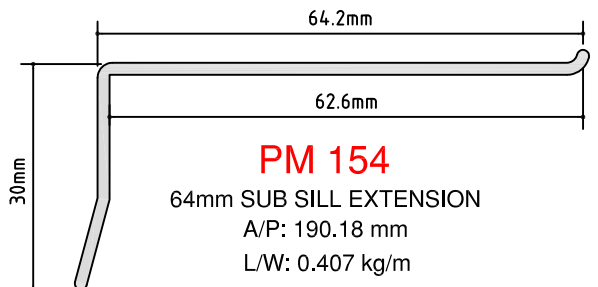
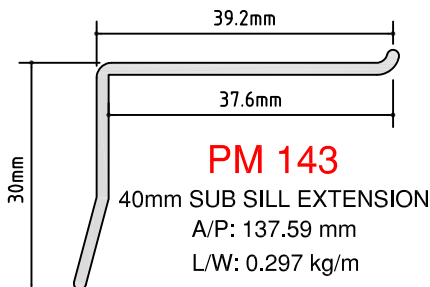
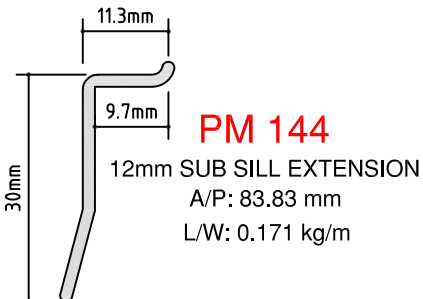
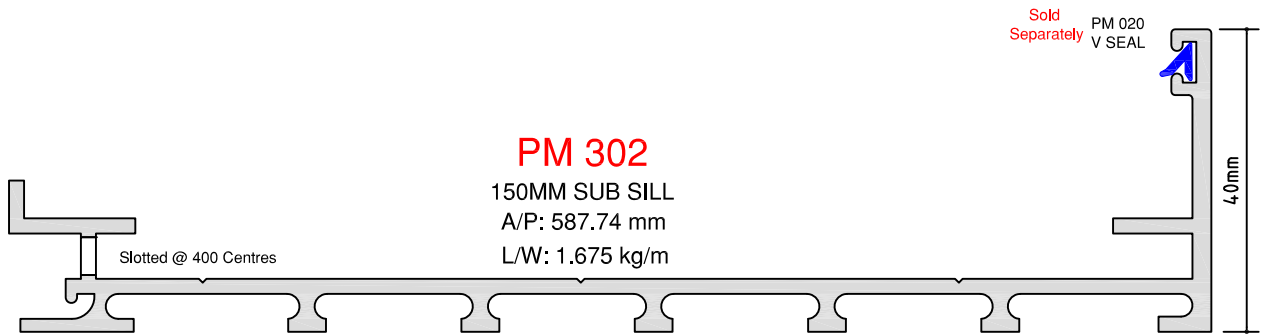
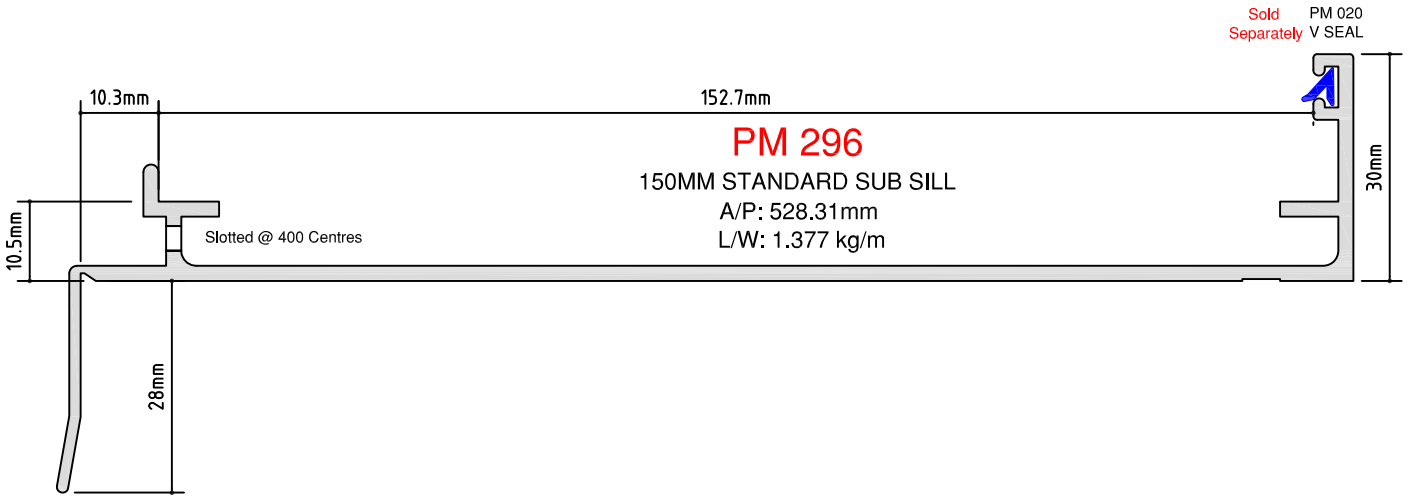

SCALE 1:1

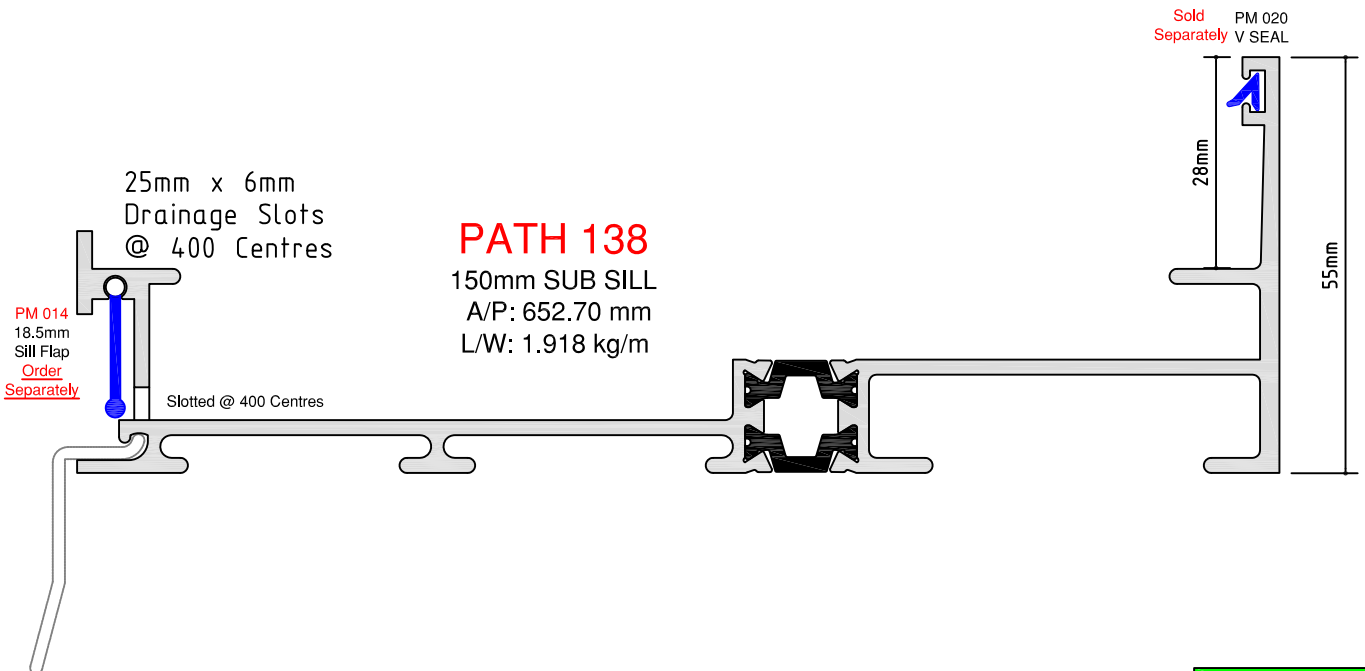
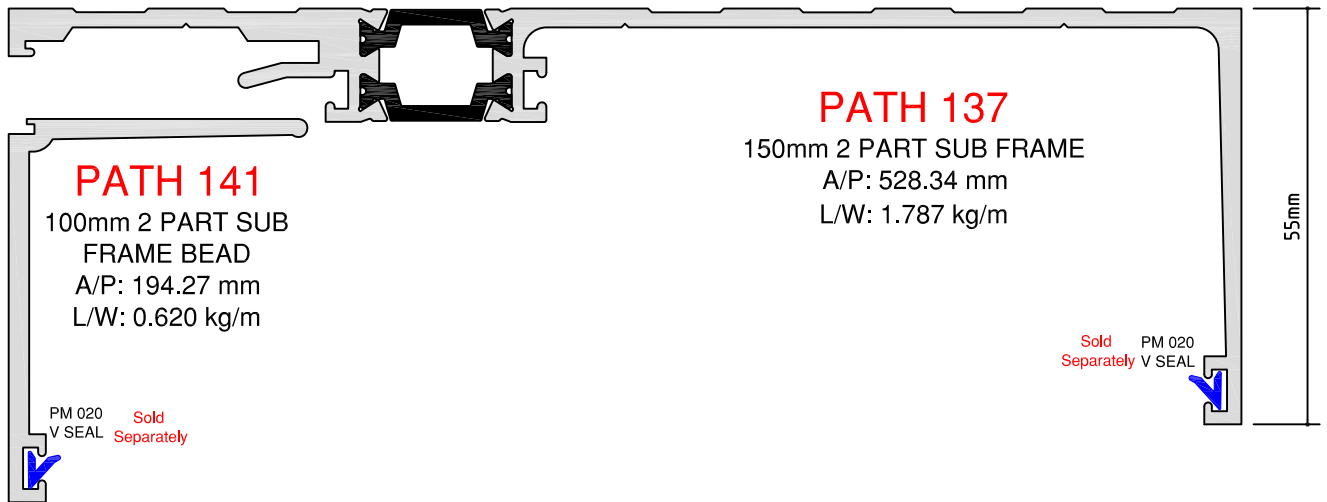
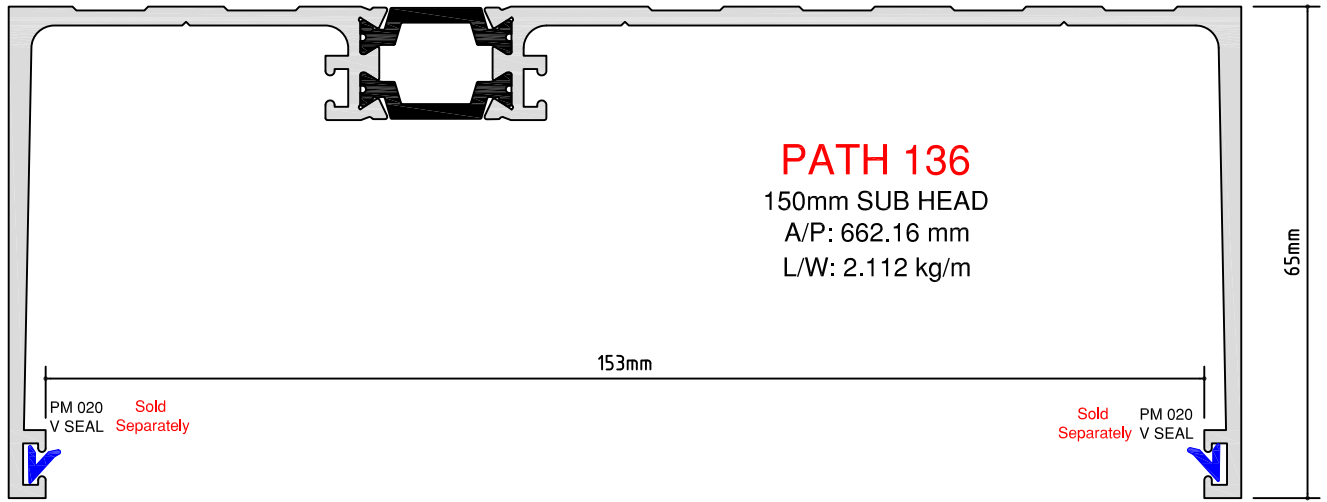

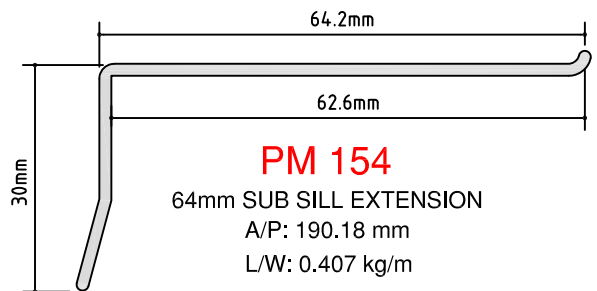
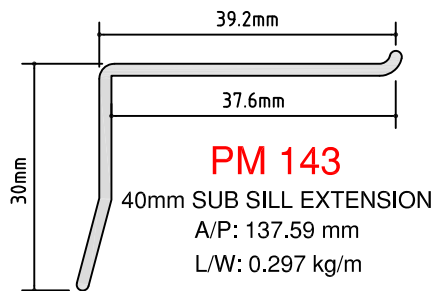
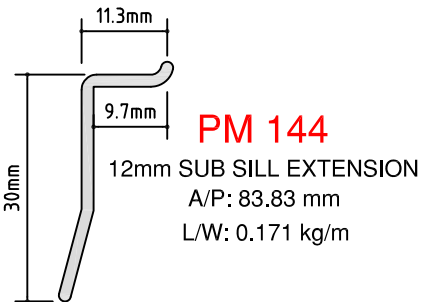
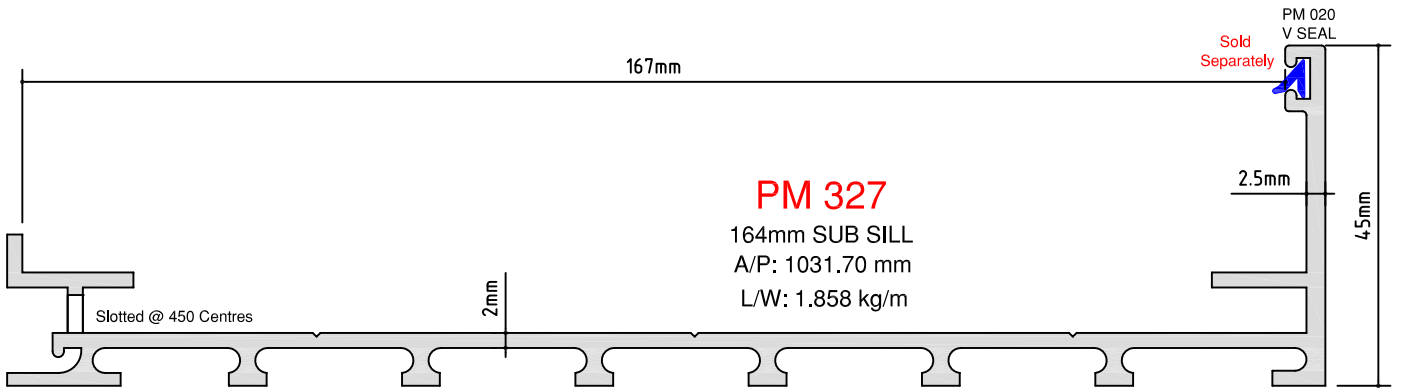
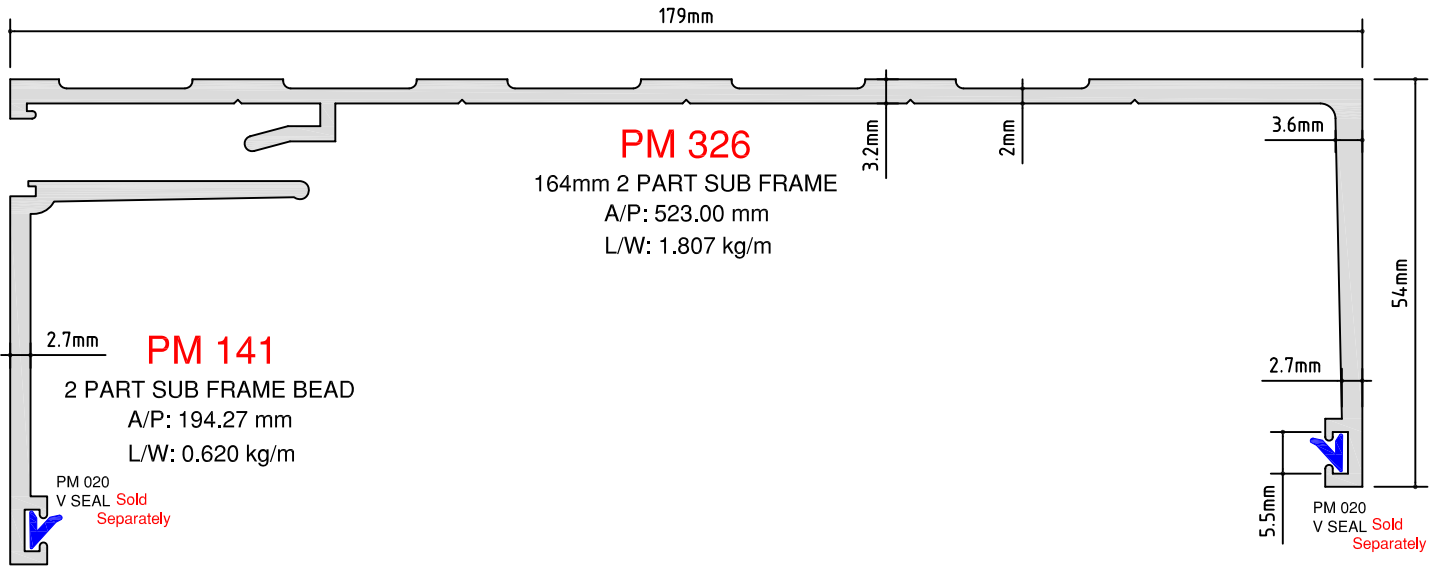

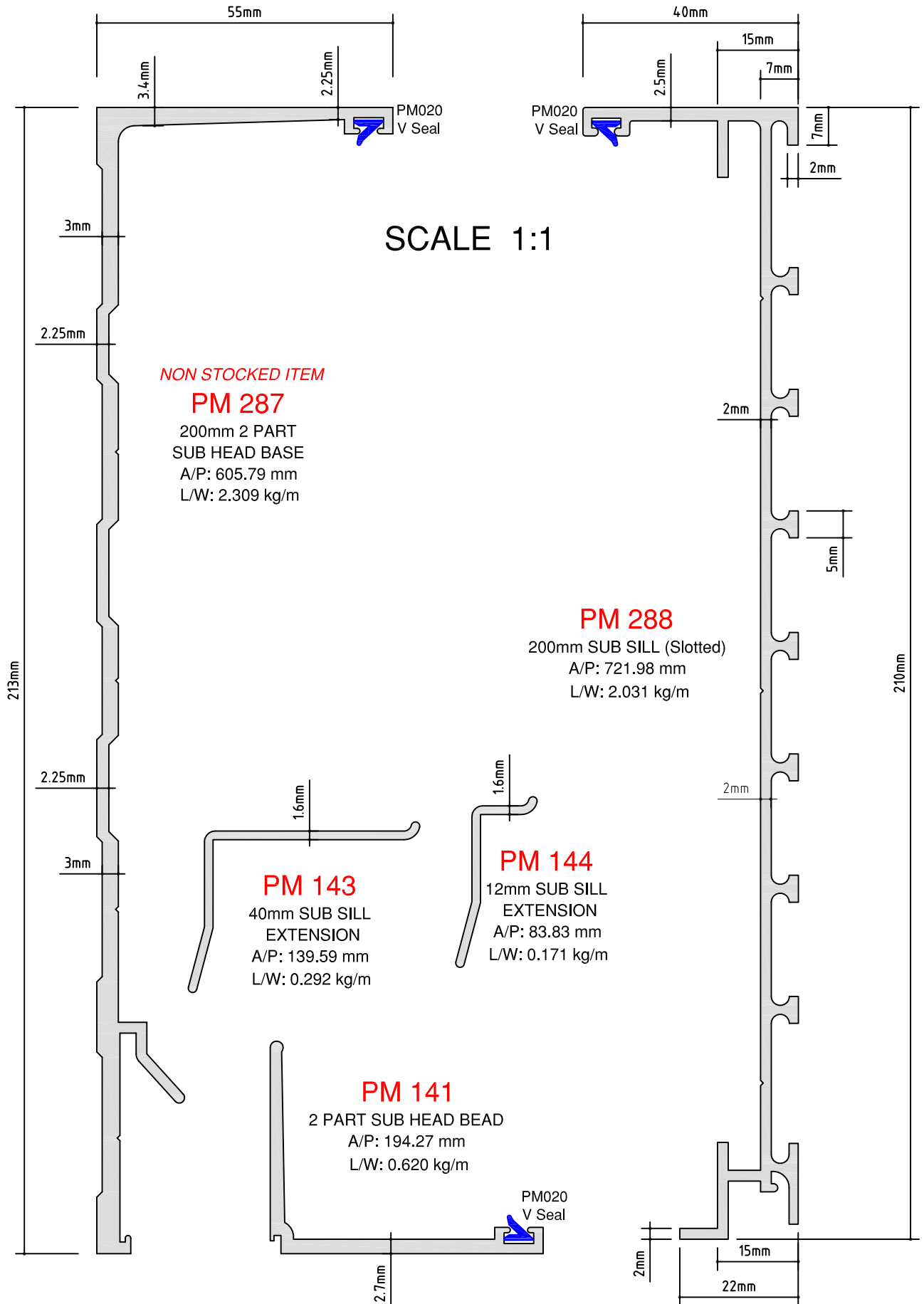

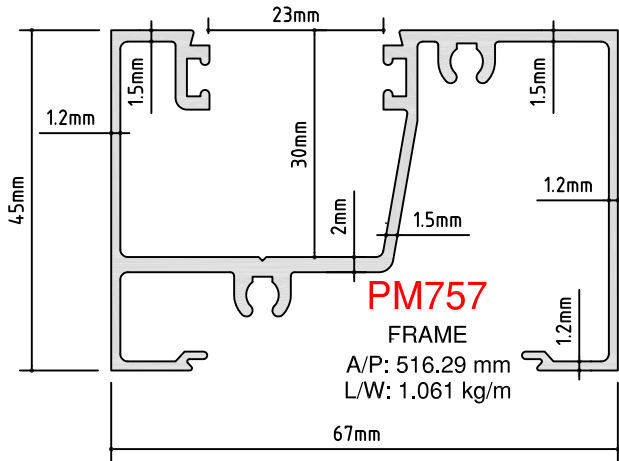

SCALE 1:1

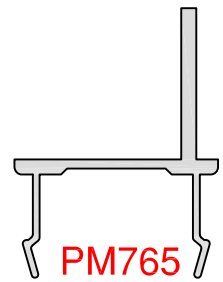
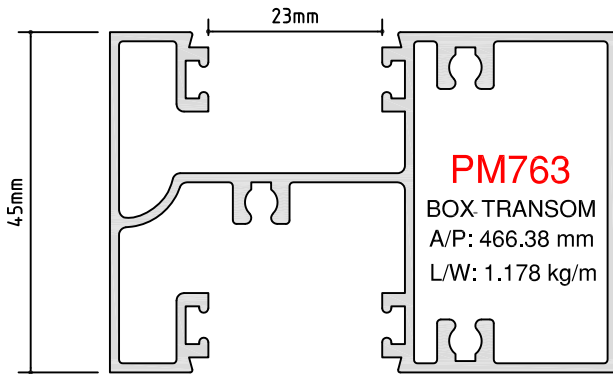
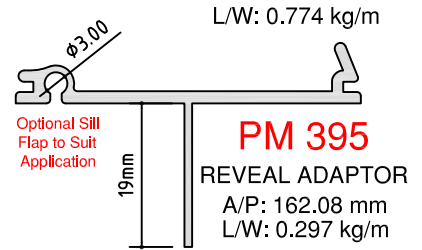

AWNING SASH ADAPTOR
A/P: 157.98 mm
L/W: 0.301 kg/m

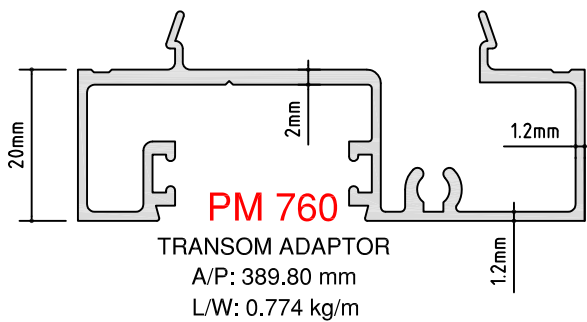
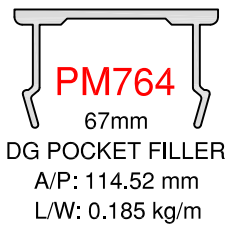
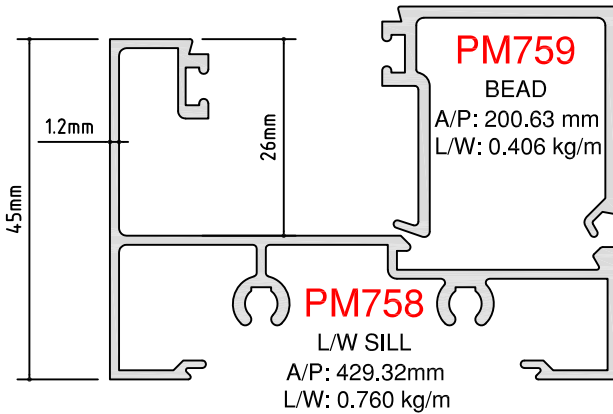

SCALE 1:1

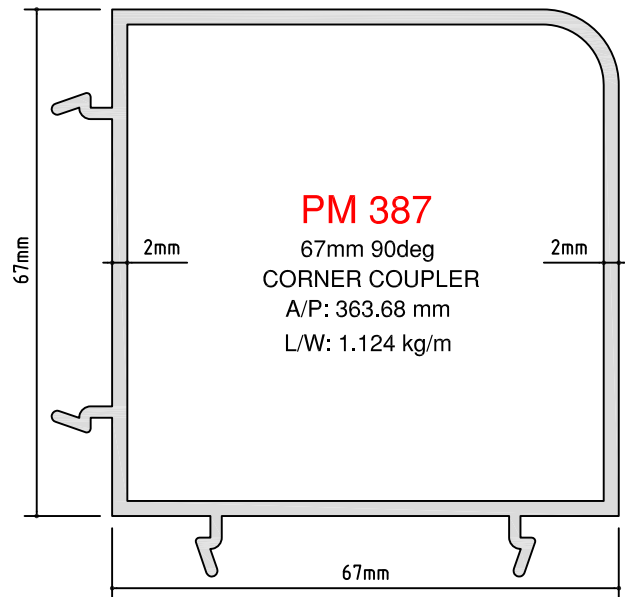
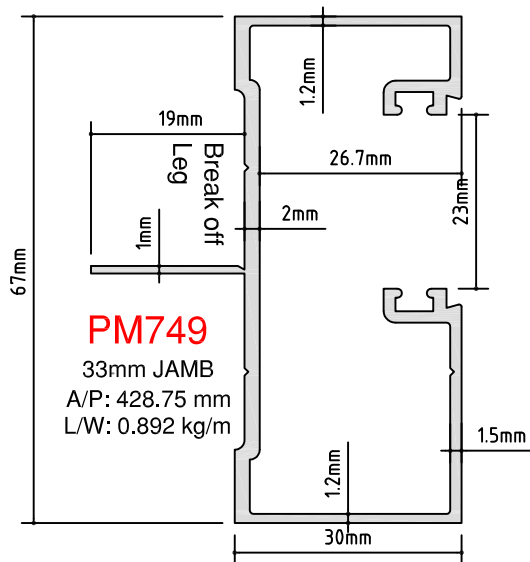
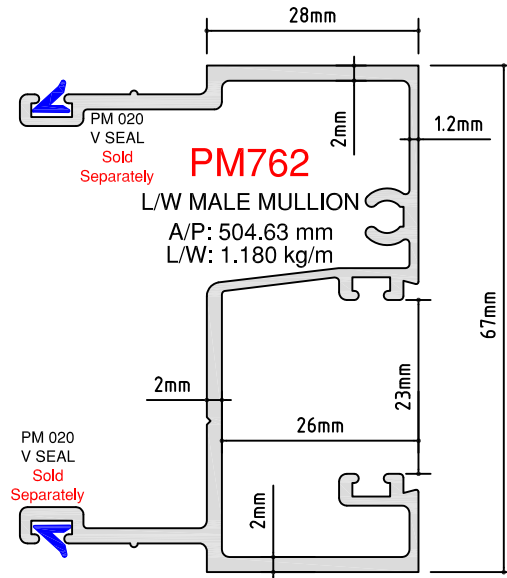
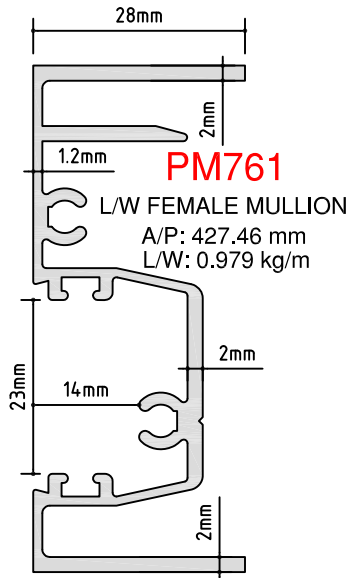

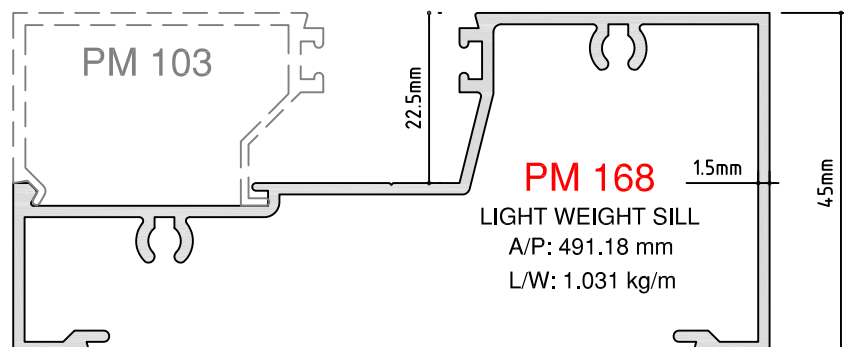
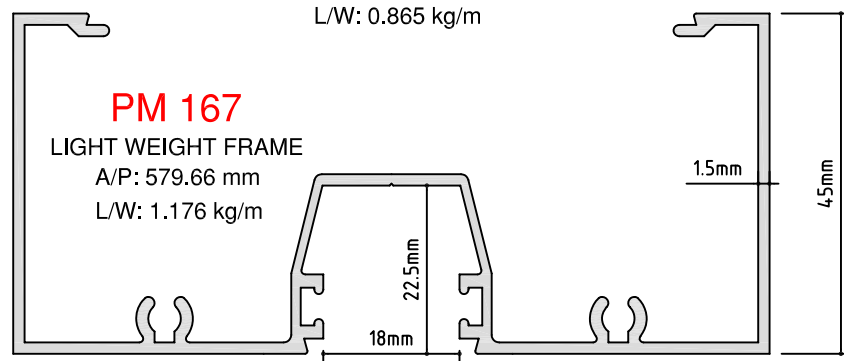
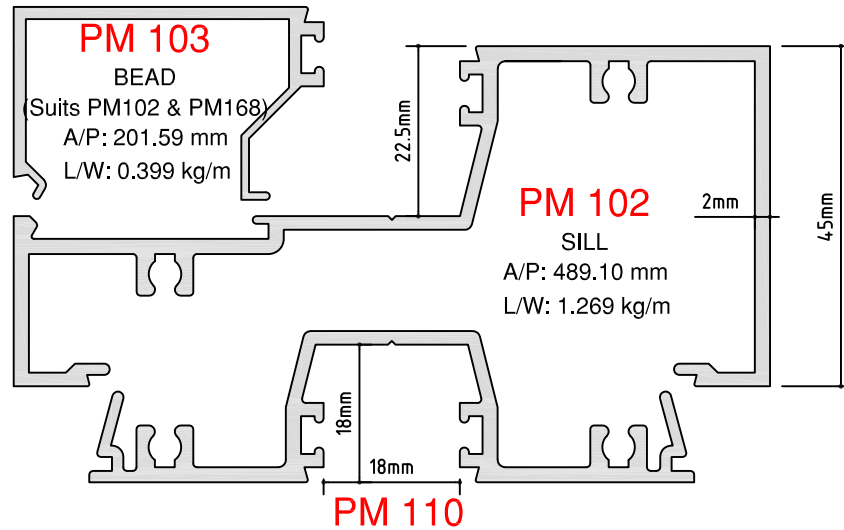
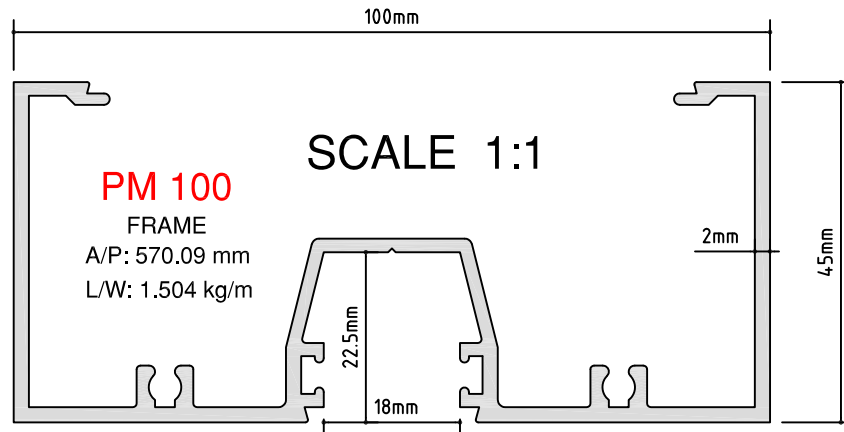



SCALE 1:1

PM 106
25mm FRAME
A/P: 484.99 mm
L/W: 1.275 kg/m

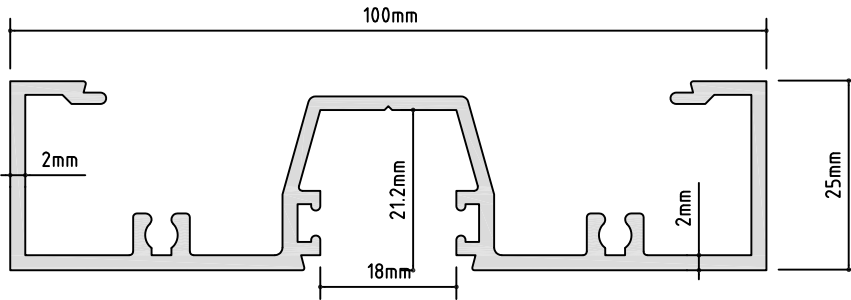

PM 111
PLAIN FRAME
A/P: 464.23 mm
L/W: 1.244 kg/m

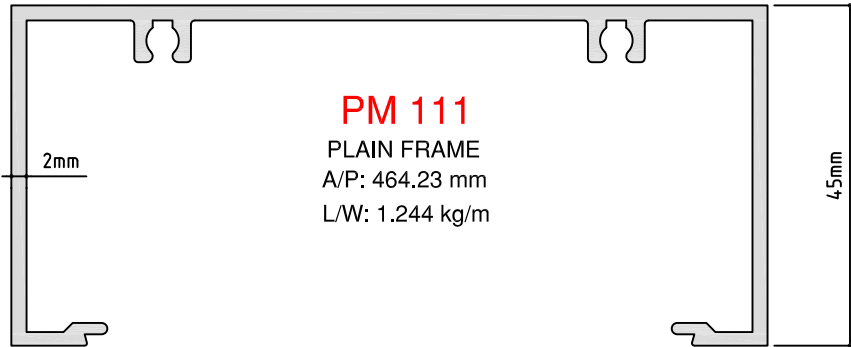

PM 411
25mm PLAIN FRAME
A/P: 384.23 mm
L/W: 1.027 kg/m

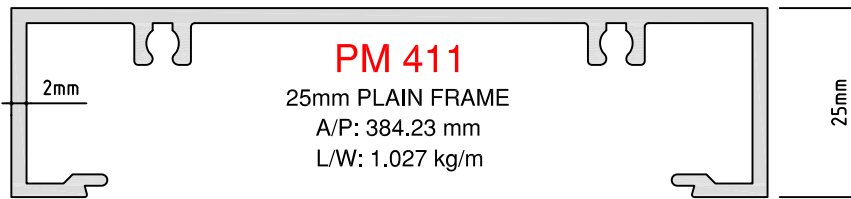

PM 118
90 Deg CORNER POST
A/P: 485.02 mm
L/W: 2.359 kg/m

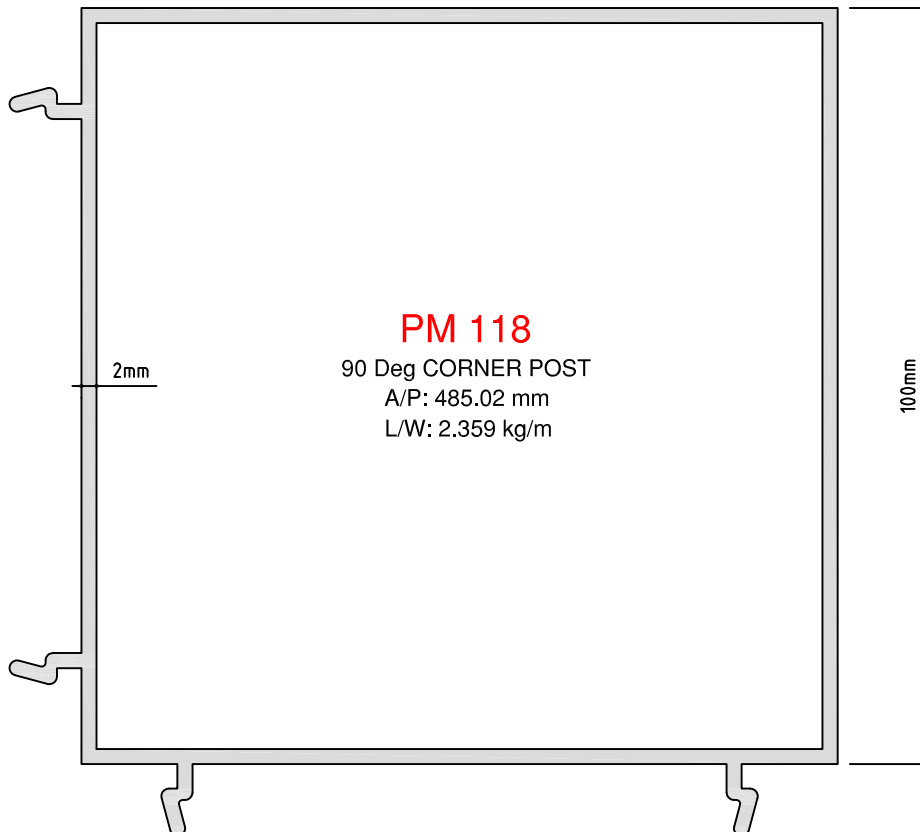

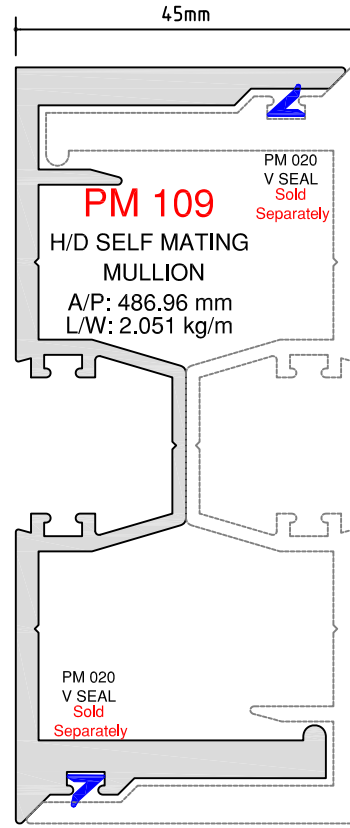
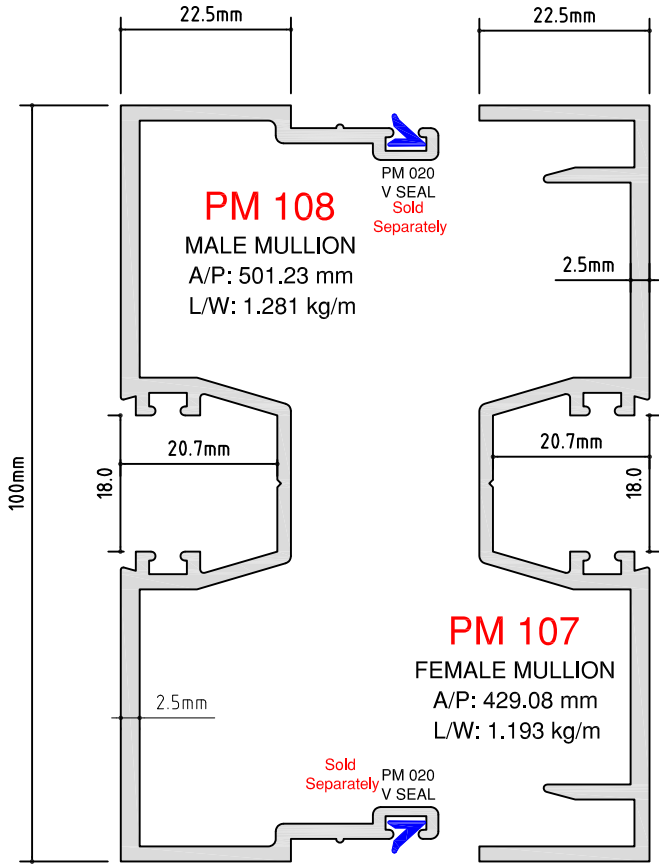

SCALE 1:1

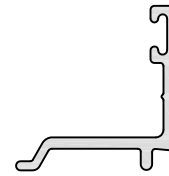
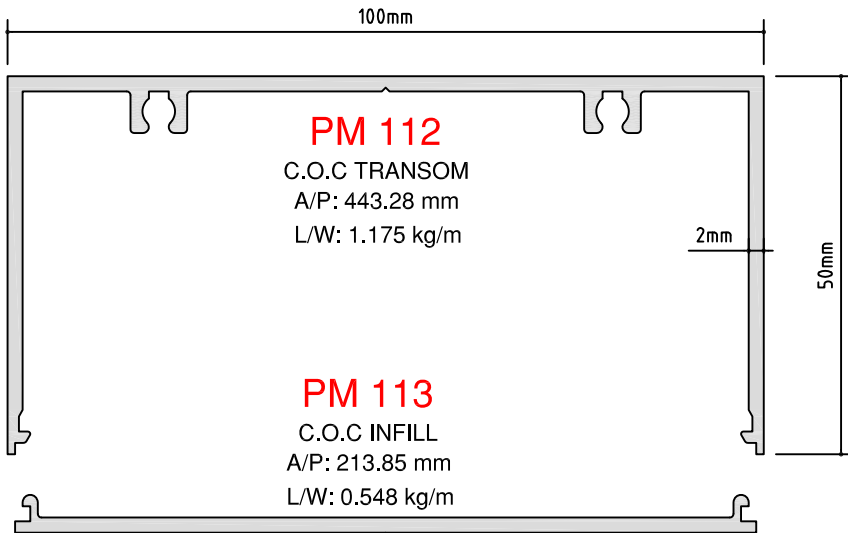

PM 123
CHANNEL BEAD
A/P: 102.97 mm
L/W: 0.262 kg/m

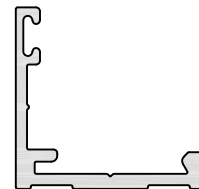

PM 122
CHANNEL BASE
A/P: 149.74 mm
L/W: 0.388 kg/m

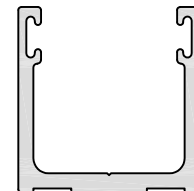

PM 124
CHANNEL
A/P: 183.47 mm
L/W: 0.480 kg/m

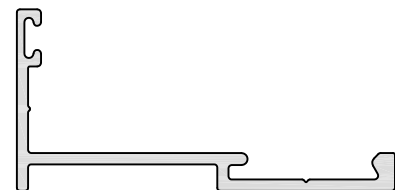

PM 322
DG CHANNEL BASE
A/P: 174.78 mm
L/W: 0.352 kg/m

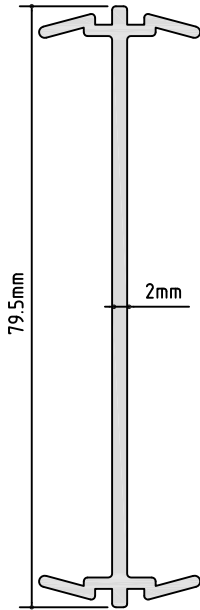

PM 114
100mm FRAME
COUPLER
(Suits All 100mm
PM Sections)
A/P: 245.89 mm
L/W: 0.609 kg/m



PM 105
100mm FLAT INFILL
A/P: 202.91 mm
L/W: 0.430 kg/m

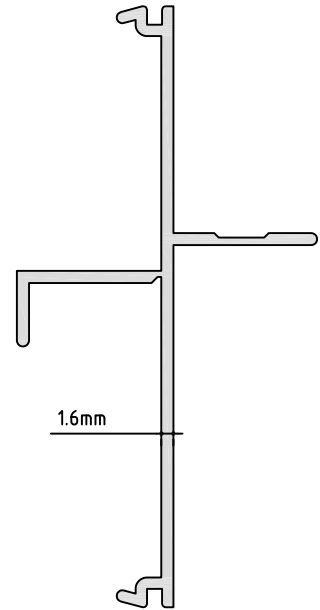

PM 115
100mm REVEAL
ADAPTOR
A/P: 294.26 mm
L/W: 0.613 kg/m

SCALE 1:1

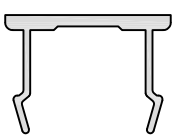

PM 116
POCKET INFILL
A/P: 104.23 mm
L/W: 0.177 kg/m

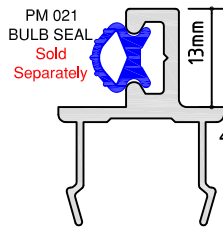

PM 117
45mm DOOR STOP
A/P: 143.11 mm
L/W: 0.311 kg/m

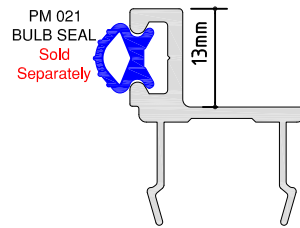

PM 135
35mm DOOR STOP
A/P: 145.05 mm
L/W: 0.311 kg/m

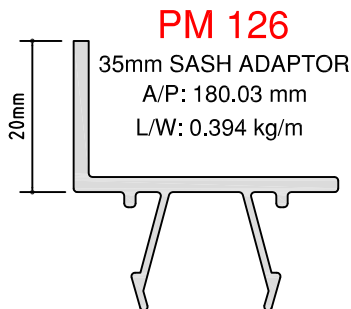

PM 126
35mm SASH ADAPTOR
A/P: 180.03 mm
L/W: 0.394 kg/m

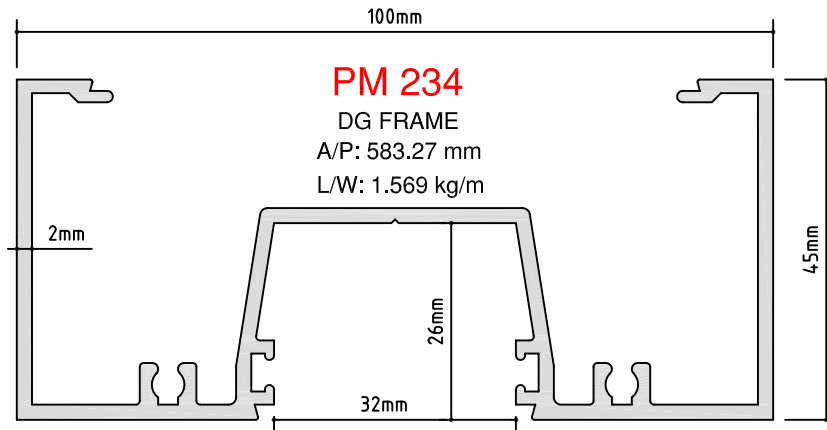

SCALE 1:1

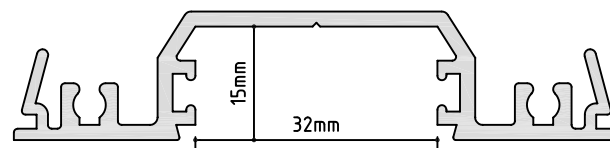
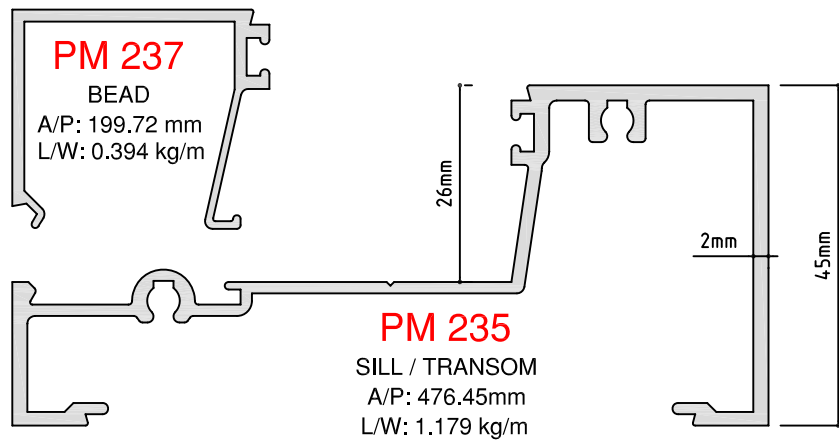

PM 236
GLAZING ADAPTOR
A/P: 330.53 mm
L/W: 0.848 kg/m

SCALE 1:1

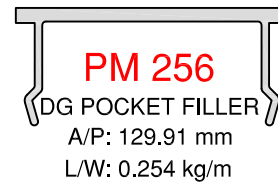
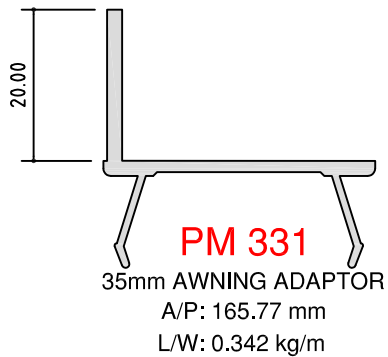
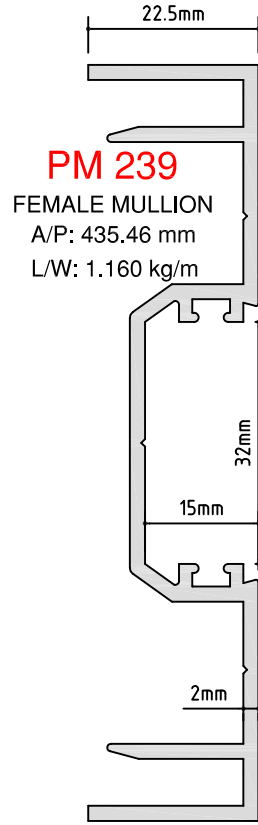
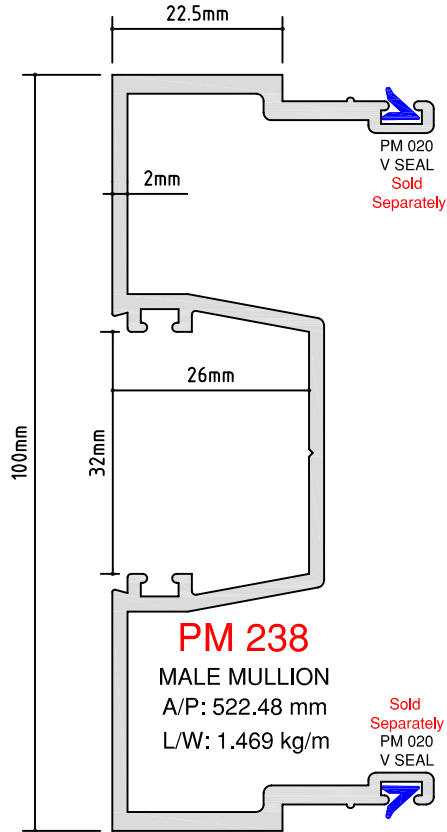

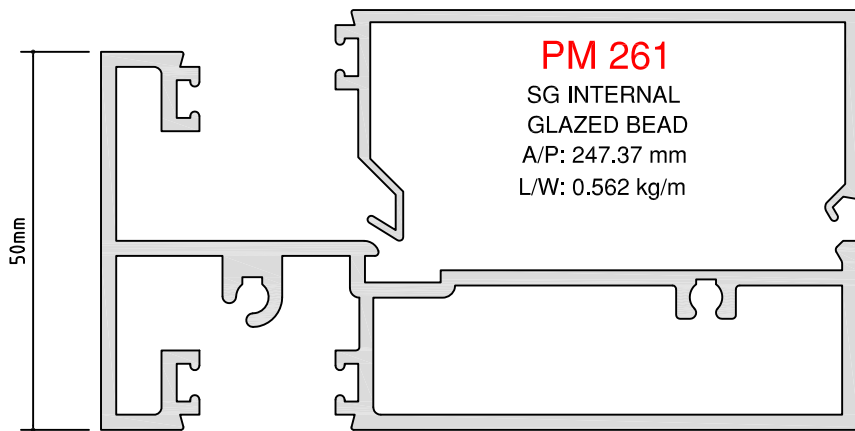
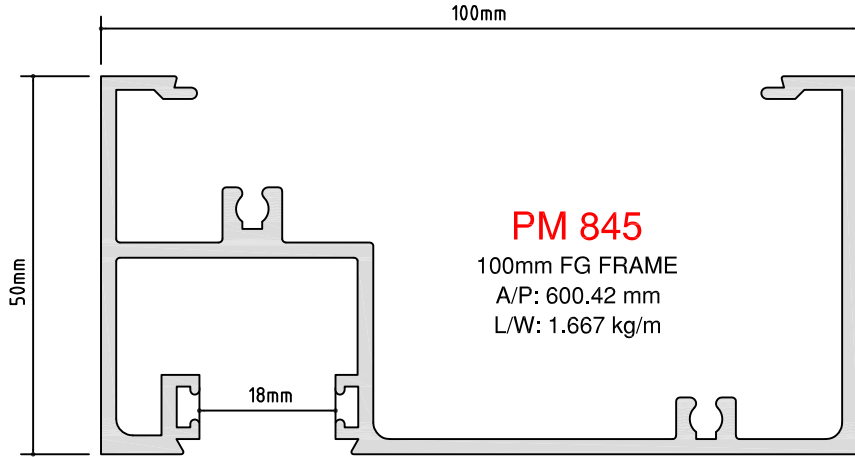

PM 846
100mm FG SILL / TRANSOM
INTERNAL GLAZED
A/P: 495.35 mm
L/W: 1.860 kg/m

PM 291
FG EXTERNAL BEAD
A/P: 149.22 mm
L/W: 0.343 kg/m

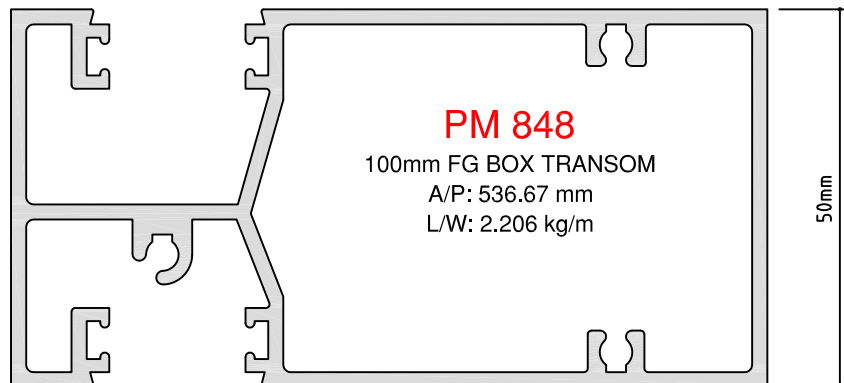
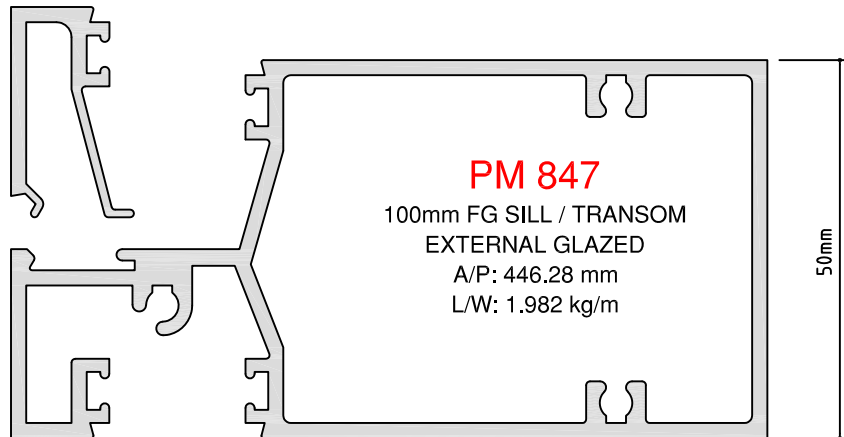

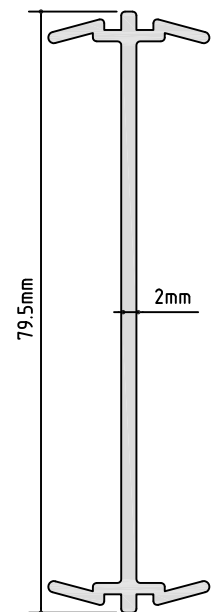
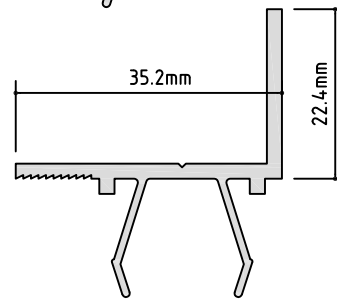
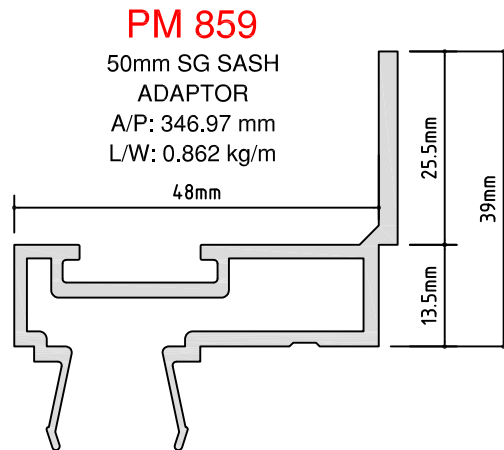
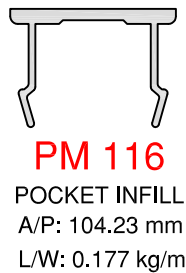
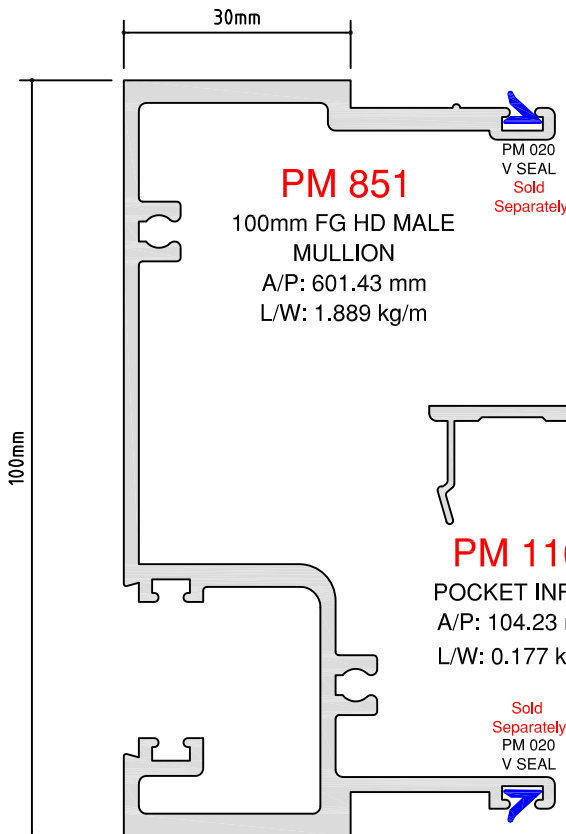
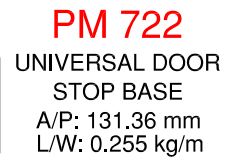
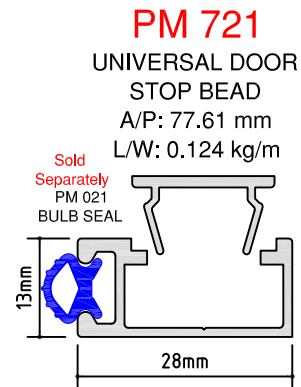
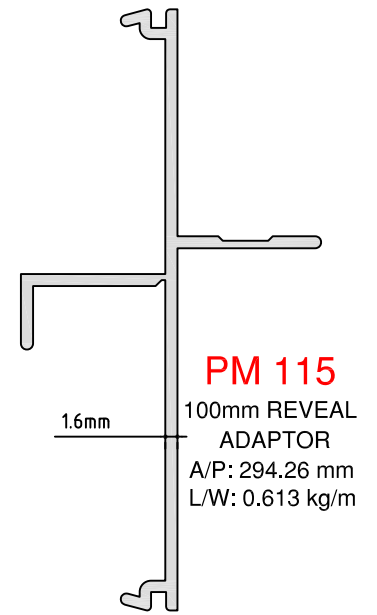
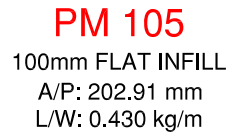
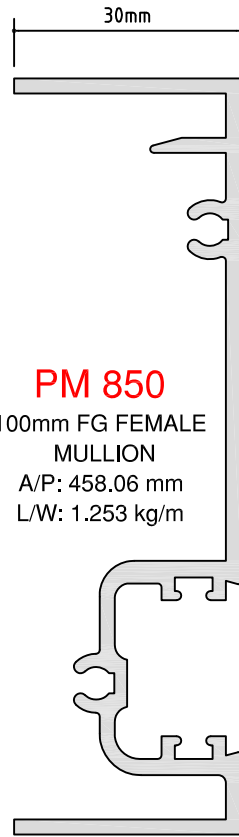
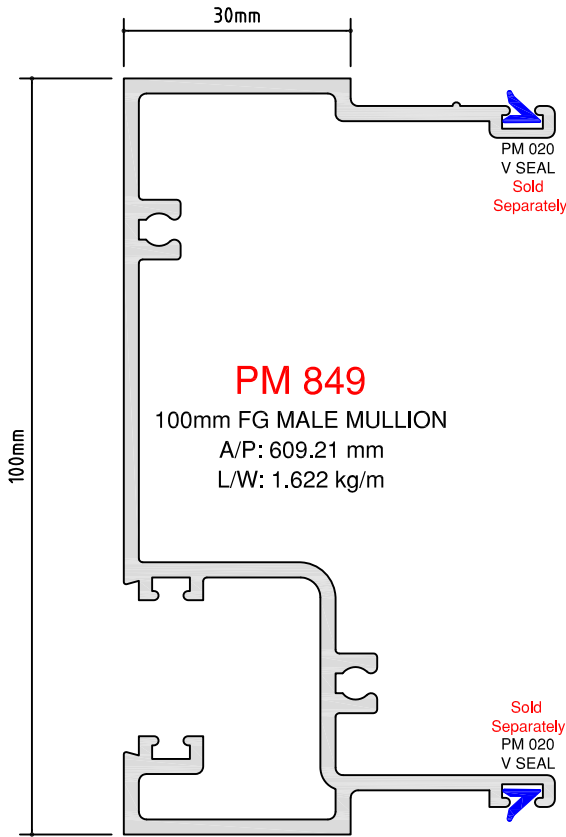

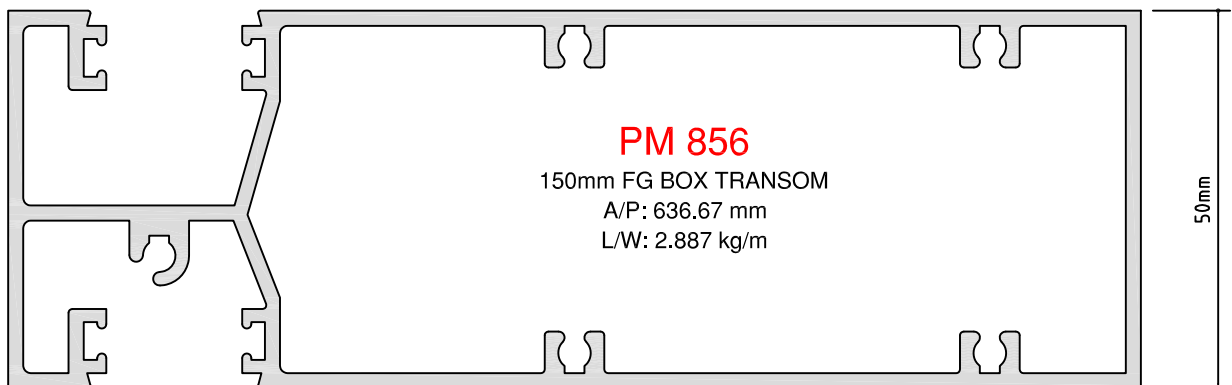
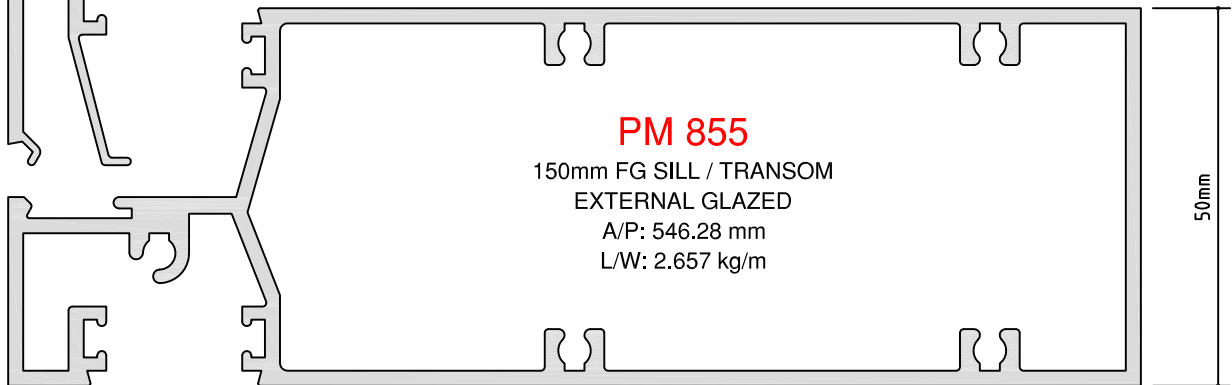
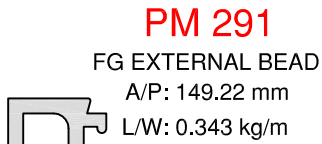
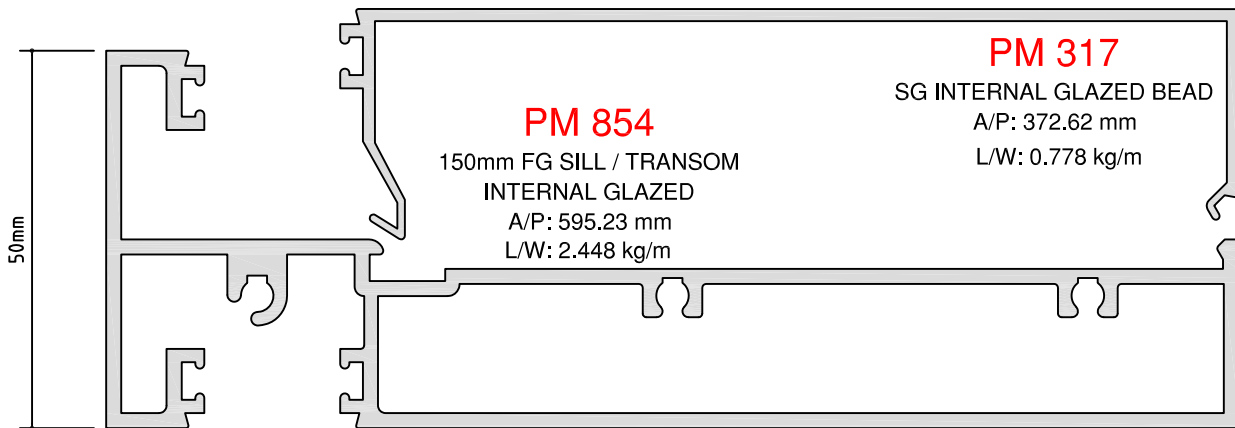
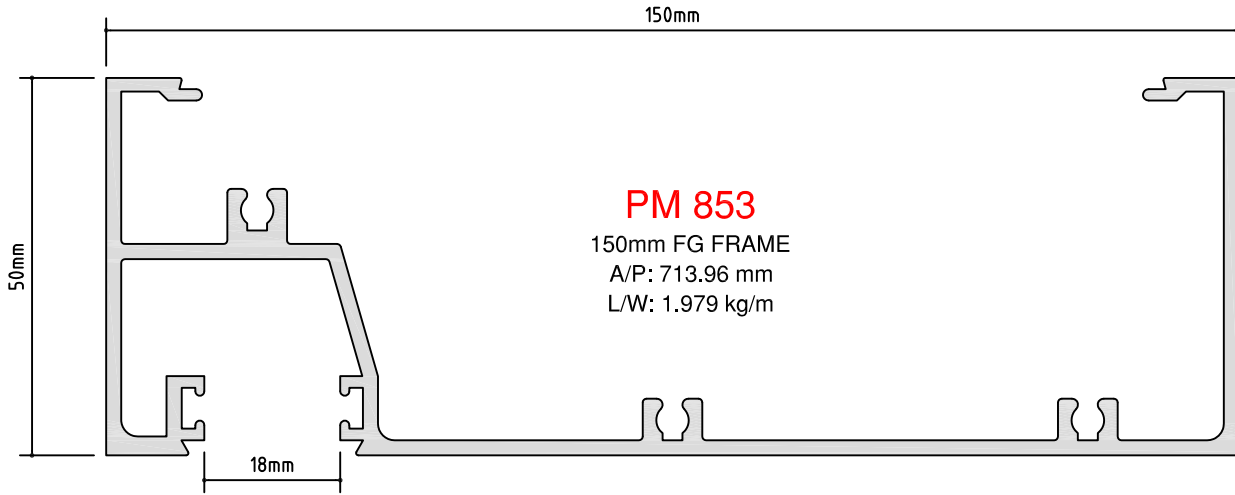

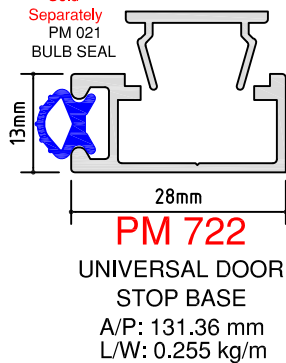
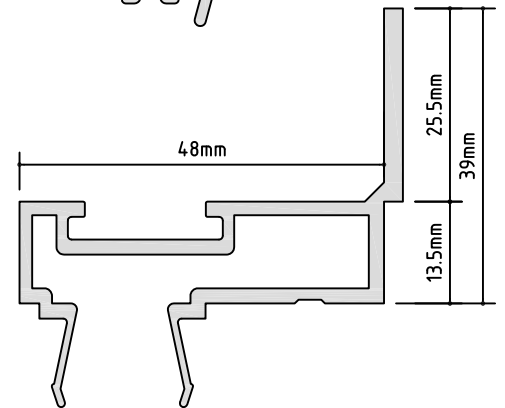
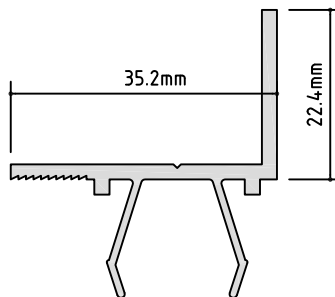
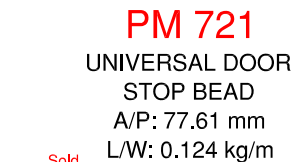
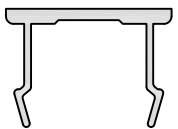
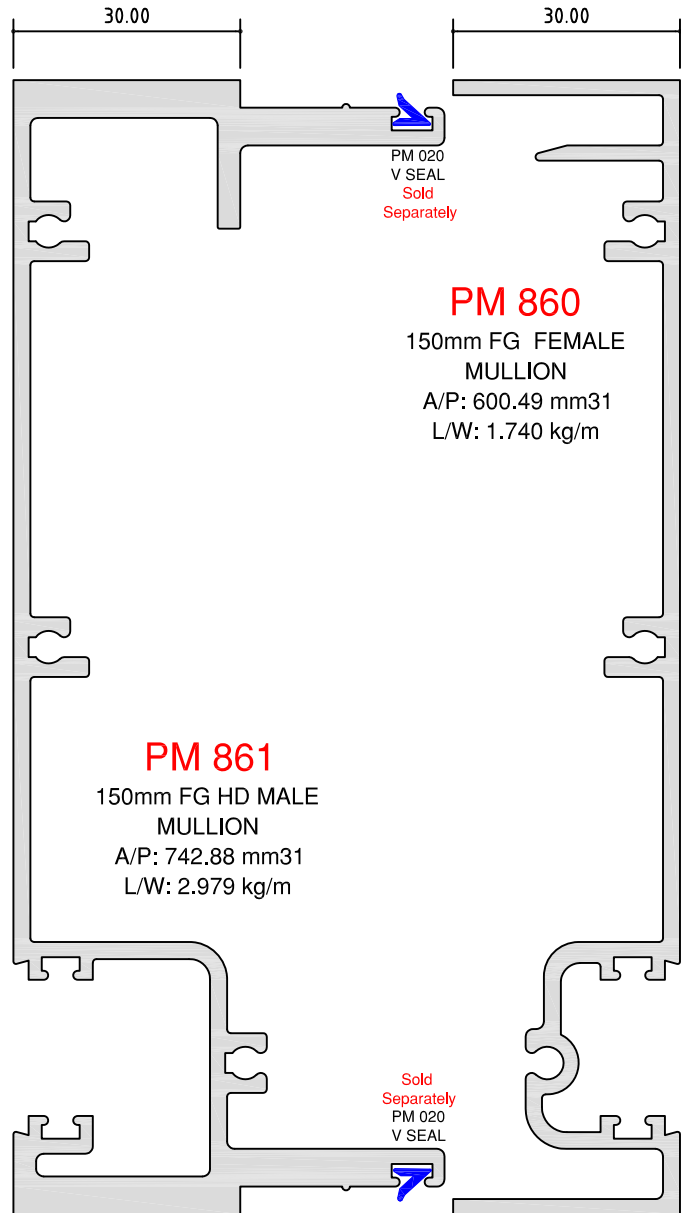
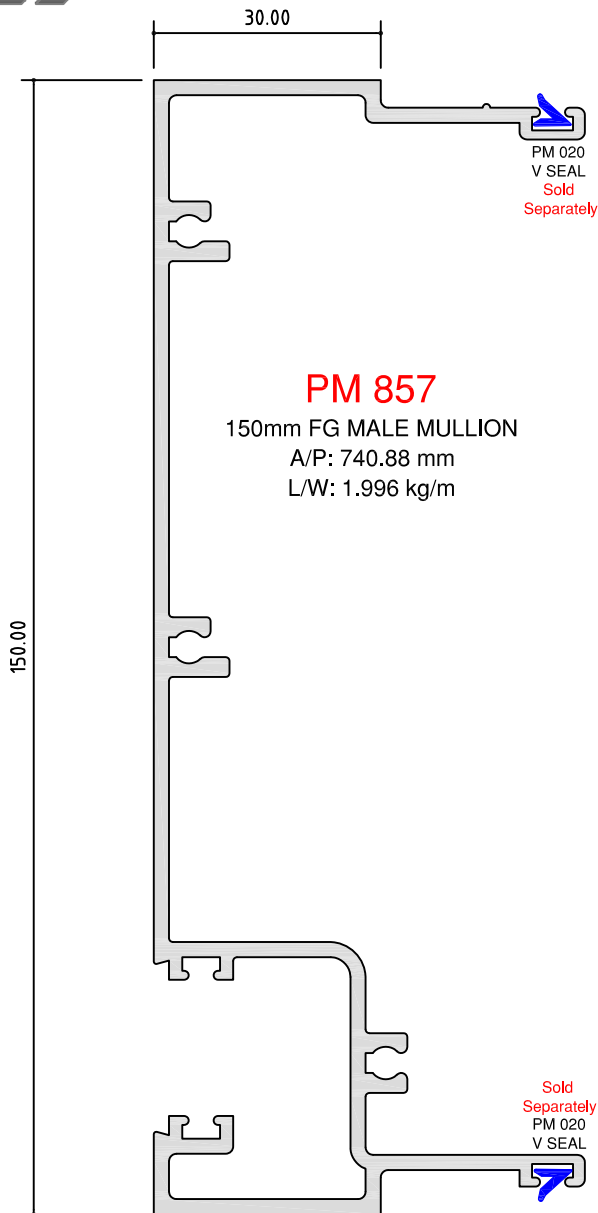

SCALE 1:1

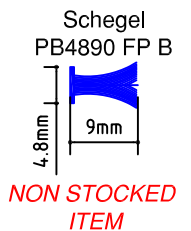
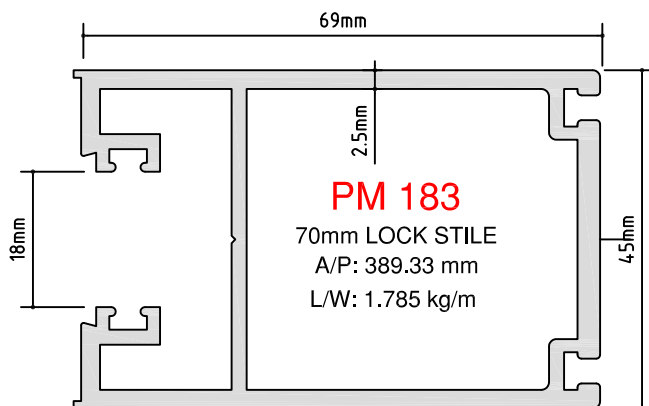
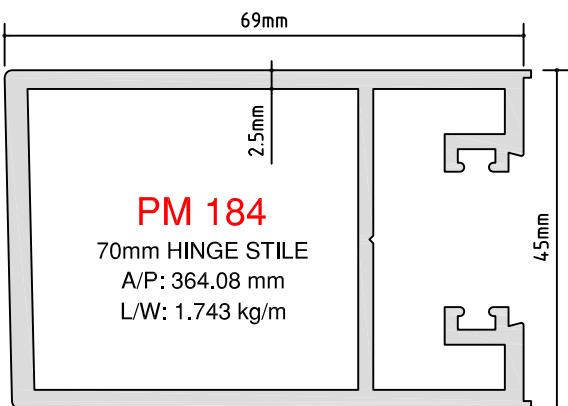
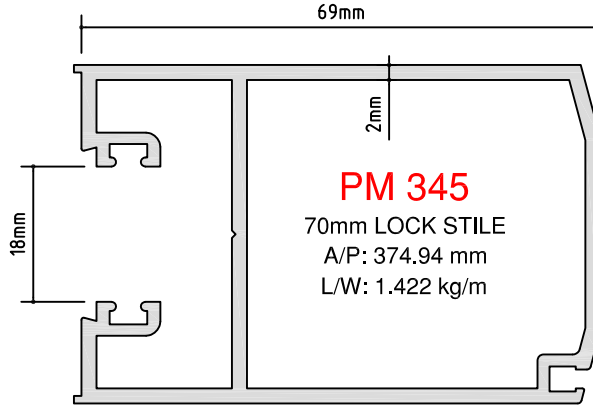
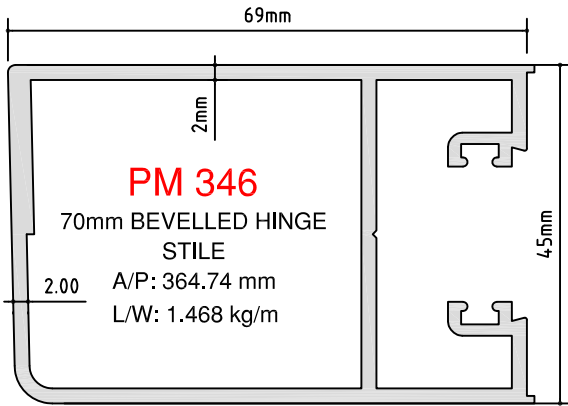
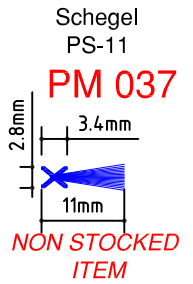
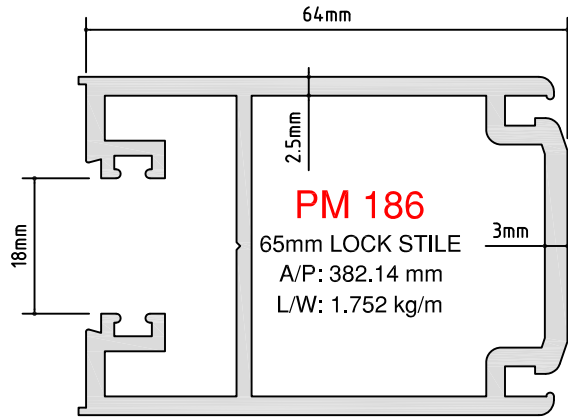
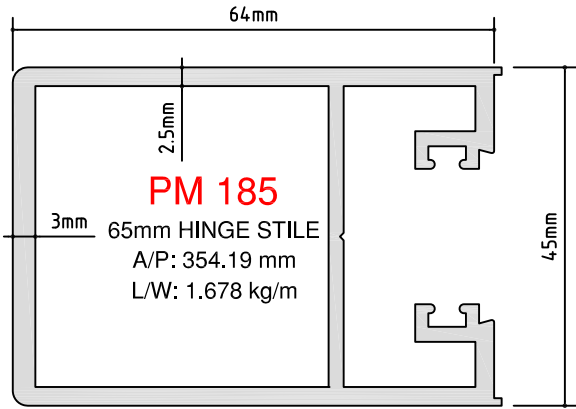

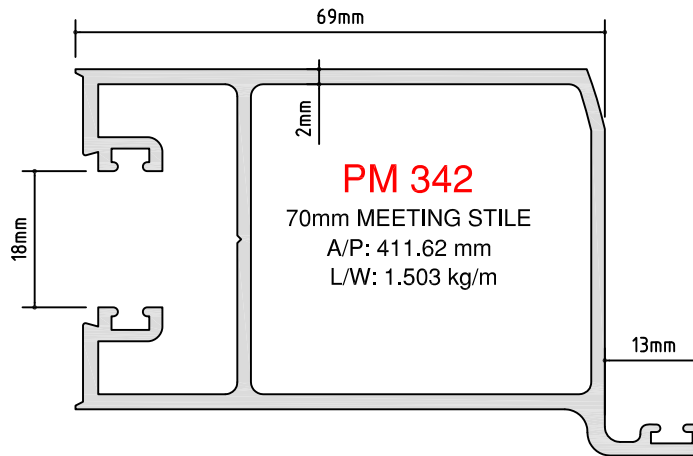
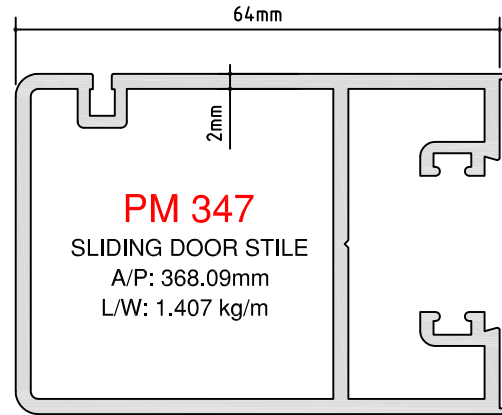
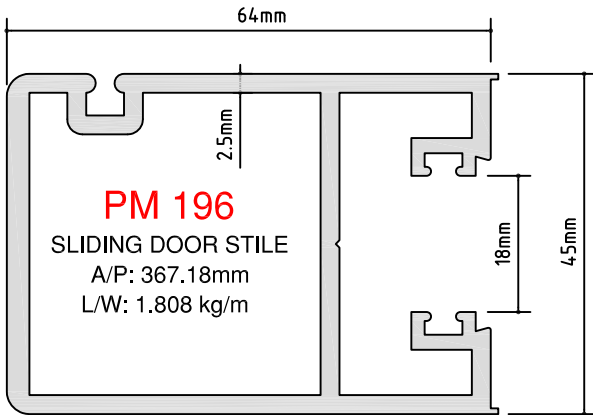

SCALE 1:1

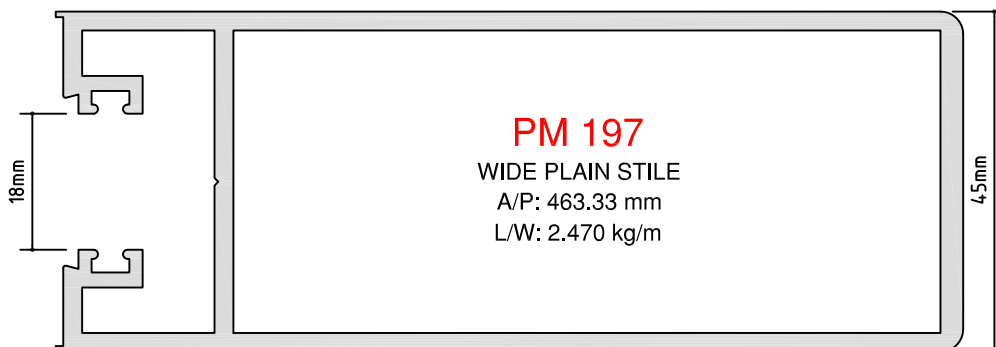
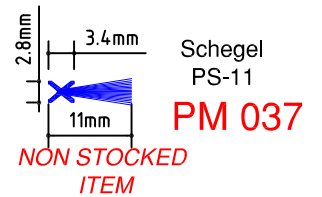
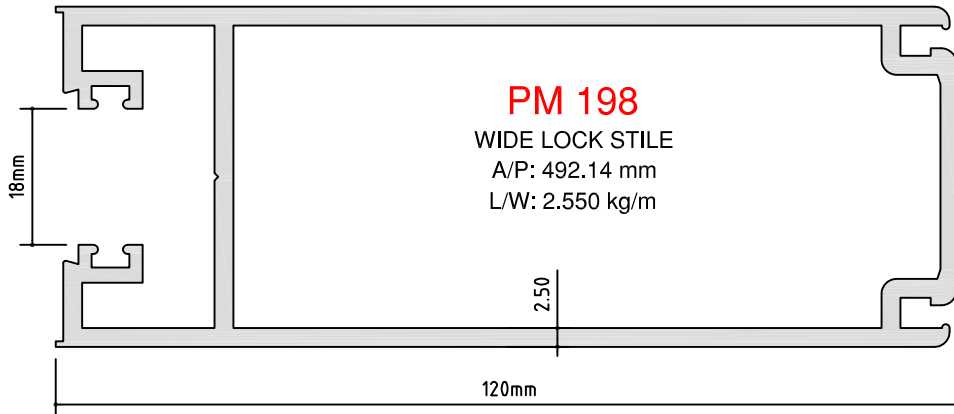

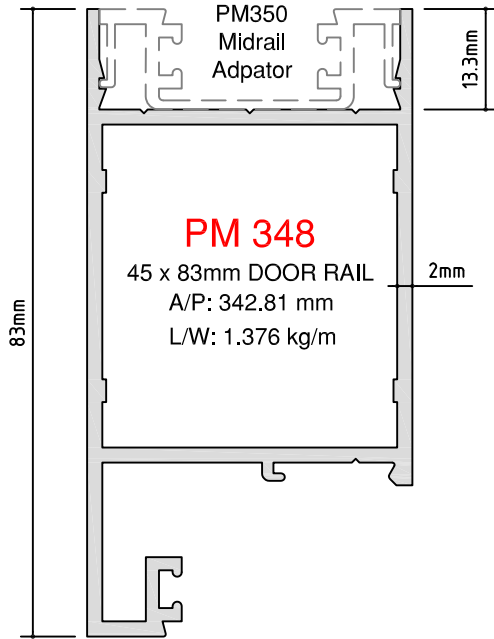

PM 348

45 x 83mm DOOR RAIL
A/P: 342.81 mm
L/W: 1.376 kg/m

PM 188

DOOR RAIL BEAD
A/P: 135.16 mm
L/W: 0.203 kg/m

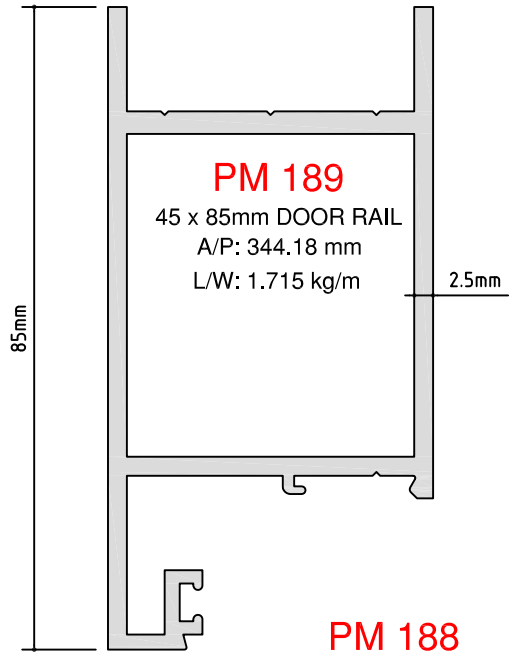

PM 189

45 x 85mm DOOR RAIL
A/P: 344.18 mm
L/W: 1.715 kg/m

PM 188

DOOR RAIL BEAD
A/P: 135.16 mm
L/W: 0.203 kg/m

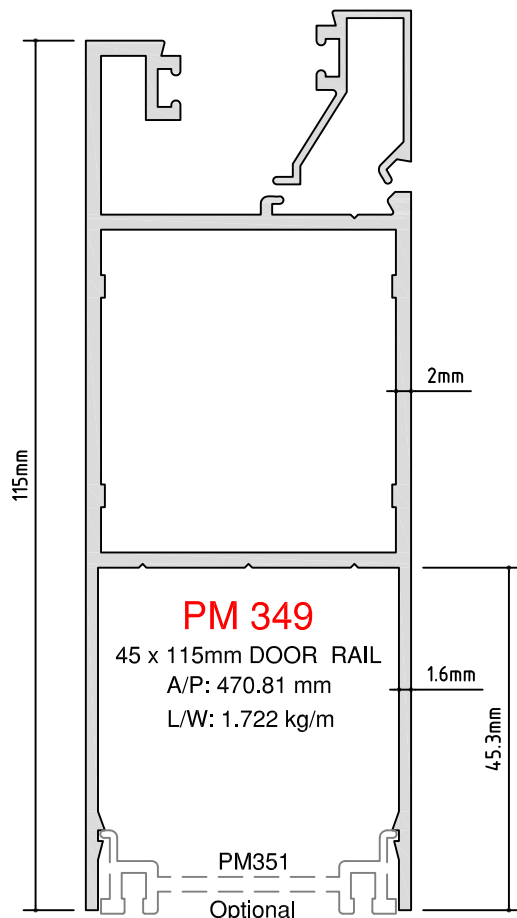

PM 349

45 x 115mm DOOR RAIL
A/P: 470.81 mm
L/W: 1.722 kg/m

PM351

Optional

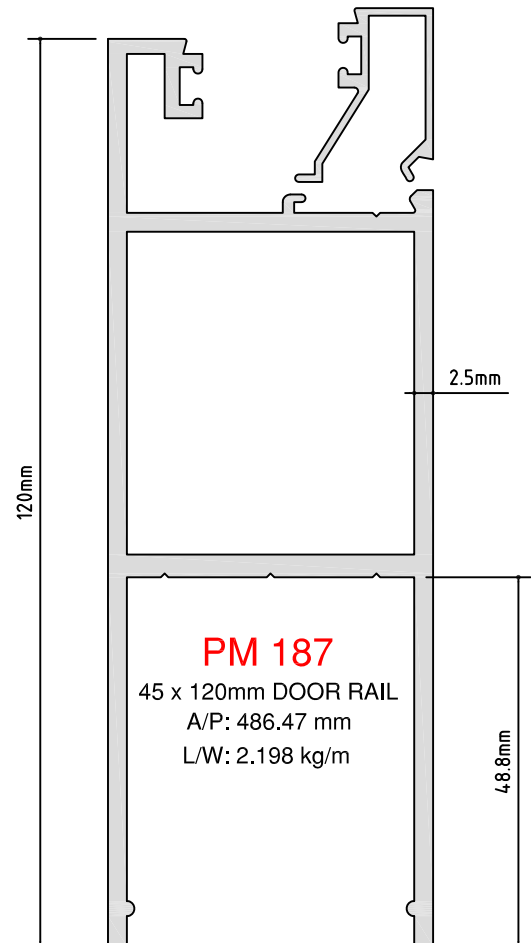

PM 187

45 x 120mm DOOR RAIL
A/P: 486.47 mm
L/W: 2.198 kg/m

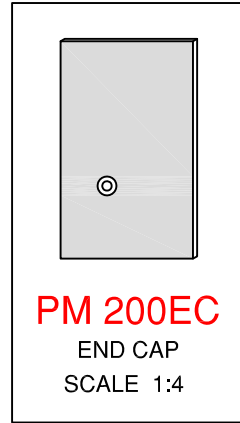
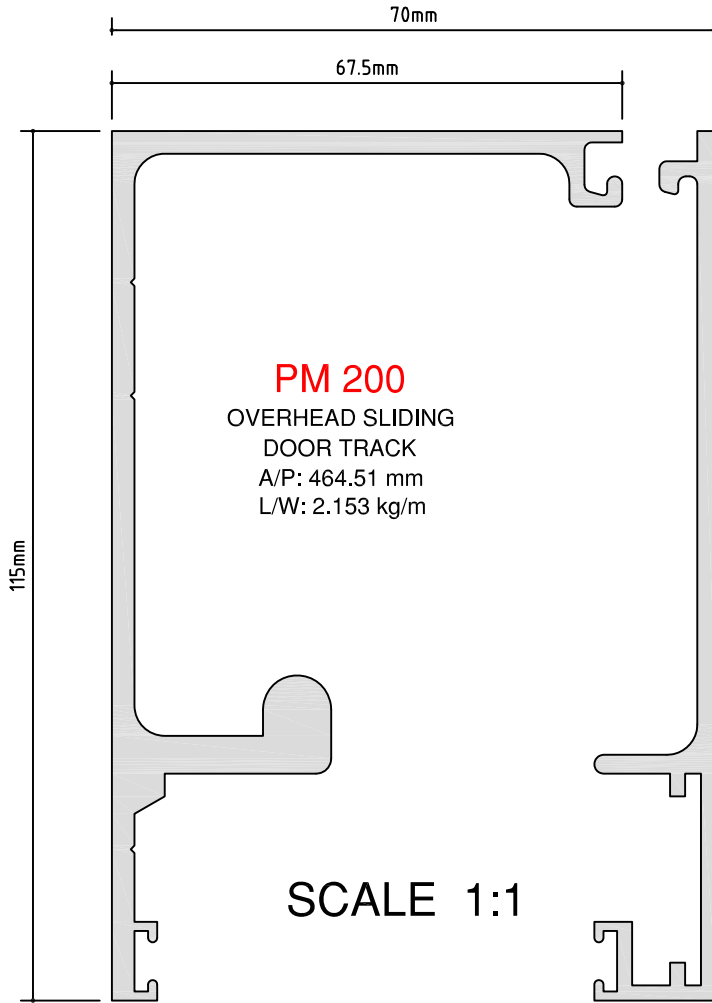

PM 201
PELMET
A/P: 338.94 mm
L/W: 1.067 kg/m

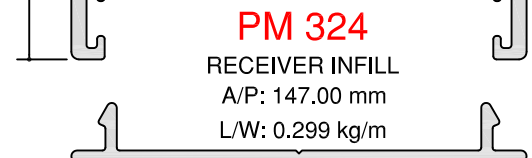
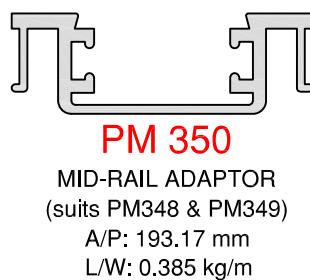
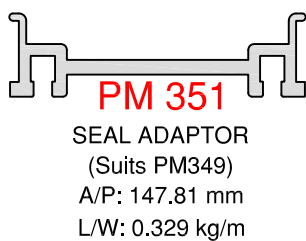
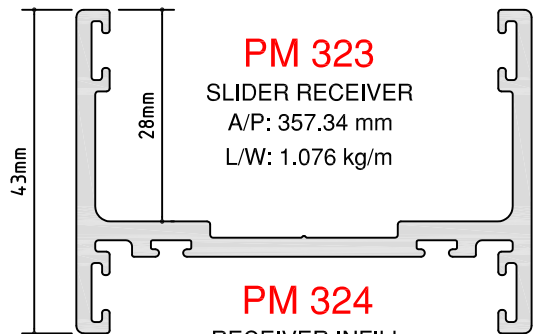
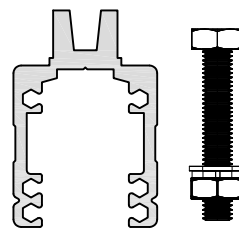
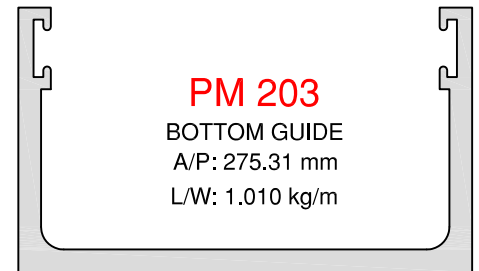
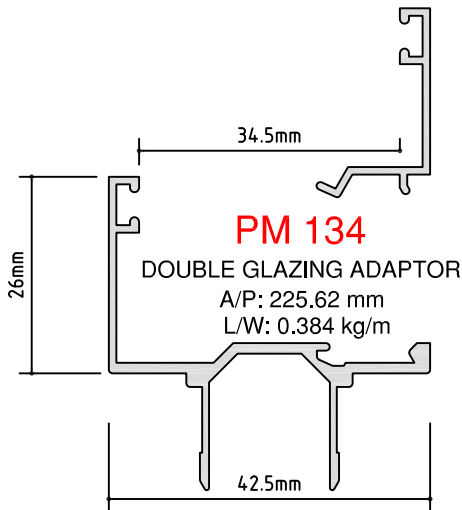
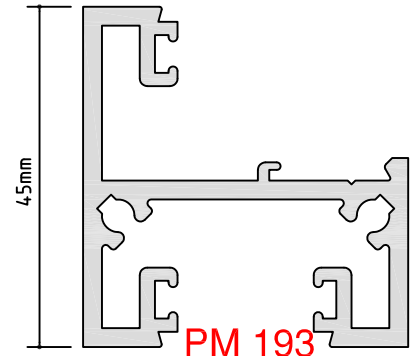

**COMMERCIAL DOORS
Single or Double Glazed**

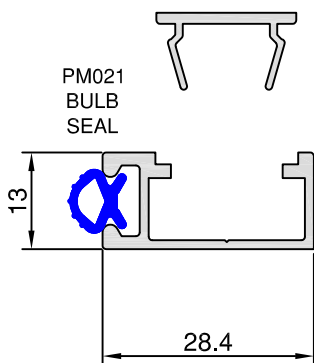
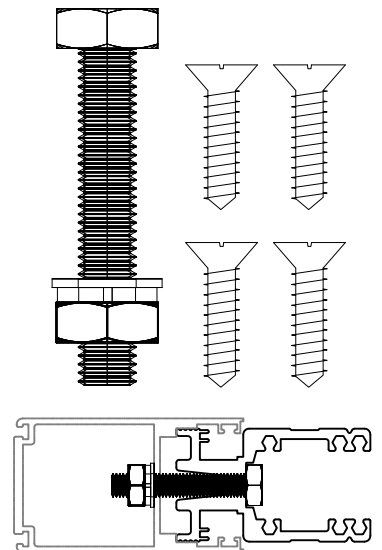
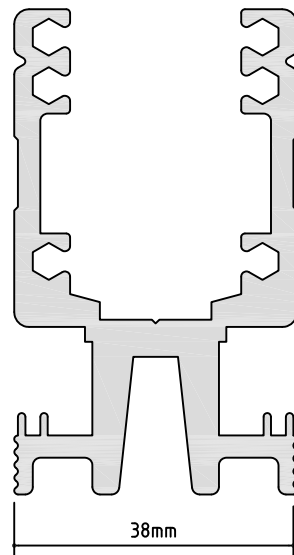
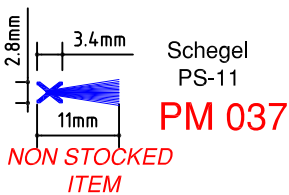
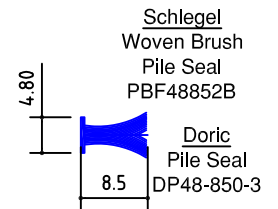
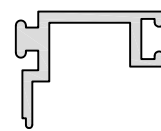
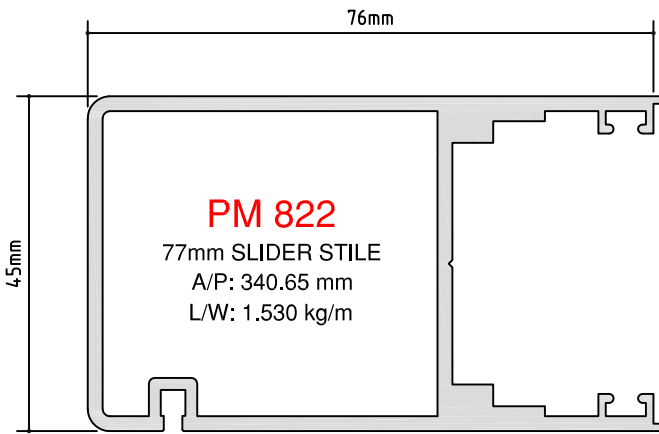
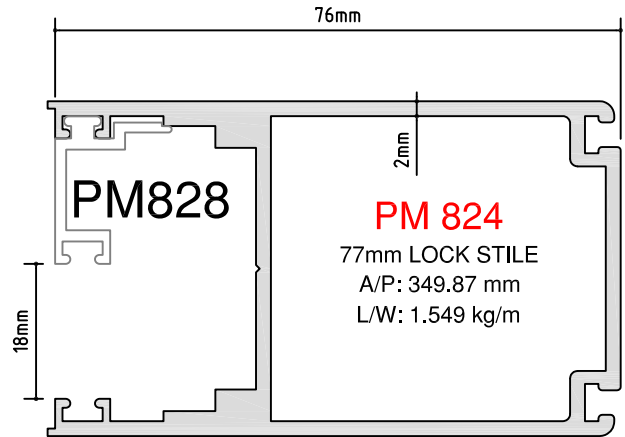
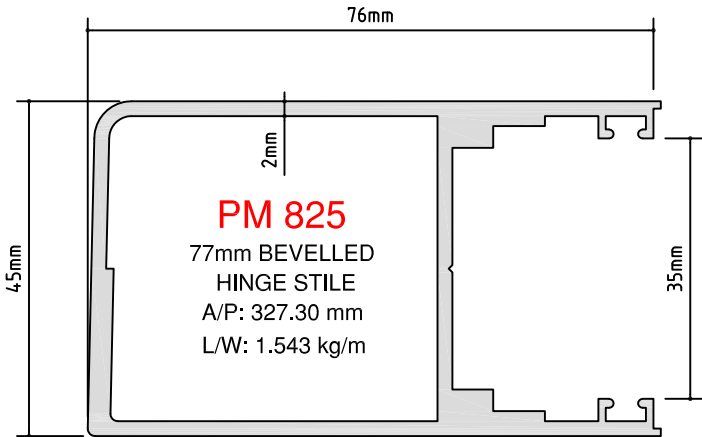

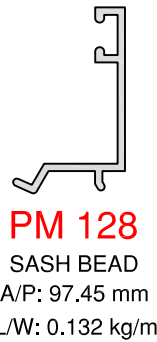
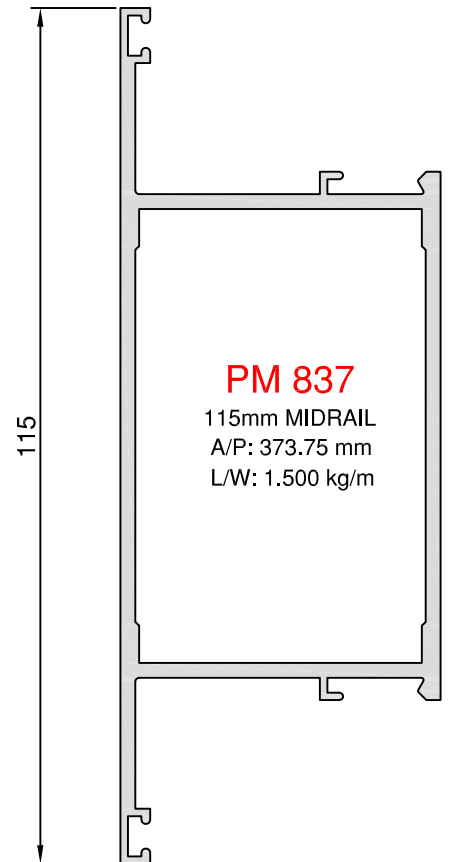
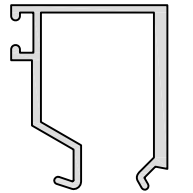
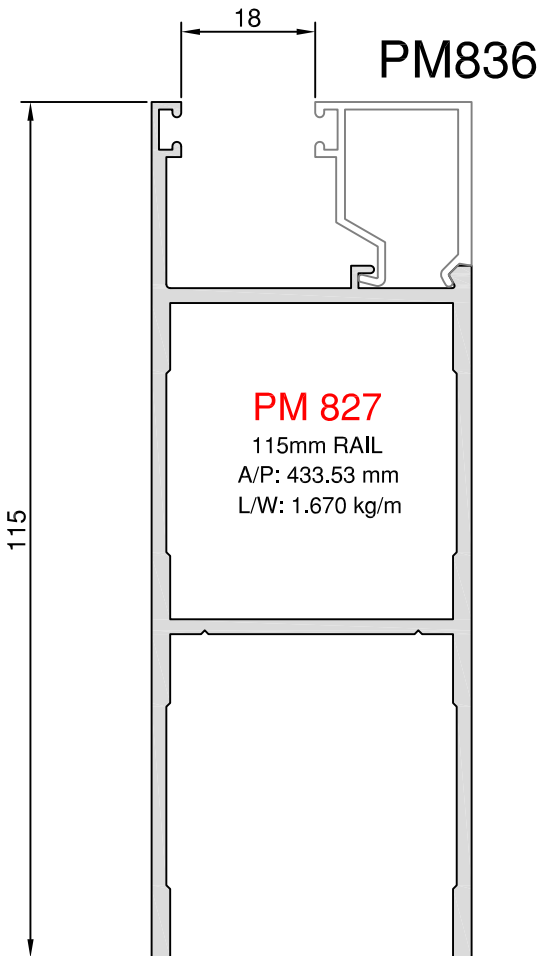
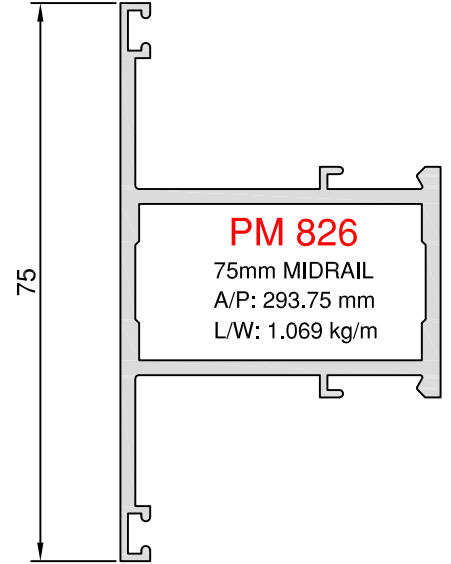
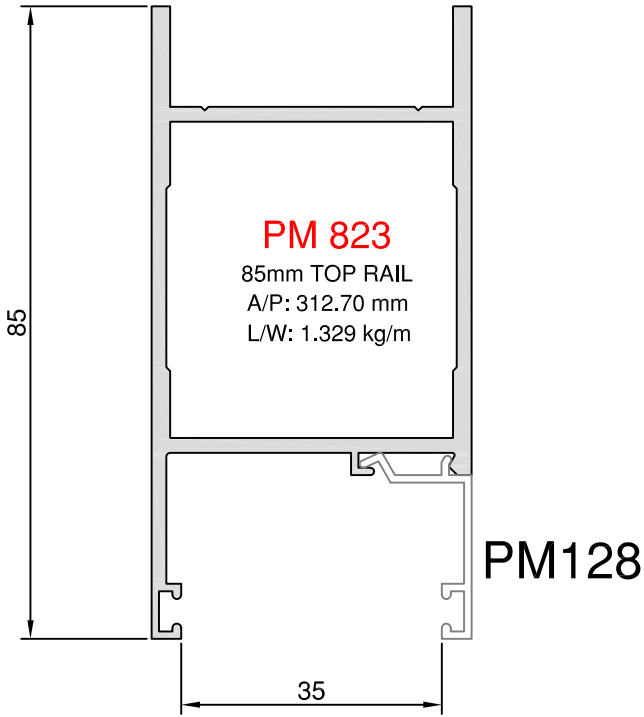

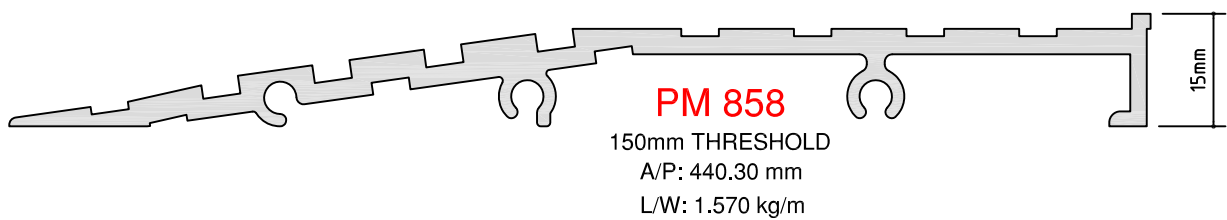
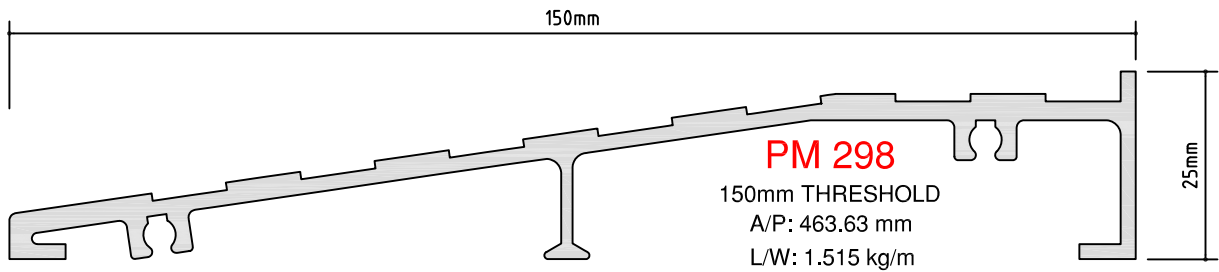
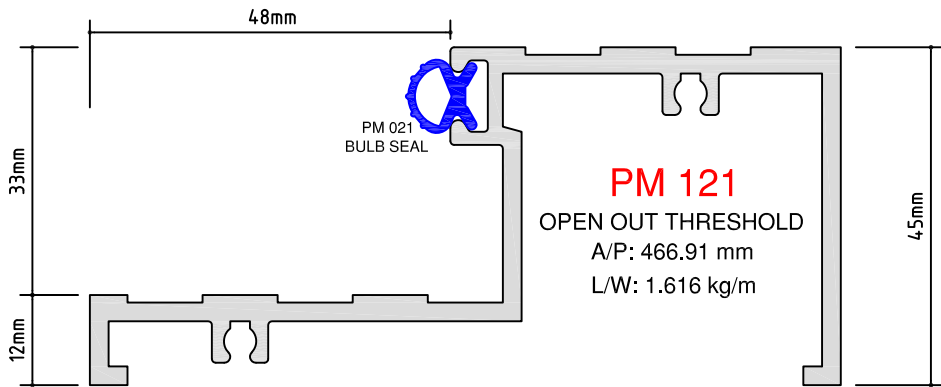
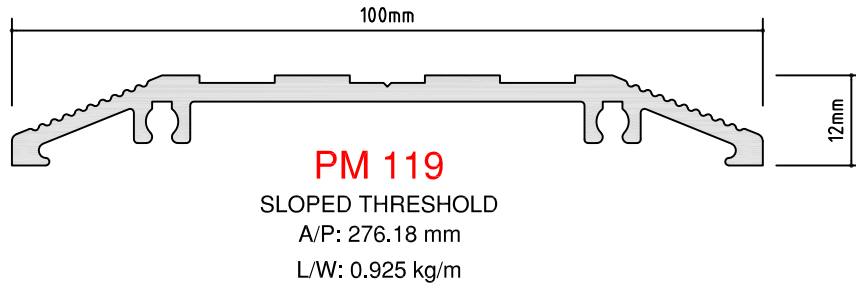
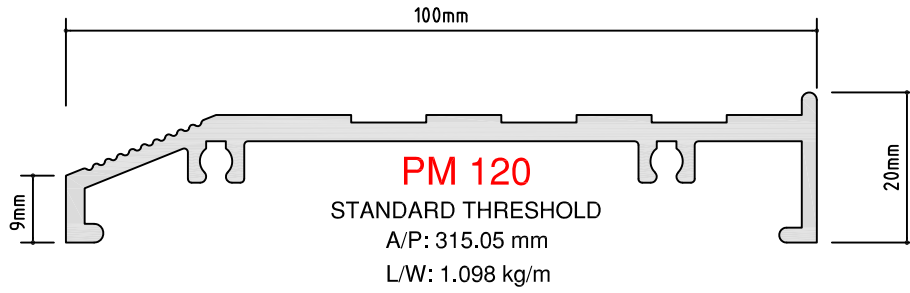



SCALE 1:1

PM 222

OVERLAP SASH HINGE
A/P: 214.94 mm
L/W: 0.683 kg/m

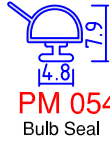
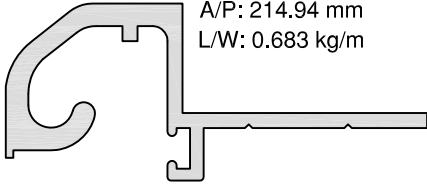

PM 054
Bulb Seal

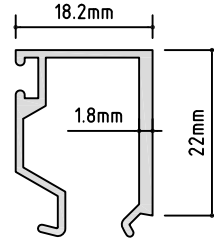

PM 129

SASH BEAD
A/P: 157.84 mm
L/W: 0.271 kg/m

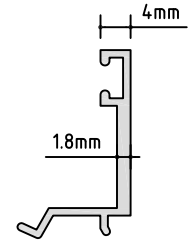

PM 128

SASH BEAD
A/P: 97.45 mm
L/W: 0.132 kg/m

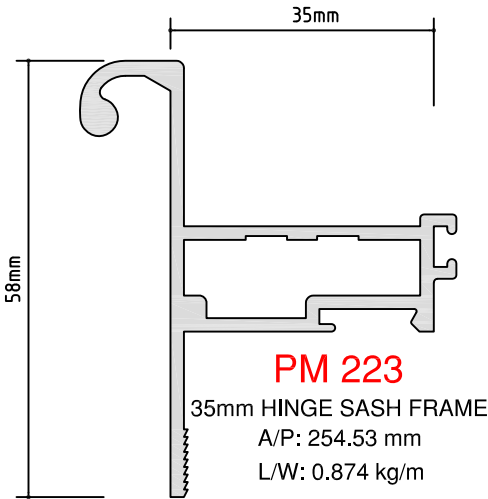

PM 223

35mm HINGE SASH FRAME
A/P: 254.53 mm
L/W: 0.874 kg/m

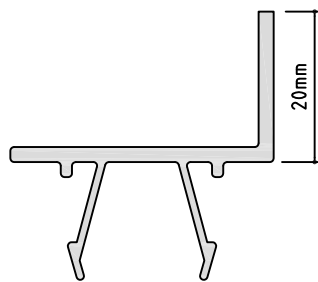

PM 126

35mm SASH ADAPTOR
(Fits 18mm Center Pocket)
A/P: 180.03 mm
L/W: 0.394 kg/m

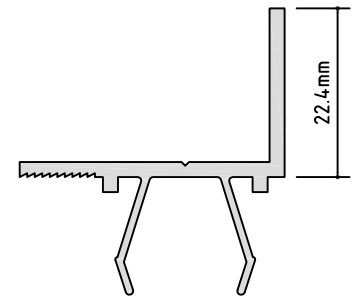

PM 229

35mm FRONT POCKET
OVERLAP SASH ADAPTOR
(Fits 18mm Pocket)
A/P: 268.50 mm
L/W: 0.922 kg/m

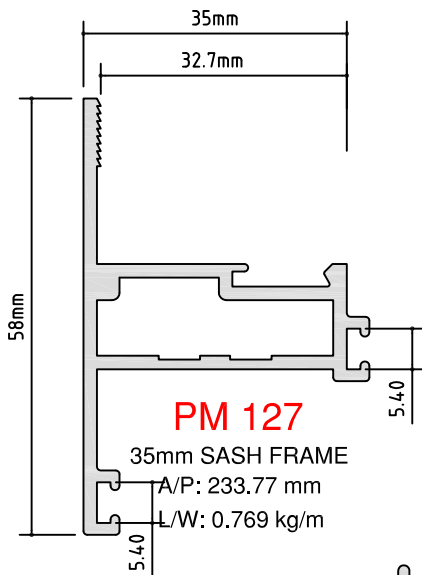

PM 127

35mm SASH FRAME
A/P: 233.77 mm
L/W: 0.769 kg/m

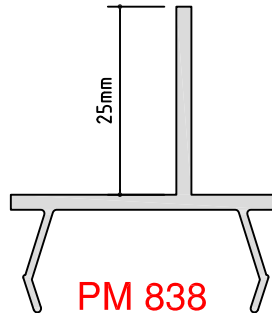

PM 838

35mm SASH ADAPTOR
(Suits 8000 Series Frame)
A/P: 181.28 mm
L/W: 0.408 kg/m

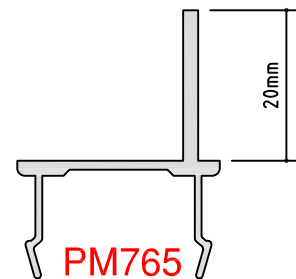

PM 765

AWNING SASH ADAPTOR
(Suits 2001 Series Frame)
A/P: 154.52 mm
L/W: 0.294 kg/m

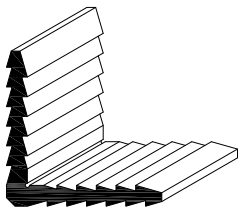

PM 051

UNIVERSAL AWNING SASH
CORNER STAKE

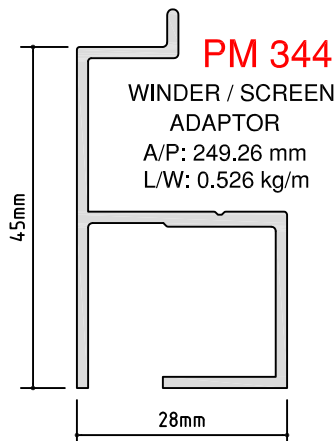

PM 344

WINDER / SCREEN
ADAPTOR
A/P: 249.26 mm
L/W: 0.526 kg/m

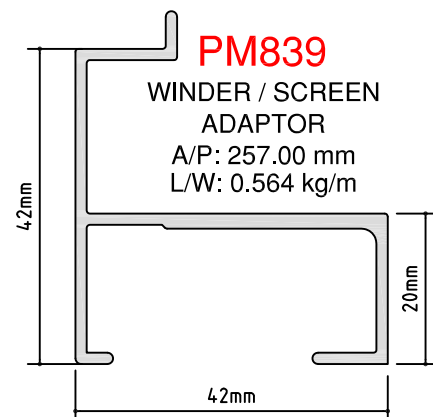

PM 839

WINDER / SCREEN
ADAPTOR
A/P: 257.00 mm
L/W: 0.564 kg/m

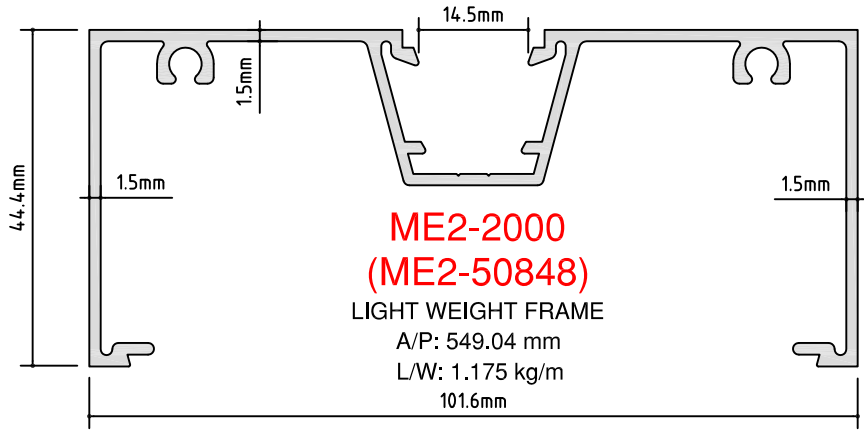

SCALE 1:1

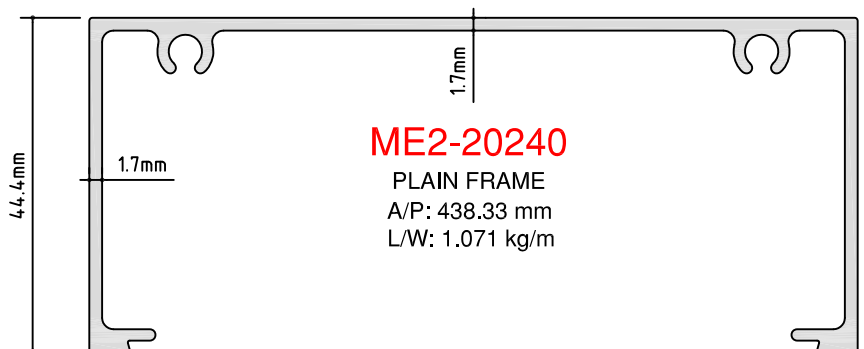
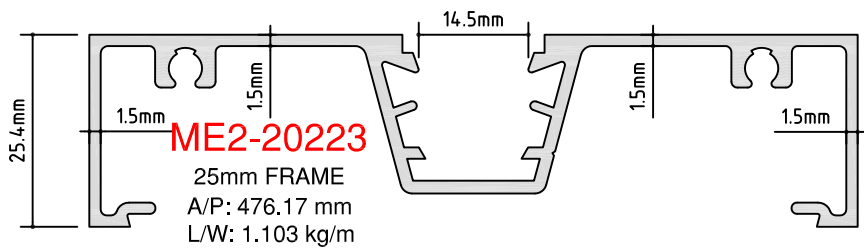
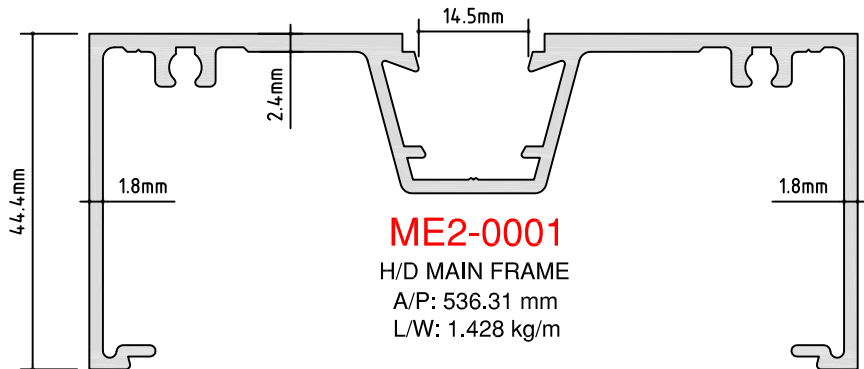
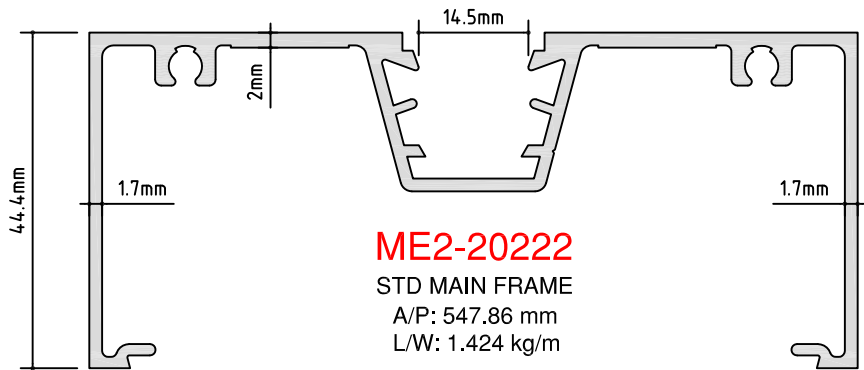

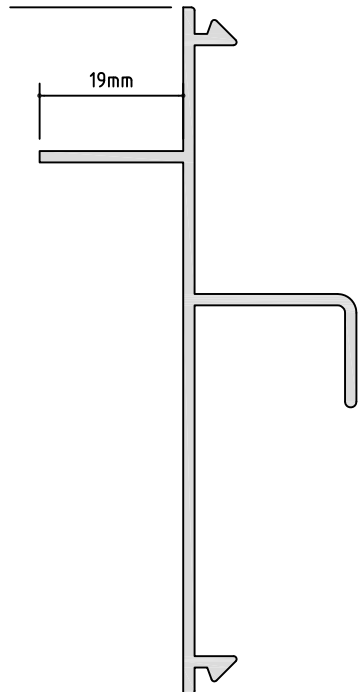
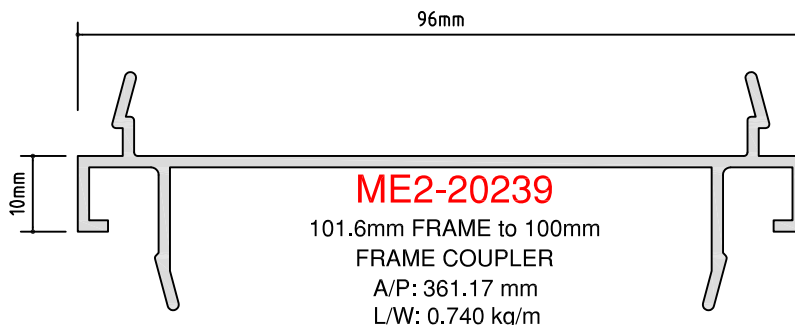
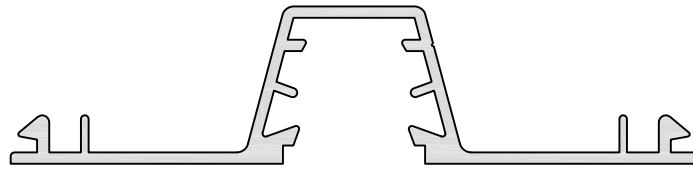
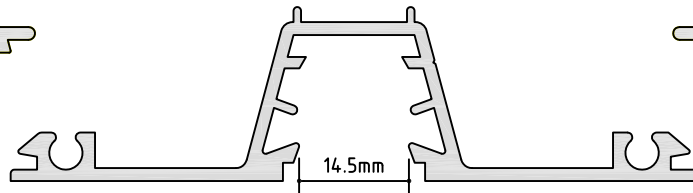
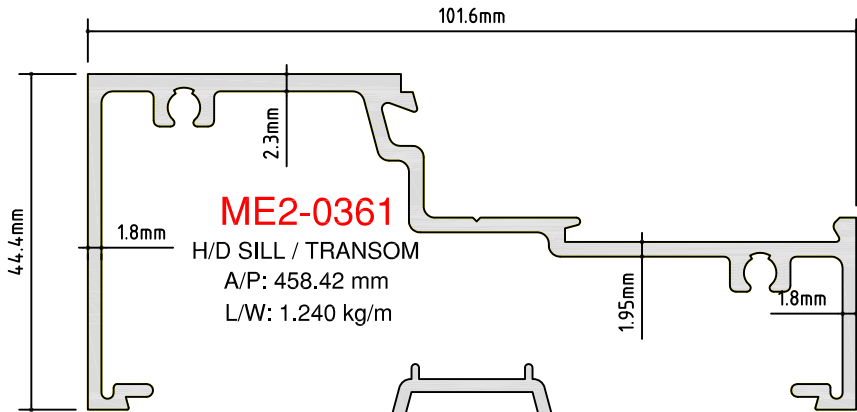
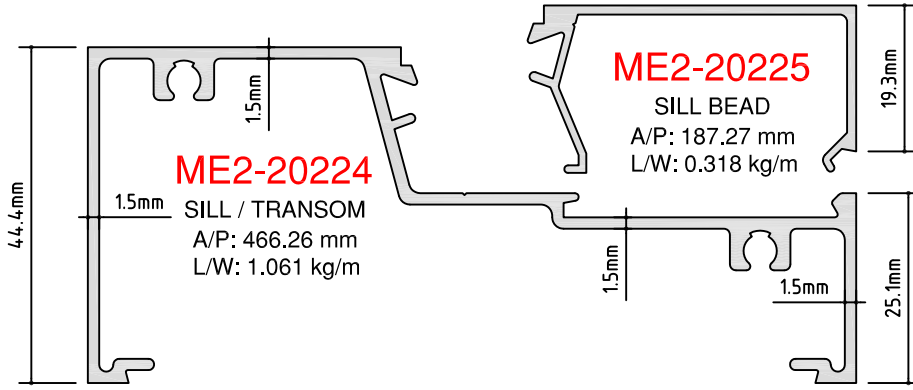

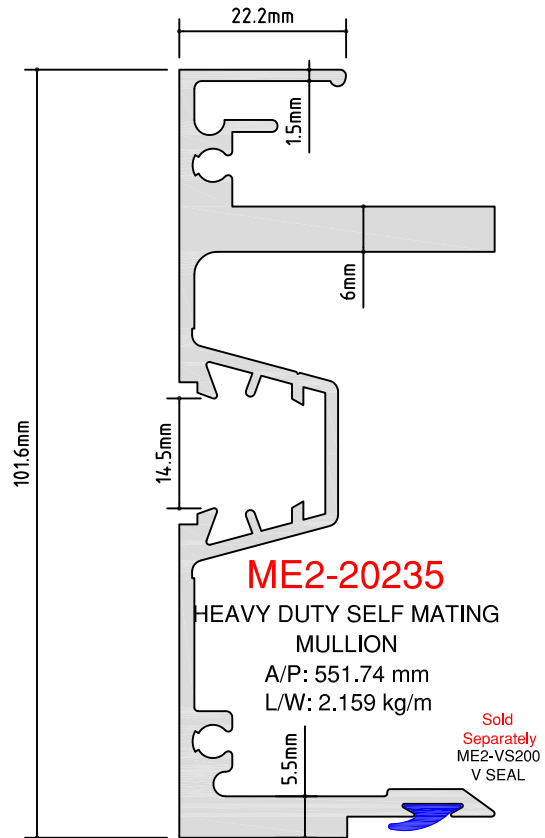
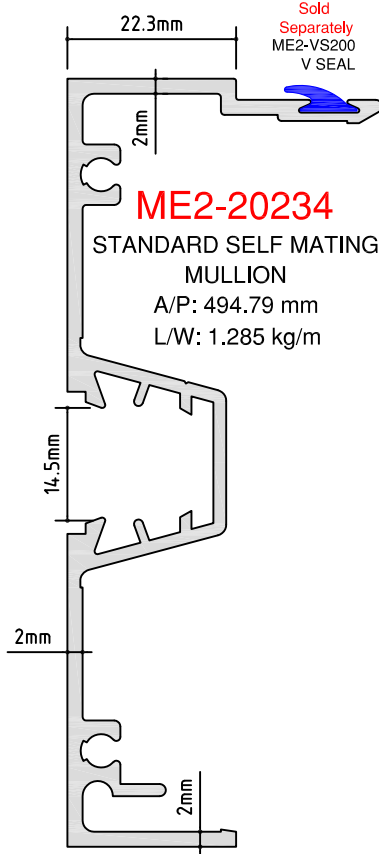

SCALE 1:1

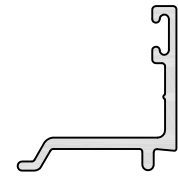
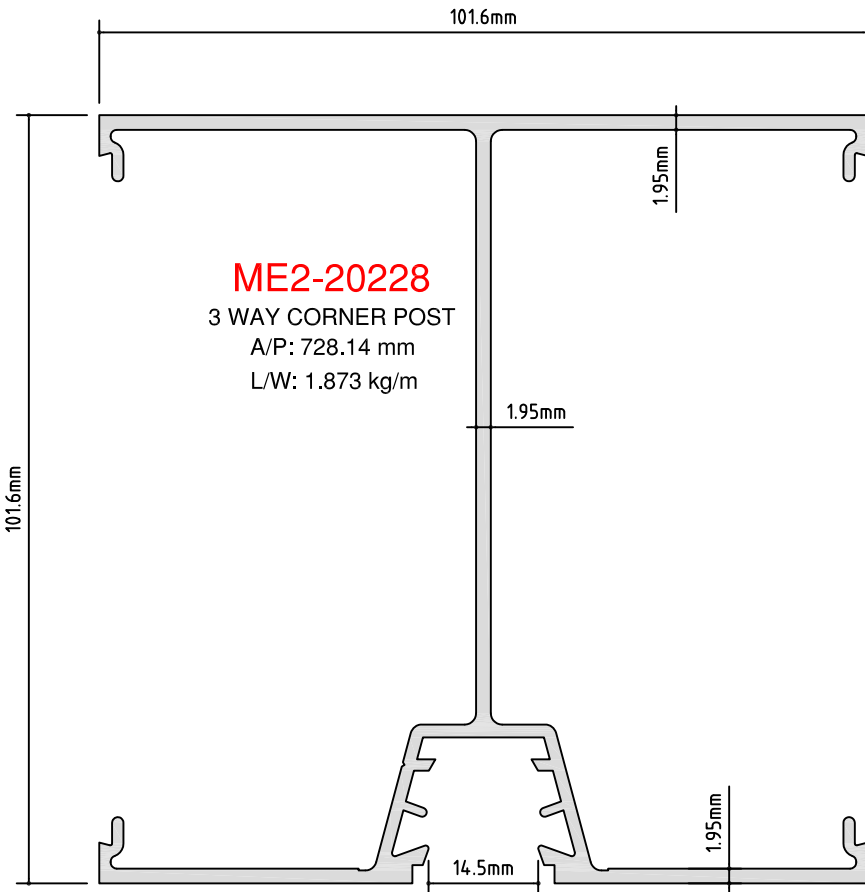

PM 123
CHANNEL BEAD
A/P: 102.97 mm
L/W: 0.262 kg/m

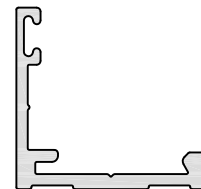

PM 122
CHANNEL BASE
A/P: 149.74 mm
L/W: 0.388 kg/m

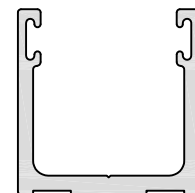

PM 124
CHANNEL
A/P: 183.47 mm
L/W: 0.480 kg/m

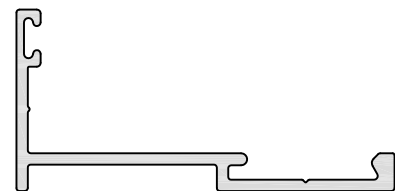

PM 322
DG CHANNEL BASE
A/P: 174.78 mm
L/W: 0.352 kg/m

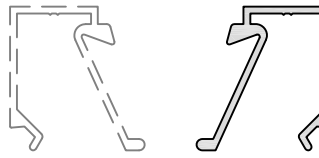

ME2-3652
COC TRANSOM
GLAZING BEAD
A/P: 116.39 mm
L/W: 0.159 kg/m

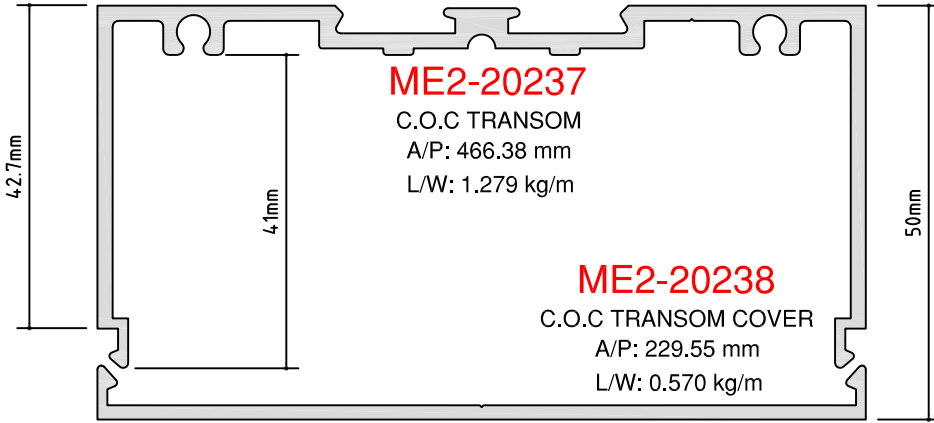

ME2-20237
C.O.C TRANSOM
A/P: 466.38 mm
L/W: 1.279 kg/m

ME2-20238
C.O.C TRANSOM COVER
A/P: 229.55 mm
L/W: 0.570 kg/m

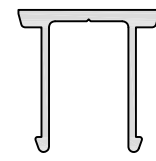

ME2-20230
POCKET FILLER
A/P: 108.95 mm
L/W: 0.186 kg/m

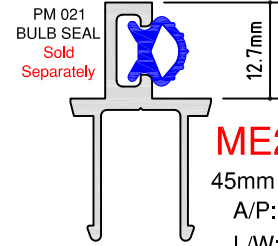

ME2-20232
45mm DOOR STOP
A/P: 148.12 mm
L/W: 0.292 kg/m

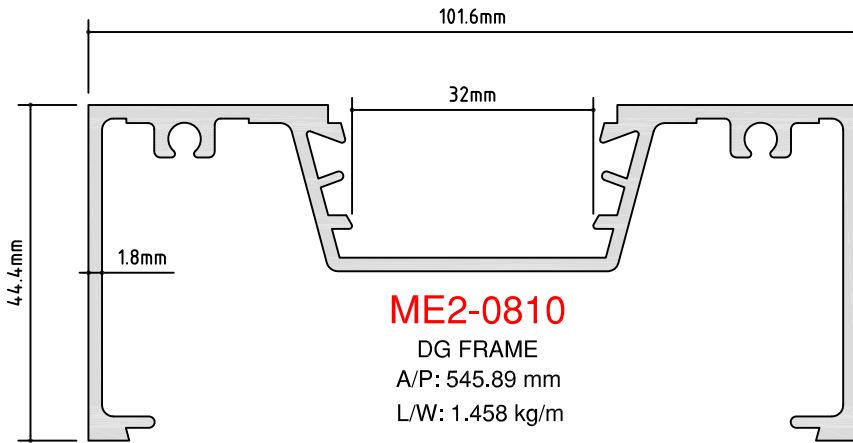

ME2-0810
DG FRAME
A/P: 545.89 mm
L/W: 1.458 kg/m

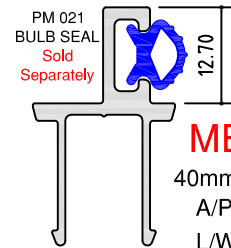

ME2-4899
40mm DOOR STOP
A/P: 146.52 mm
L/W: 0.293 kg/m

ME2-0813
DG BEAD
A/P: 159.91 mm
L/W: 0.270 kg/m

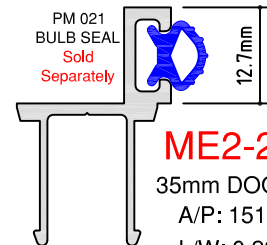

ME2-20231
35mm DOOR STOP
A/P: 151.89 mm
L/W: 0.293 kg/m

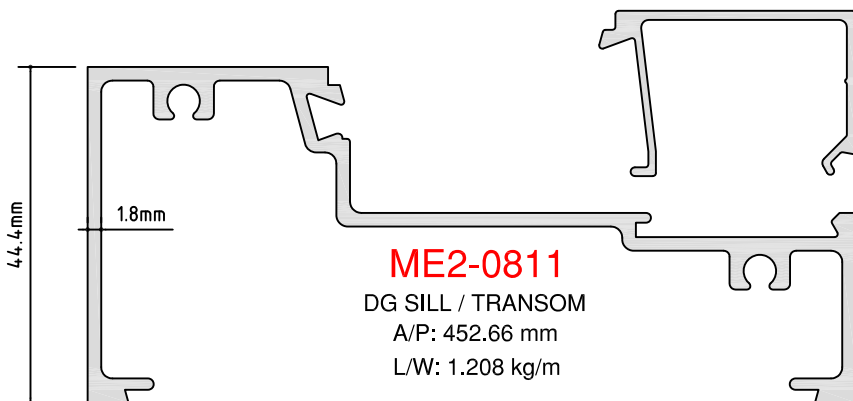

ME2-0811
DG SILL / TRANSOM
A/P: 452.66 mm
L/W: 1.208 kg/m

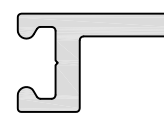

PM 191
PLANT ON DOOR STOP
A/P: 78.69 mm
L/W: 0.275 kg/m

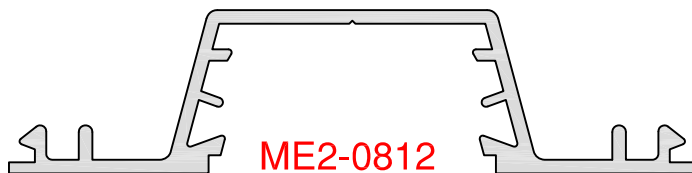

ME2-0812
DG GLAZING ADAPTOR
A/P: 327.62 mm
L/W: 0.815 kg/m

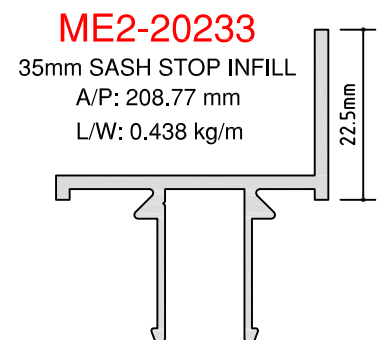

ME2-20233
35mm SASH STOP INFILL
A/P: 208.77 mm
L/W: 0.438 kg/m

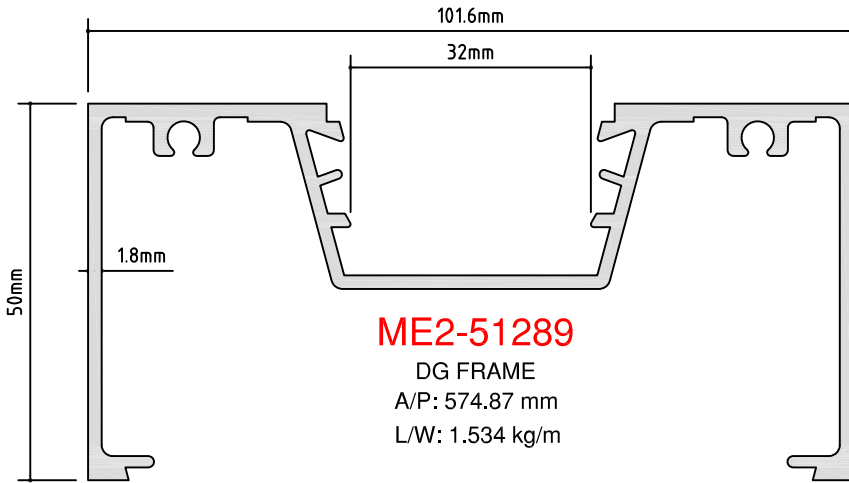

ME2-51289
DG FRAME
A/P: 574.87 mm
L/W: 1.534 kg/m

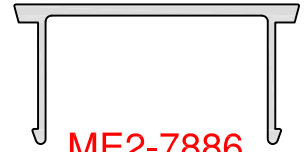

ME2-7886
DG POCKET INFILL
A/P: 144.57 mm
L/W: 0.277 kg/m

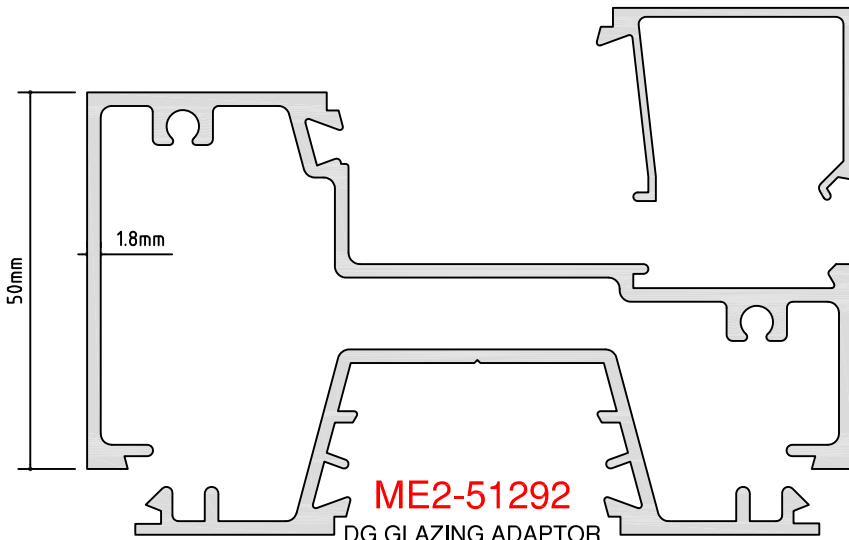

ME2-51291
DG BEAD
A/P: 175.51 mm
L/W: 0.293 kg/m

ME2-51290
DG SILL / TRANSOM
A/P: 475.26 mm
L/W: 1.268 kg/m

ME2-51292
DG GLAZING ADAPTOR
A/P: 336.74 mm
L/W: 0.838 kg/m

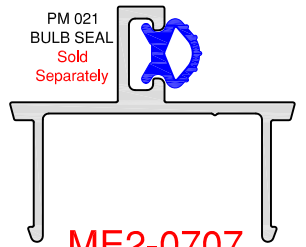

ME2-0707
45mm DOOR STOP
A/P: 183.61 mm
L/W: 0.386 kg/m

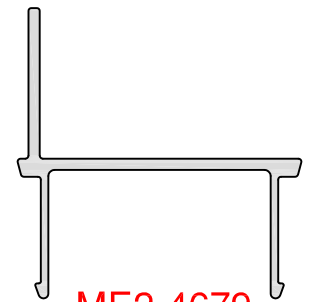

ME2-4679
35mm SASH ADAPTOR
A/P: 184.13 mm
L/W: 0.343 kg/m

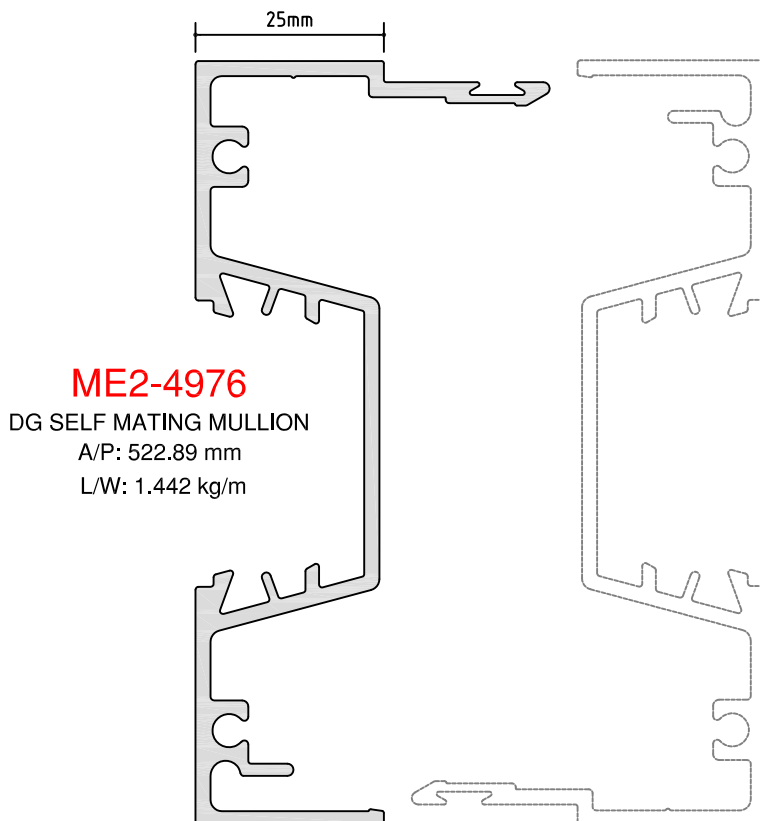

ME2-4976
DG SELF MATING MULLION
A/P: 522.89 mm
L/W: 1.442 kg/m

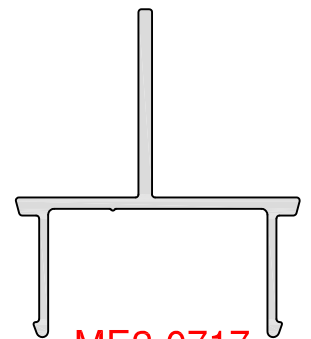

ME2-0717
50mm SASH ADAPTOR
A/P: 194.02 mm
L/W: 0.402 kg/m

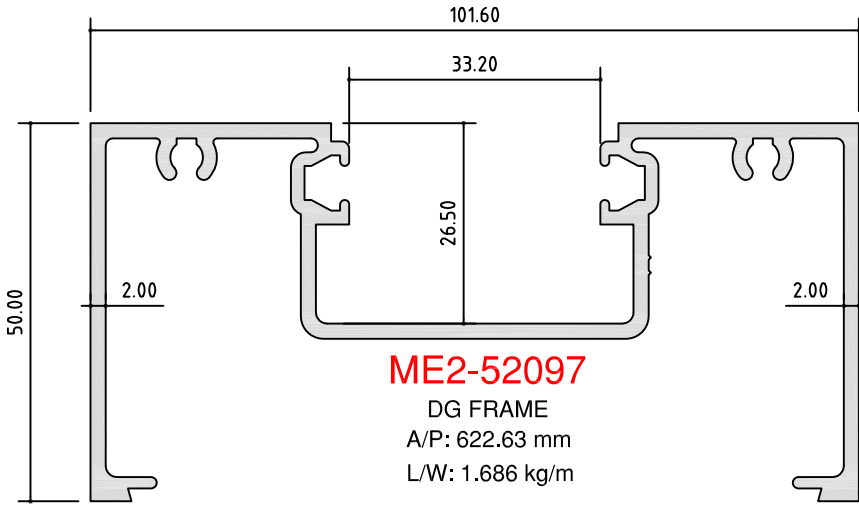

ME2-52097

DG FRAME
A/P: 622.63 mm
L/W: 1.686 kg/m

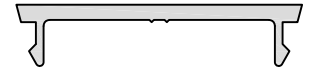

ME2-52103

DG POCKET FILLER
A/P: 102.75 mm
L/W: 0.244 kg/m

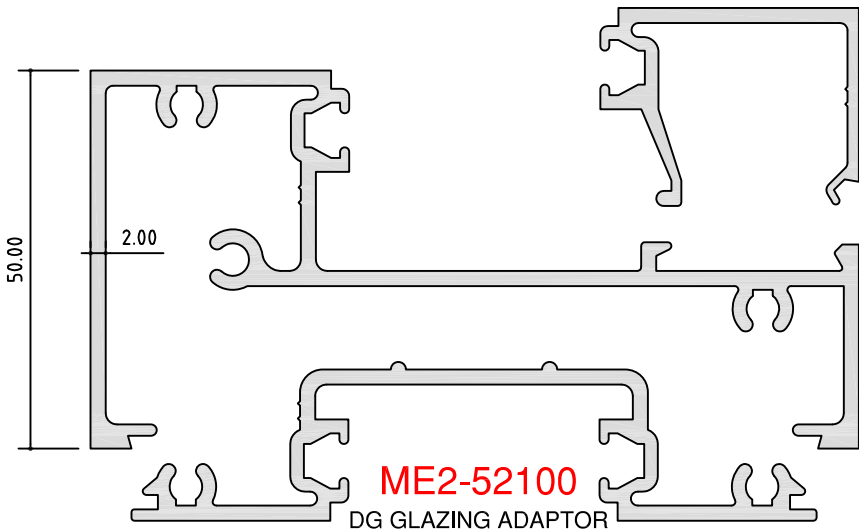

ME2-52099

DG BEAD
A/P: 194.31 mm
L/W: 0.463 kg/m

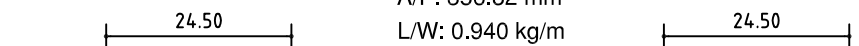

ME2-52100

DG GLAZING ADAPTOR
A/P: 356.82 mm
L/W: 0.940 kg/m

ME2-52098

DG SILL
A/P: 552.25 mm
L/W: 1.518 kg/m

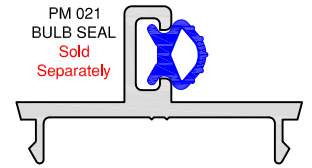

ME2-52104

DG 45mm DOOR STOP
A/P: 140.83 mm
L/W: 0.349 kg/m

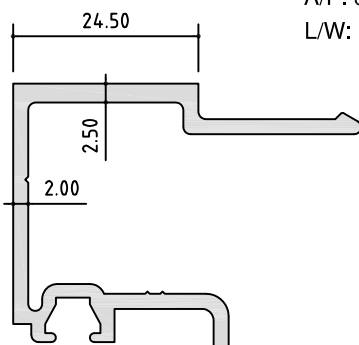

ME2-52101

DG MALE MULLION
A/P: 553.88 mm
L/W: 1.551 kg/m

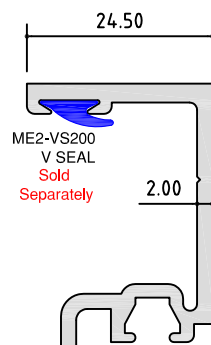

ME2-52102

DG FEMALE MULLION
A/P: 440.85 mm
L/W: 1.202 kg/m

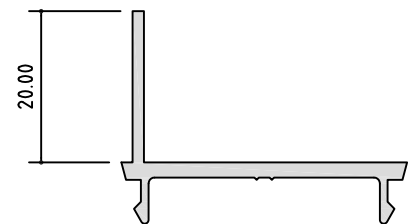

ME2-52105

DG 35mm AWNING SASH
ADAPTOR
A/P: 142.75 mm
L/W: 0.326 kg/m

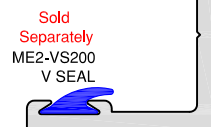
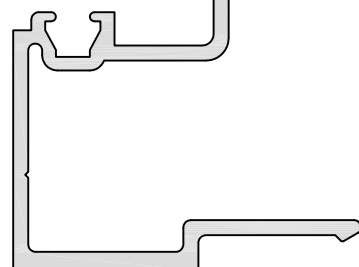

Sold

Separately
SCE52-22
Bulb Seal

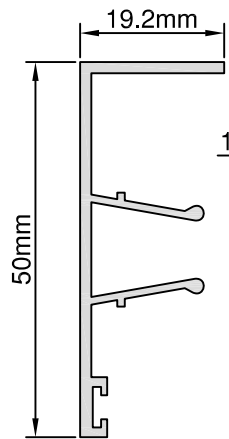

PM708

RETURN
SNAP COVER
A/P: 216.02 mm
L/W: 0.393 kg/m

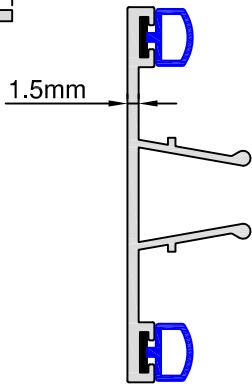

PM709

SNAP COVER
A/P: 191.85 mm
L/W: 0.342 kg/m

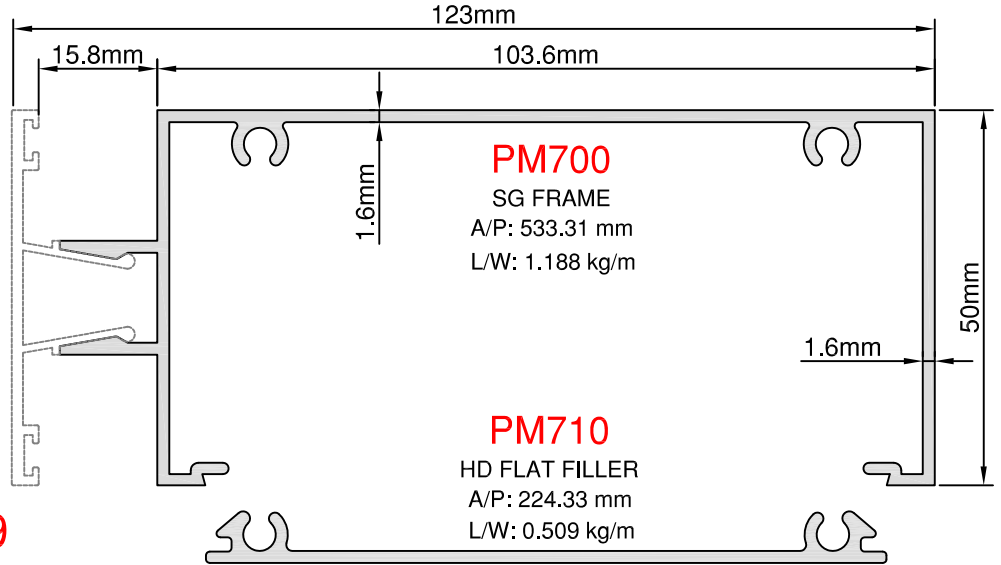

PM700

SG FRAME
A/P: 533.31 mm
L/W: 1.188 kg/m

PM710

HD FLAT FILLER
A/P: 224.33 mm
L/W: 0.509 kg/m

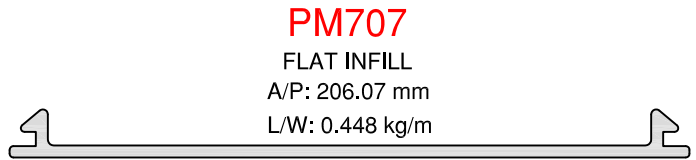

PM707

FLAT INFILL
A/P: 206.07 mm
L/W: 0.448 kg/m

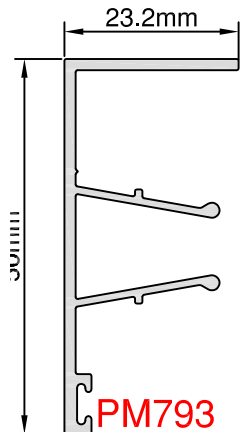

PM793

RETURN CAP
A/P: 237.63 mm
L/W: 0.433 kg/m

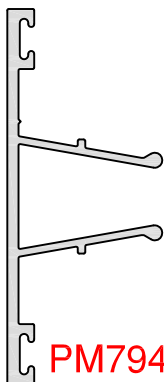

PM794

SNAP ON CAP
A/P: 205.49 mm
L/W: 0.367 kg/m

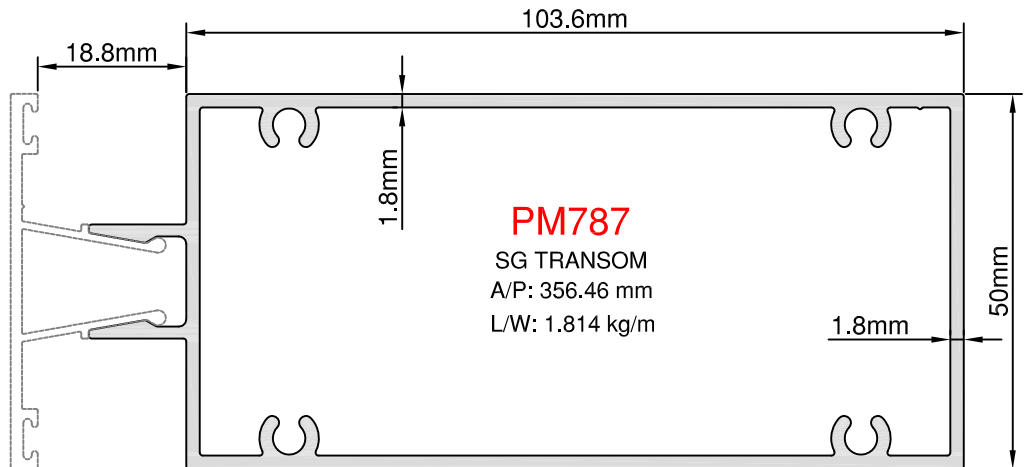

PM787

SG TRANSOM
A/P: 356.46 mm
L/W: 1.814 kg/m

**DETAIL
SCALE 1:1**

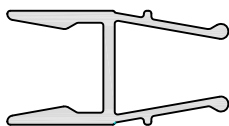

PM797

DG ADAPTOR
A/P: 147.09 mm
L/W: 0.280 kg/m

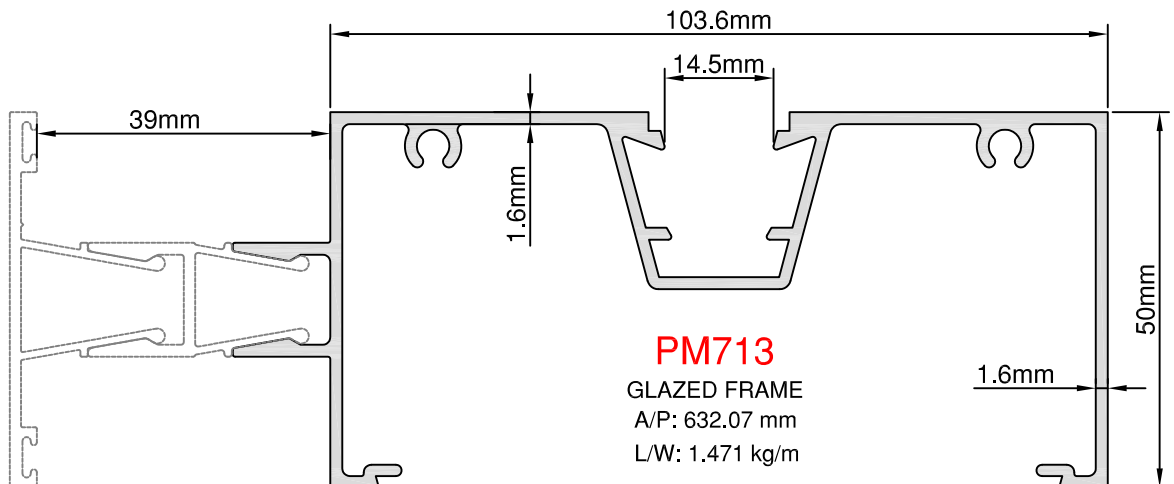

PM713

GLAZED FRAME
A/P: 632.07 mm
L/W: 1.471 kg/m

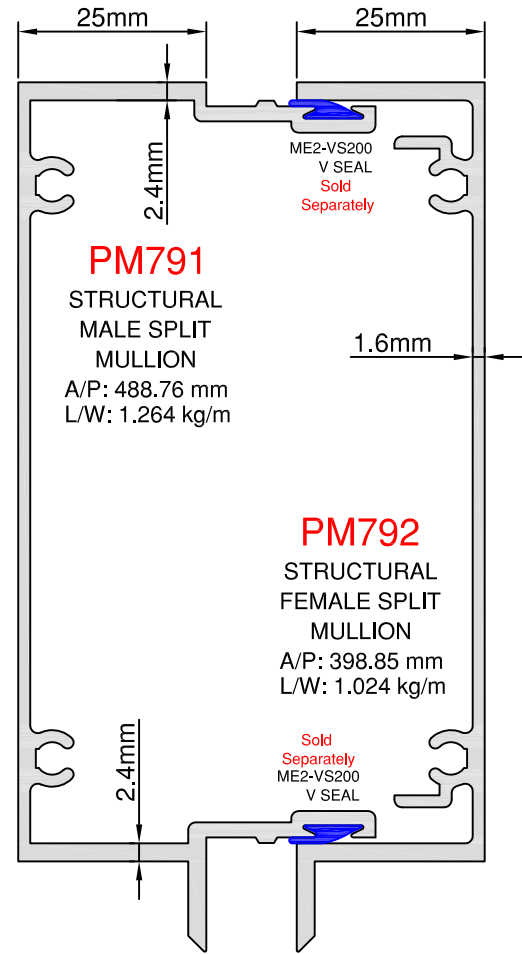
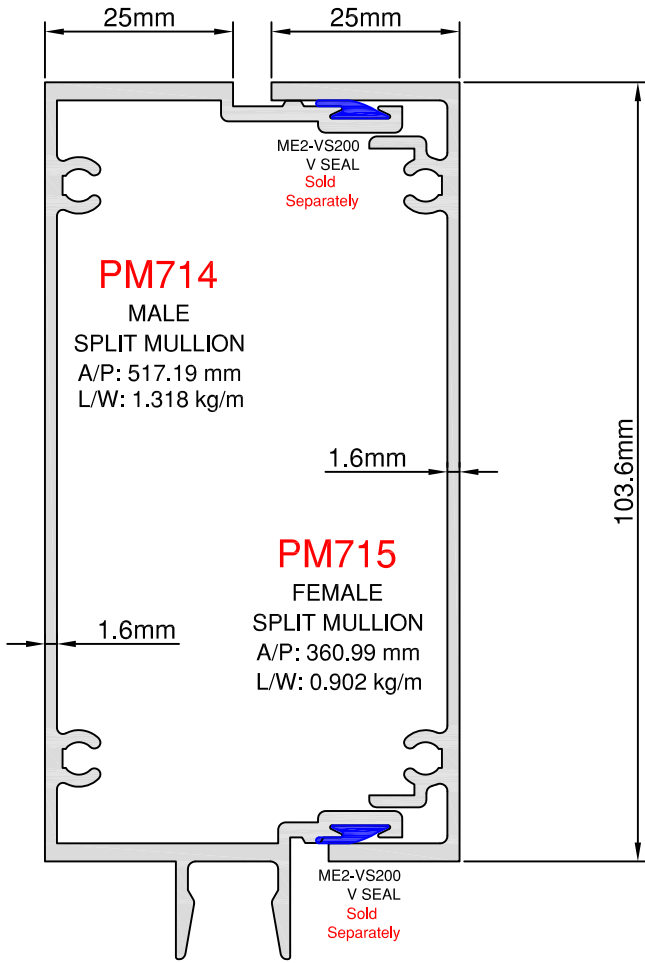

**DETAIL
SCALE 1:1**

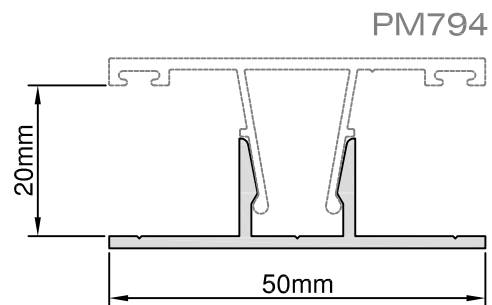
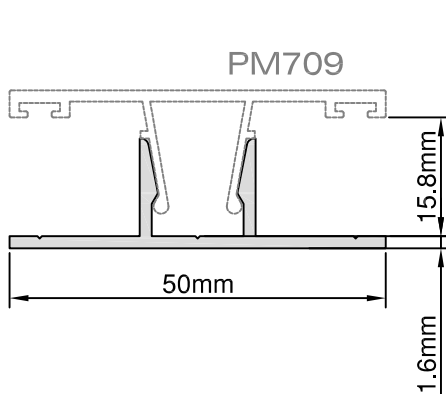

Sold
Separately
SCE52-22
Bulb Seal

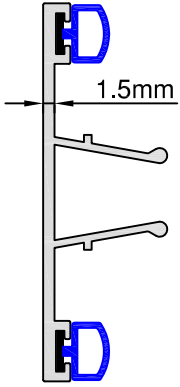

PM709
SNAP COVER
A/P: 191.85 mm
L/W: 0.342 kg/m

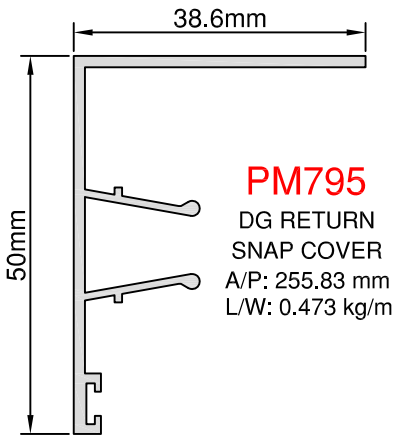
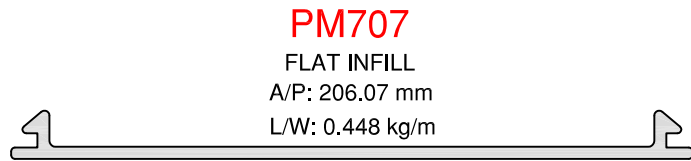
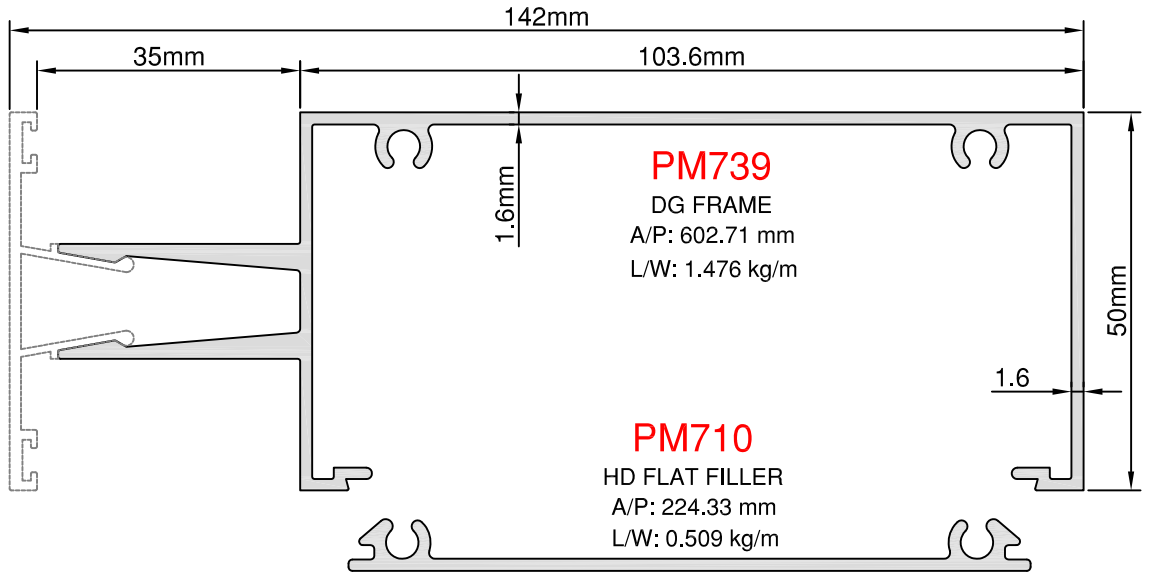

**DETAIL
SCALE 1:1**

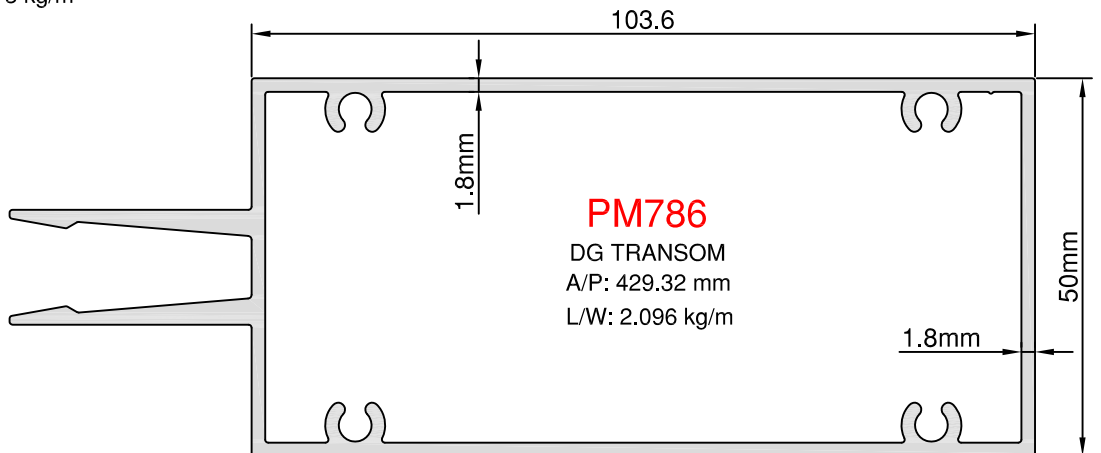

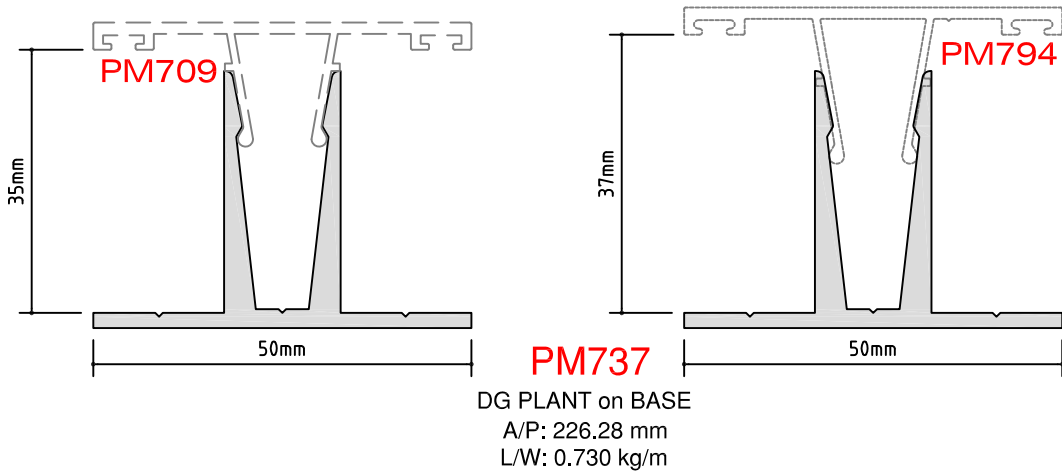
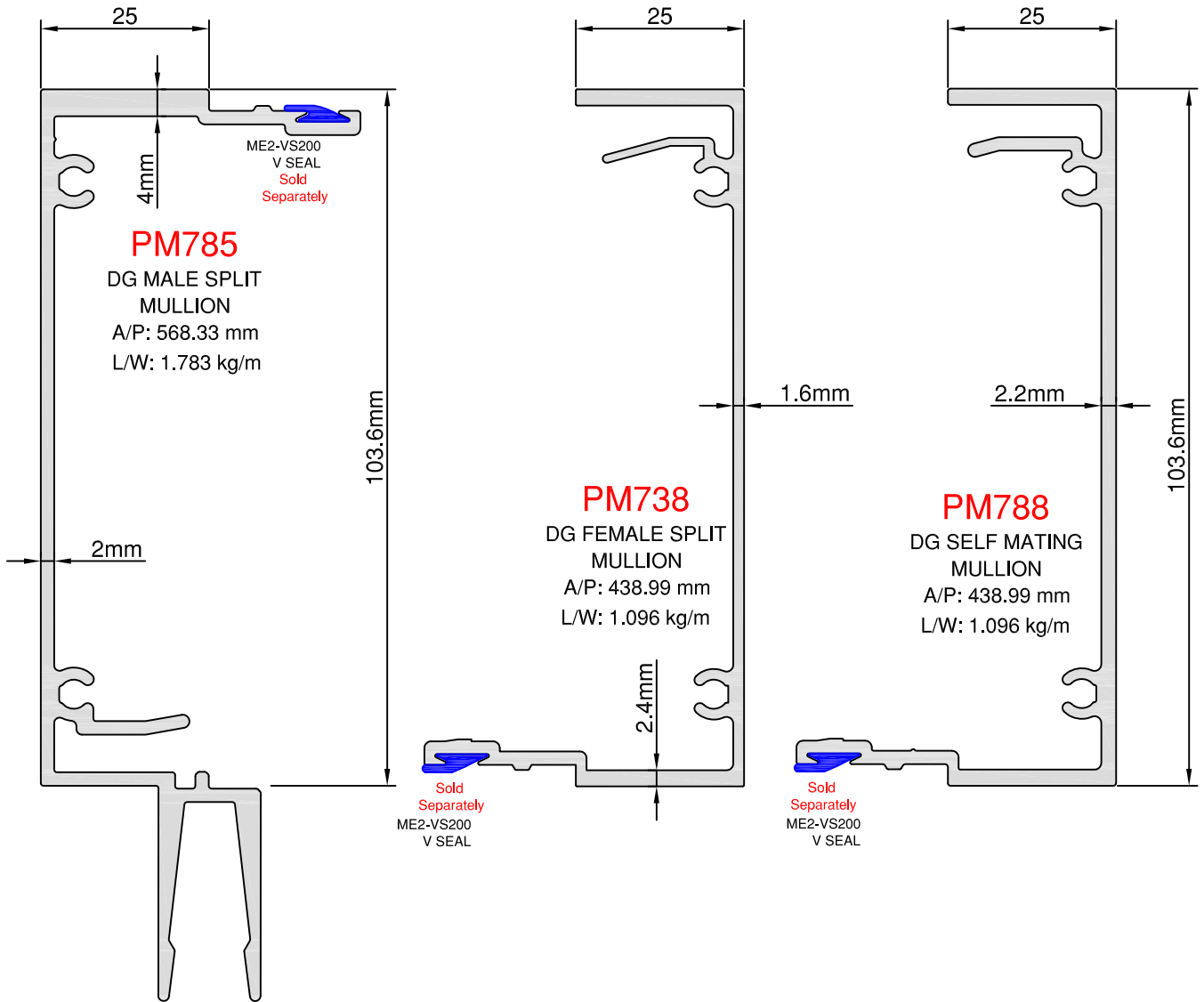

ME2 - COMMERCIAL DOORS

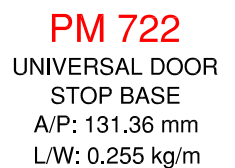
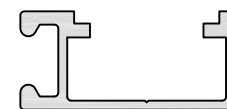
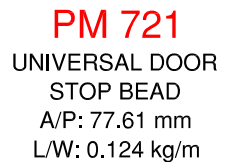
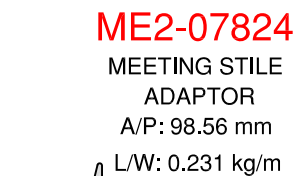
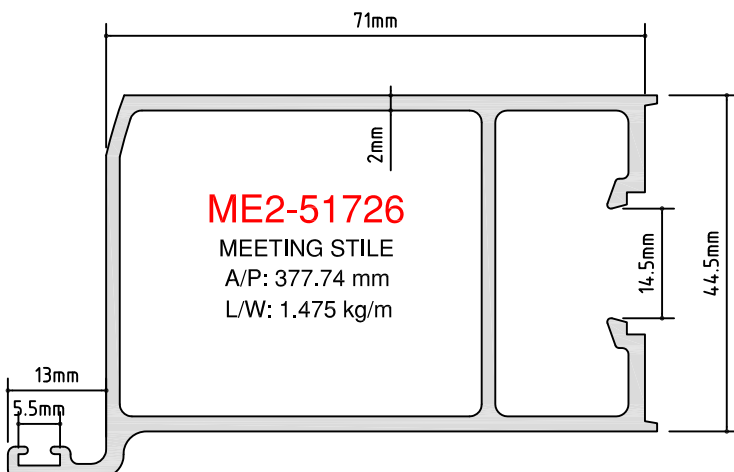
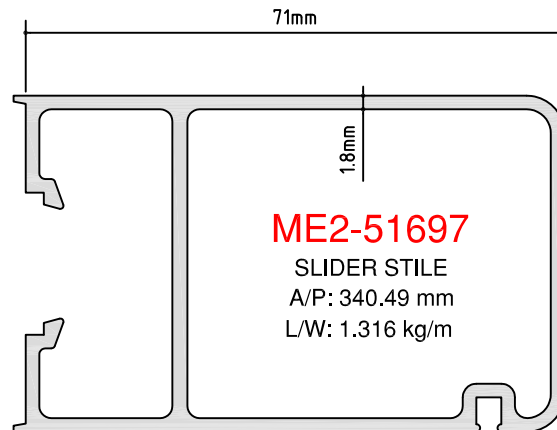
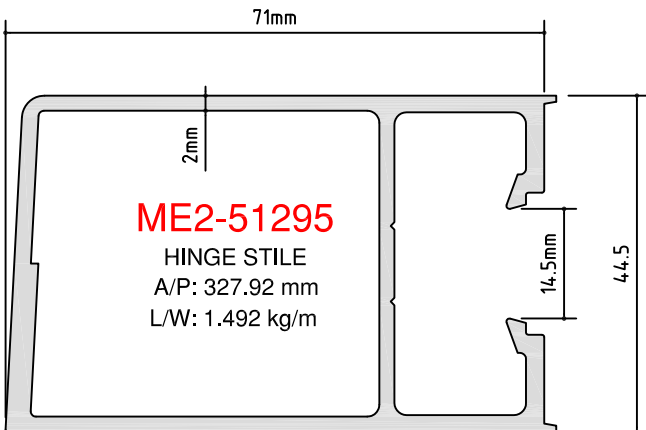
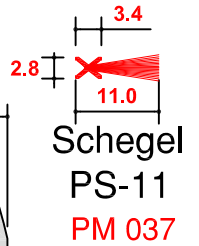
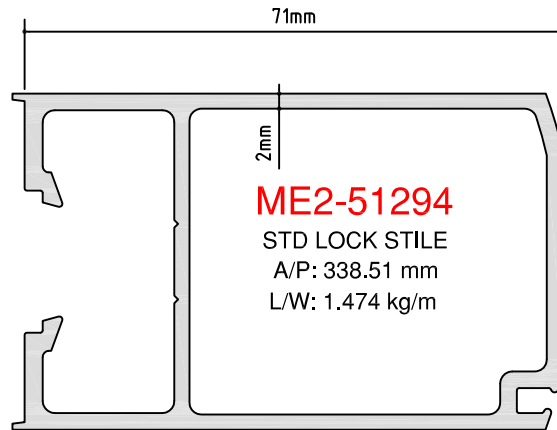
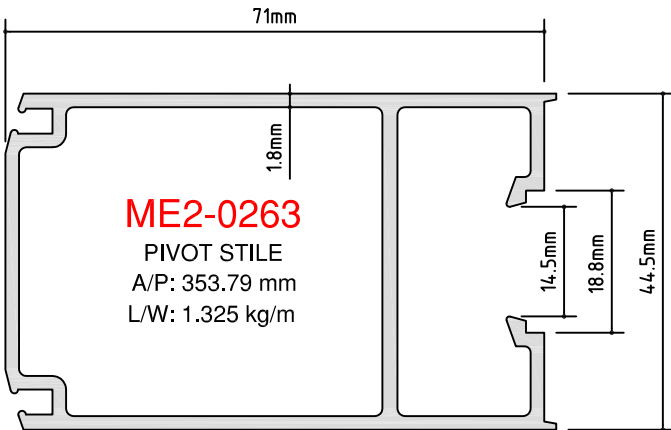
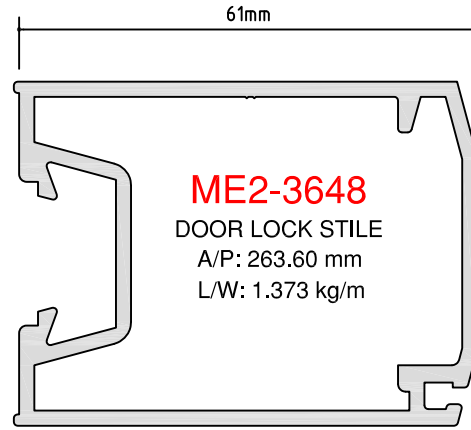
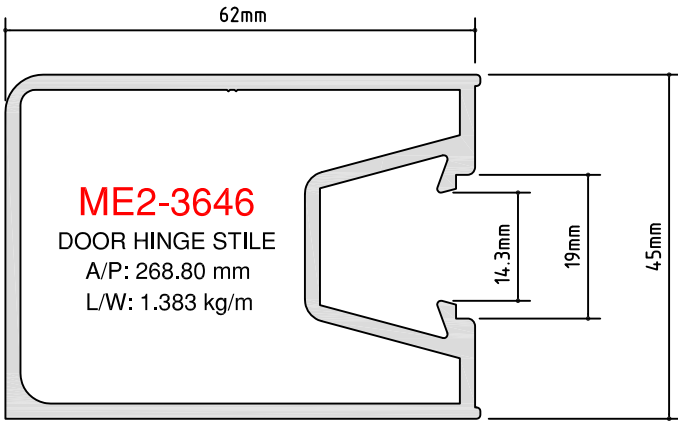

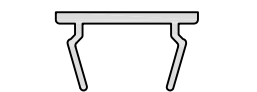
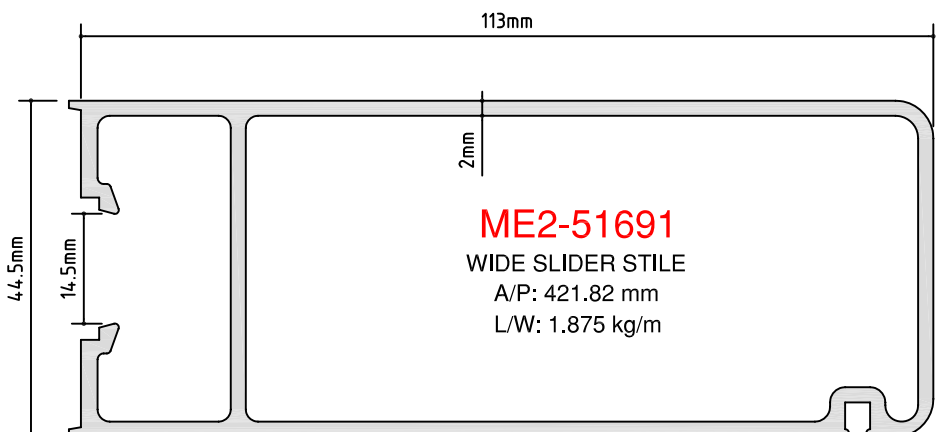
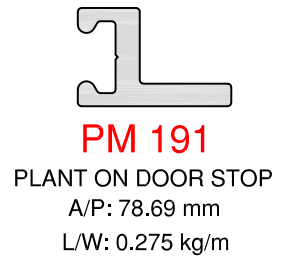
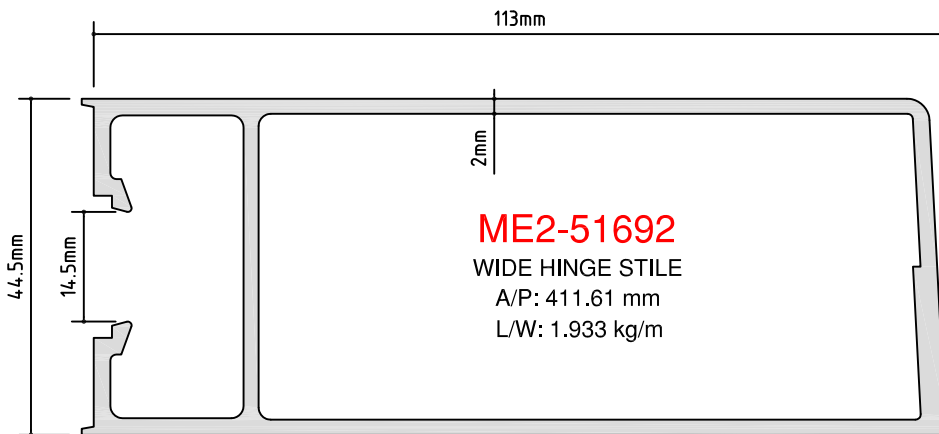
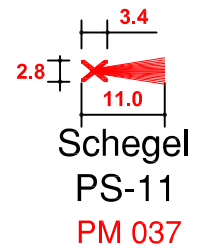
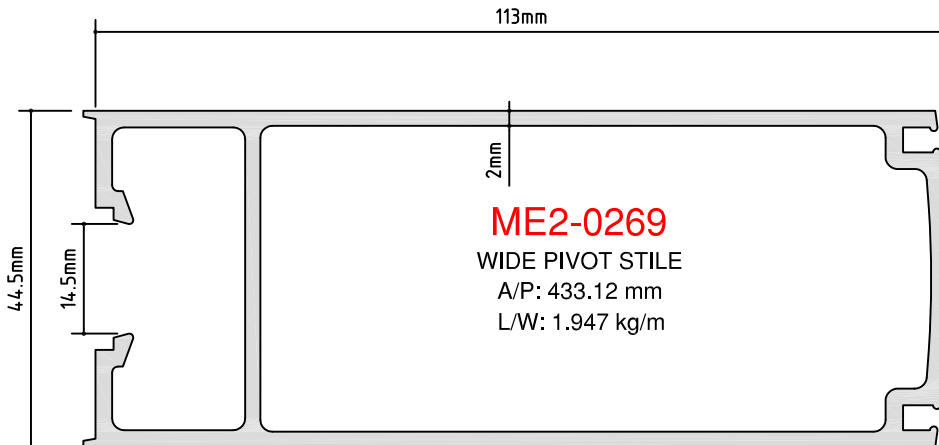
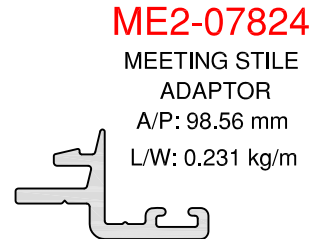
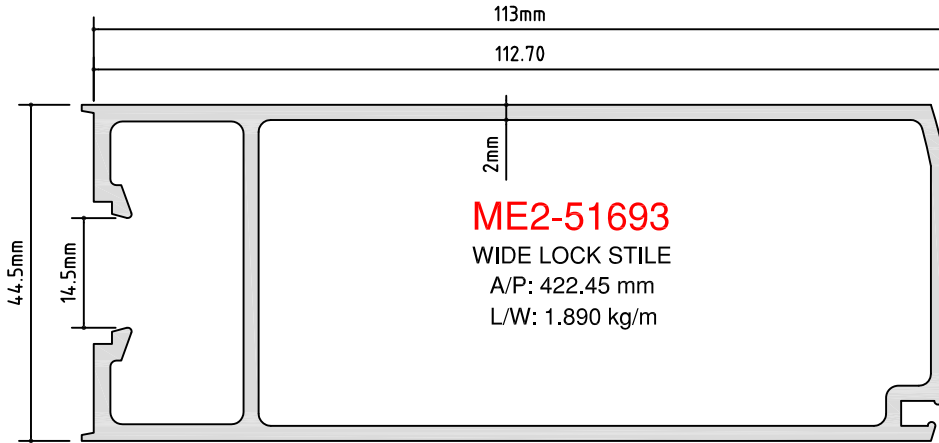

PM 721
UNIVERSAL DOOR
STOP BEAD
A/P: 77.61 mm
L/W: 0.124 kg/m

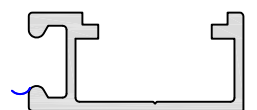

PM 722
UNIVERSAL DOOR
STOP BASE
A/P: 131.36 mm
L/W: 0.255 kg/m

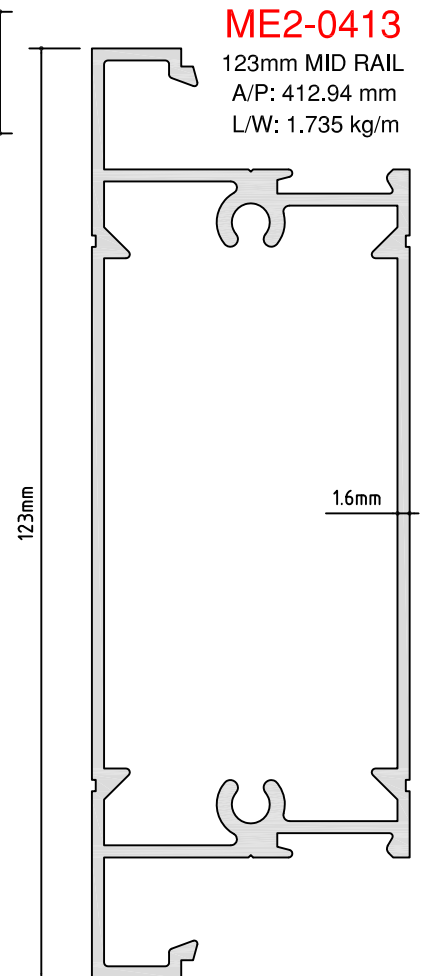
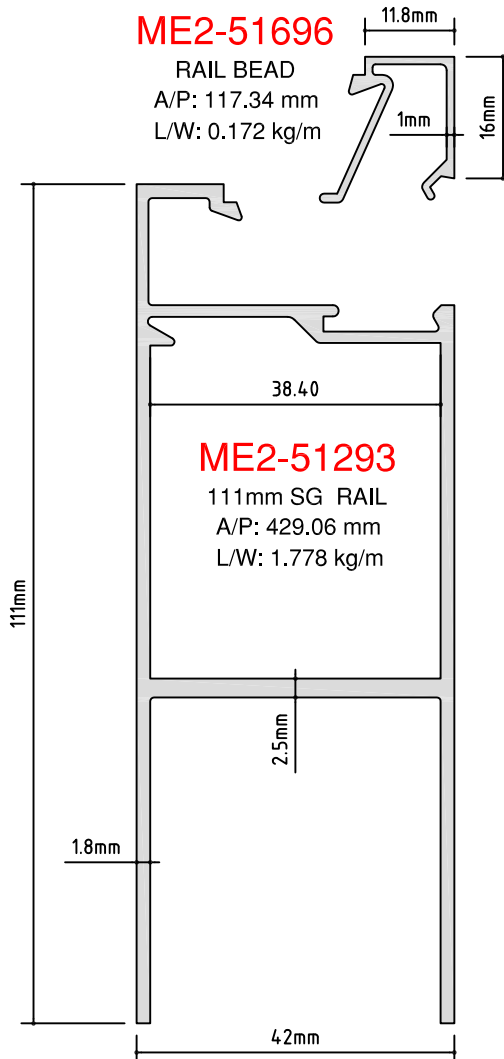
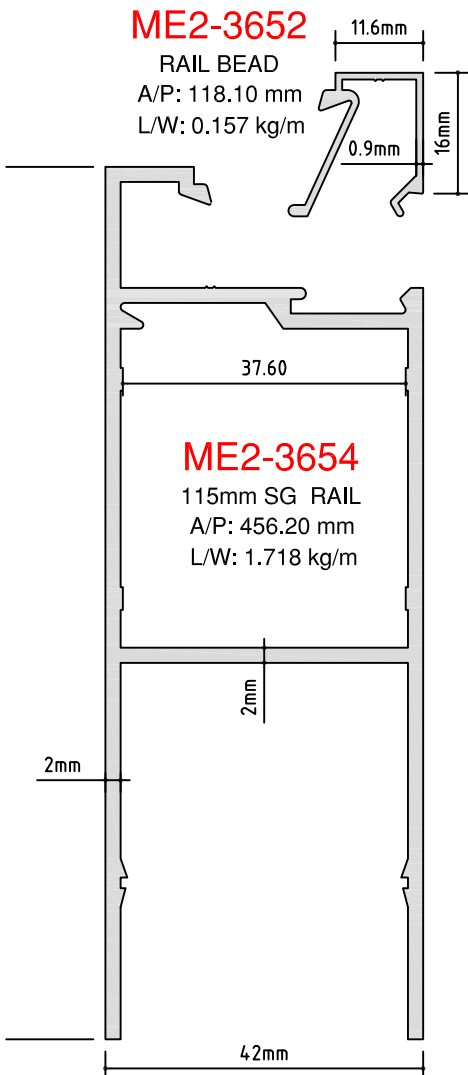
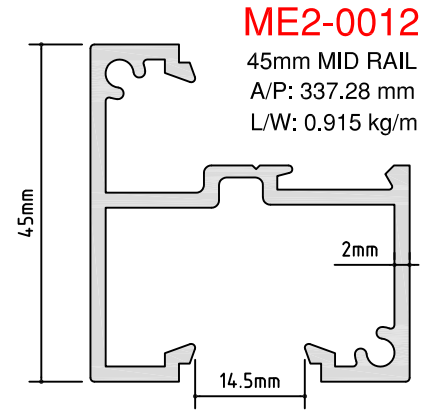
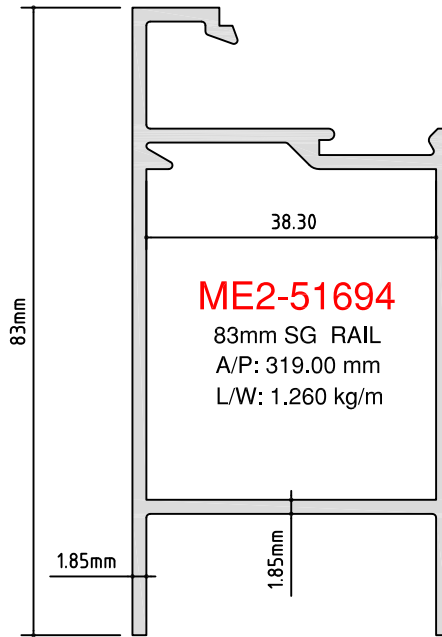
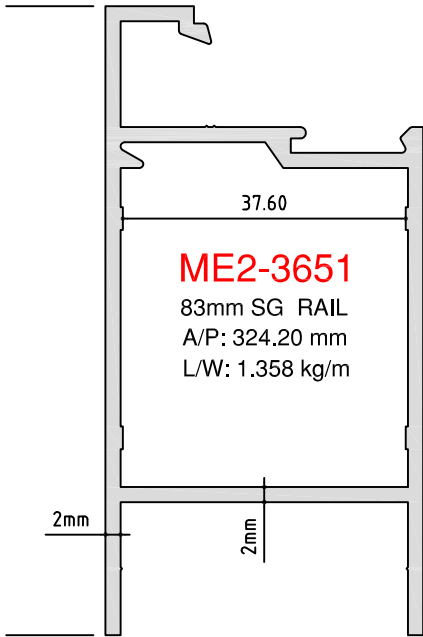

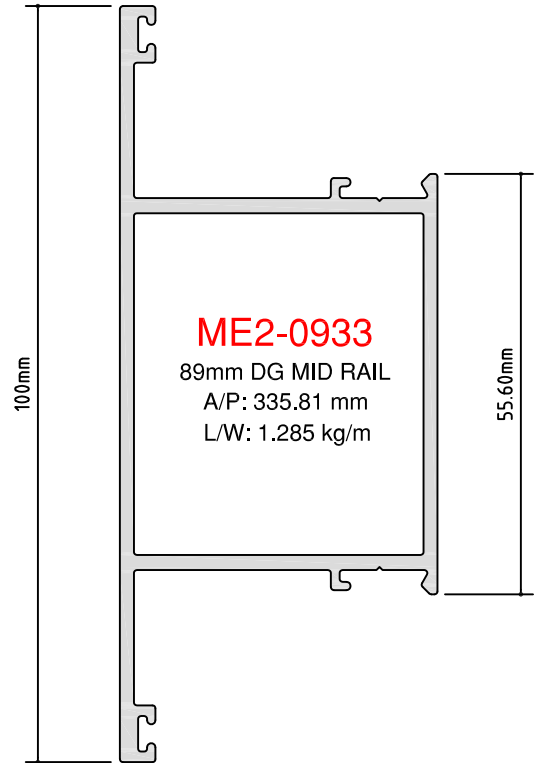
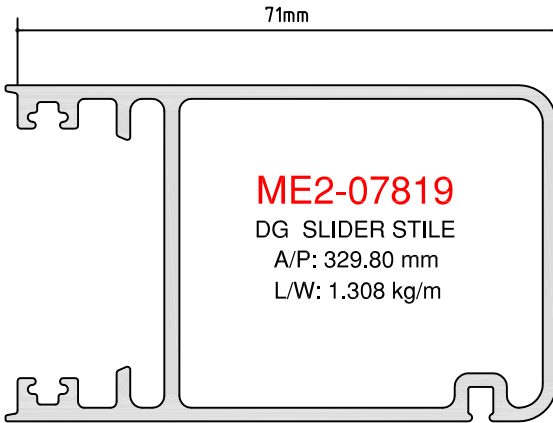
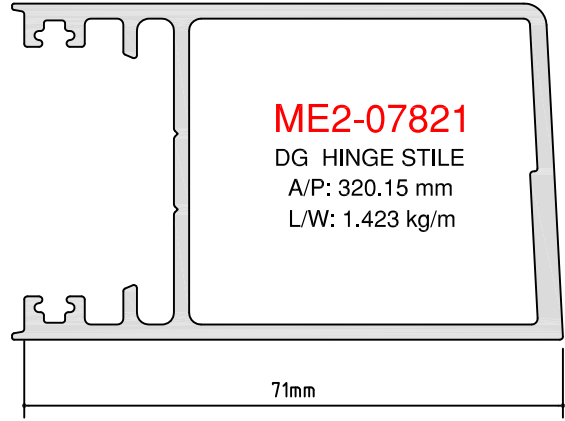
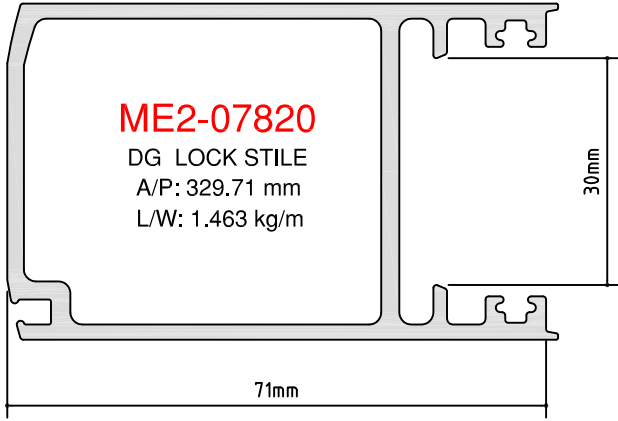

Schegel
PS-11
PM 037

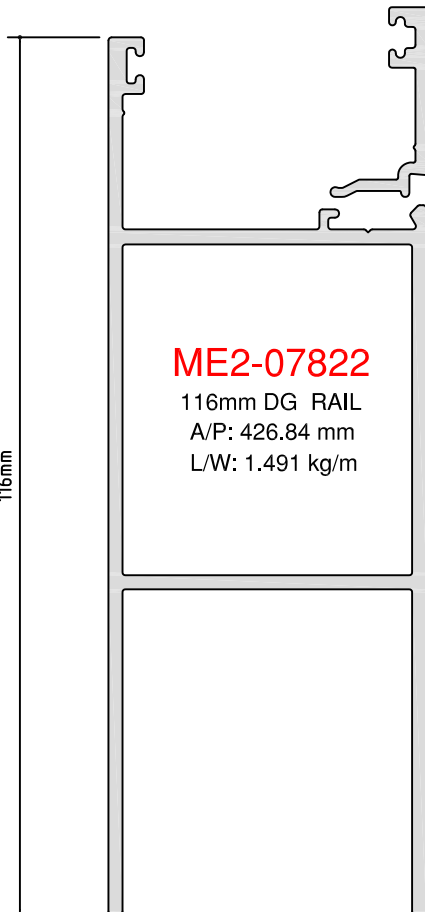
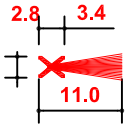

ME2-07823
DG BEAD
A/P: 89.33 mm
L/W: 0.183 kg/m

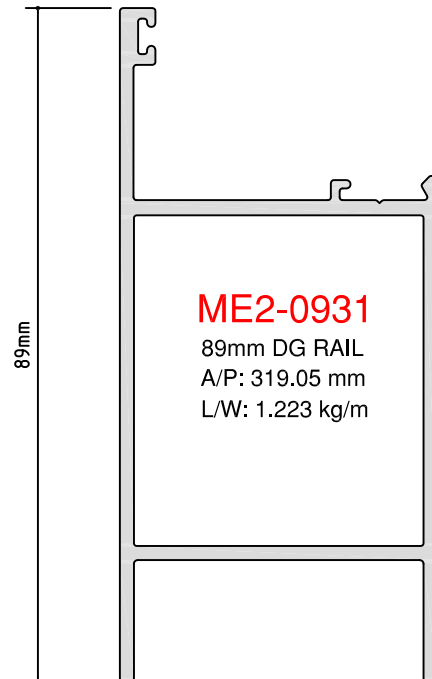

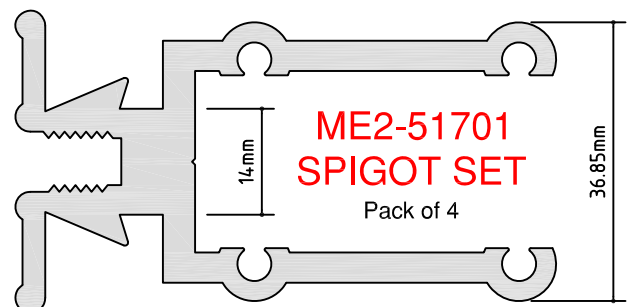
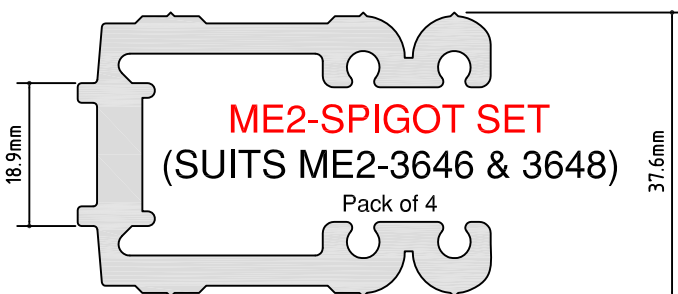
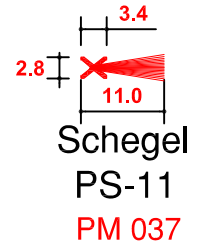
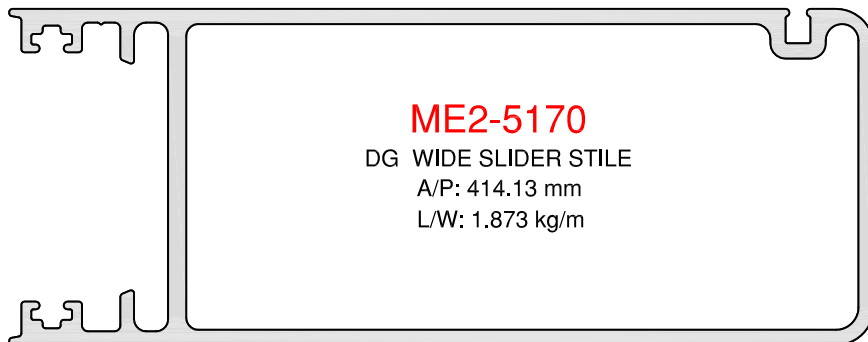
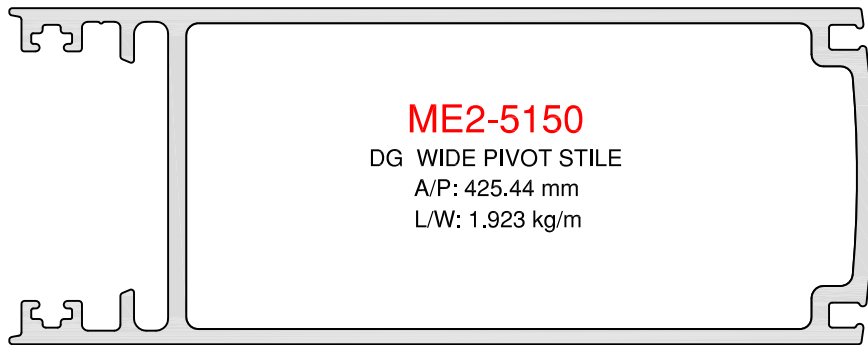
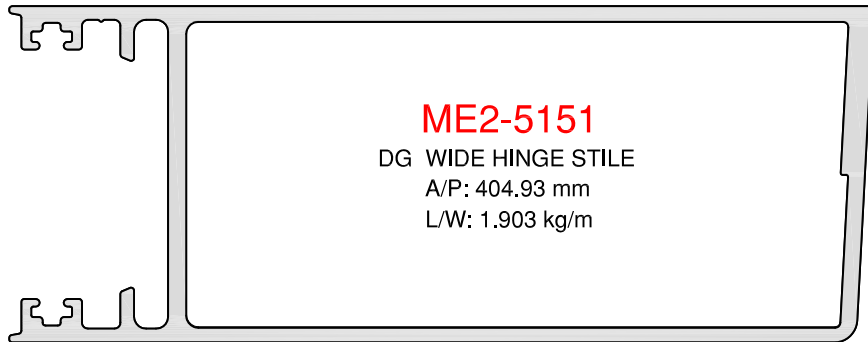
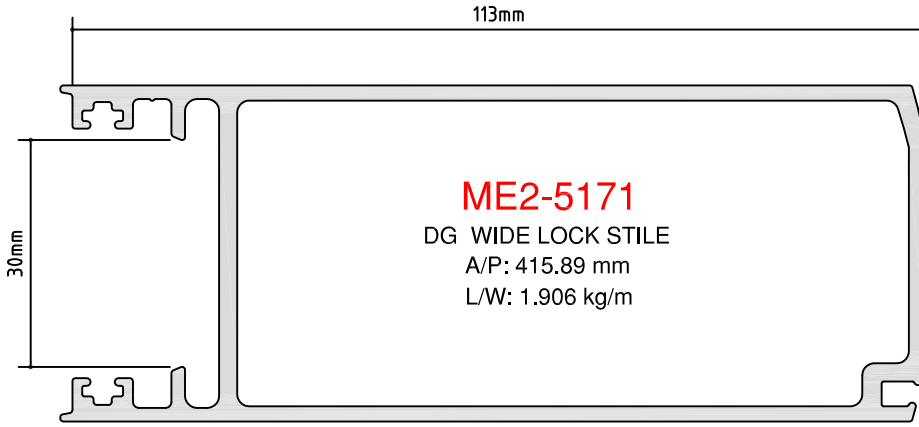

PM 222

OVERLAP SASH HINGE
A/P: 214.94 mm
L/W: 0.683 kg/m

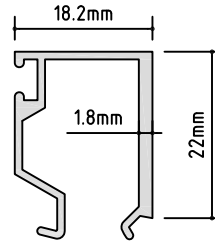
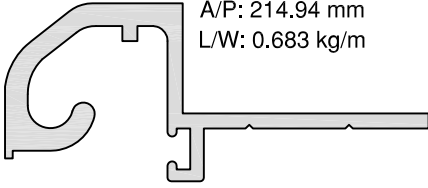

PM 129

SASH BEAD
A/P: 157.84 mm
L/W: 0.271 kg/m

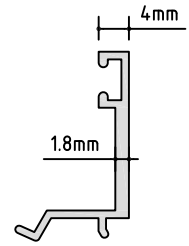

PM 128

SASH BEAD
A/P: 97.45 mm
L/W: 0.132 kg/m

SCALE 1:1

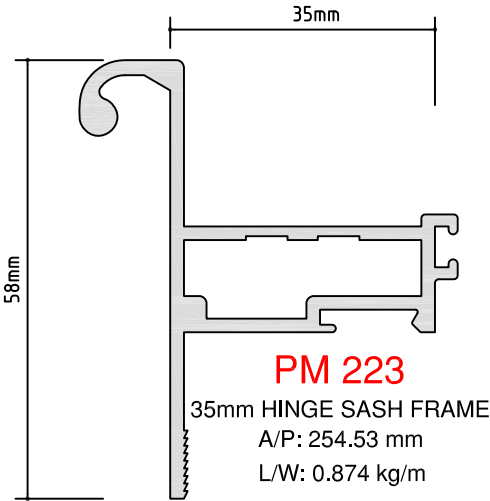

PM 223

35mm HINGE SASH FRAME
A/P: 254.53 mm
L/W: 0.874 kg/m

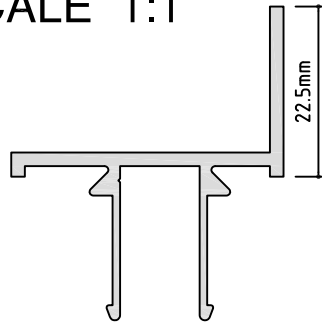

ME2-20233

35mm SASH STOP INFILL
(SUITS 101.6 x 44.4 SG FRAME)
A/P: 208.77 mm
L/W: 0.438 kg/m

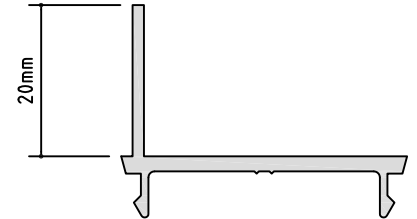

ME2-52105

DG 35mm AWNING SASH ADAPTOR
(SUITS 101.6 x 50mm DG FRAME)
A/P: 142.75 mm
L/W: 0.326 kg/m

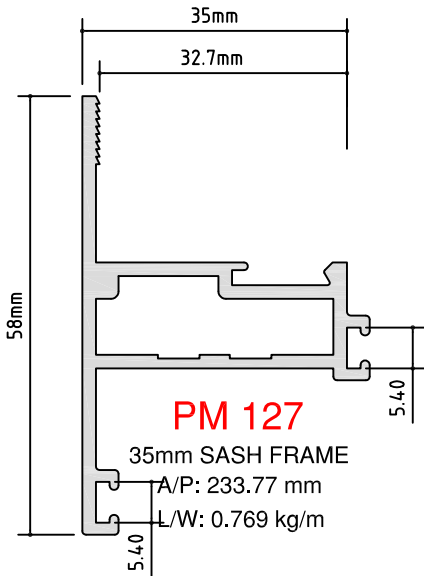

PM 127

35mm SASH FRAME
A/P: 233.77 mm
L/W: 0.769 kg/m

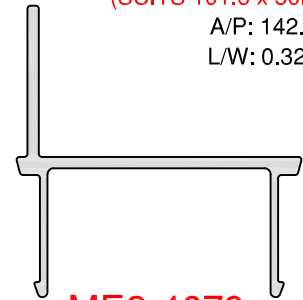

ME2-4679

35mm SASH ADAPTOR
SUITS 101.6 x 44.4 DG FRAME
A/P: 184.13 mm
L/W: 0.343 kg/m

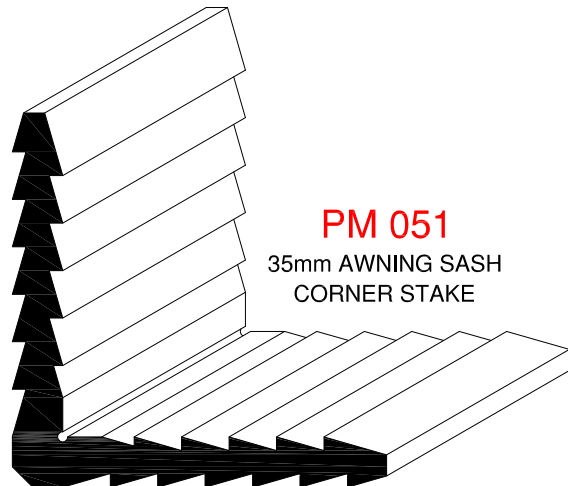

PM 051

35mm AWNING SASH CORNER STAKE

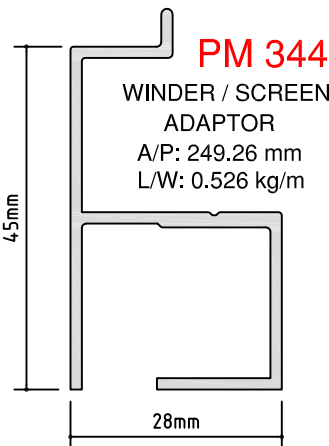

PM 344

WINDER / SCREEN ADAPTOR
A/P: 249.26 mm
L/W: 0.526 kg/m

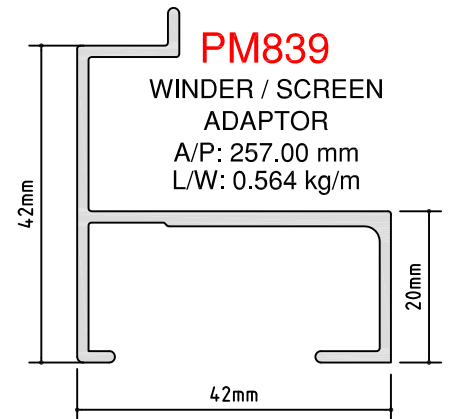

PM839

WINDER / SCREEN ADAPTOR
A/P: 257.00 mm
L/W: 0.564 kg/m



SCALE 1:1

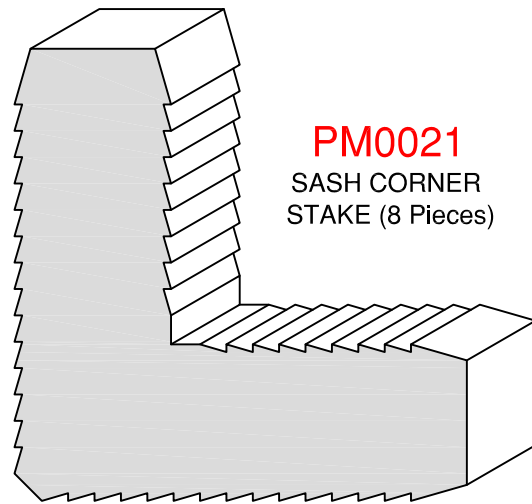
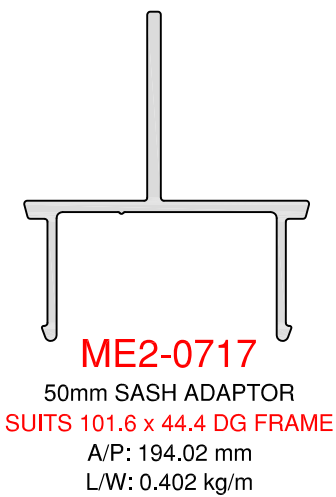
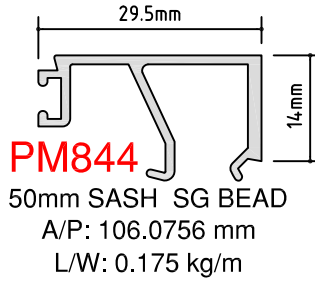
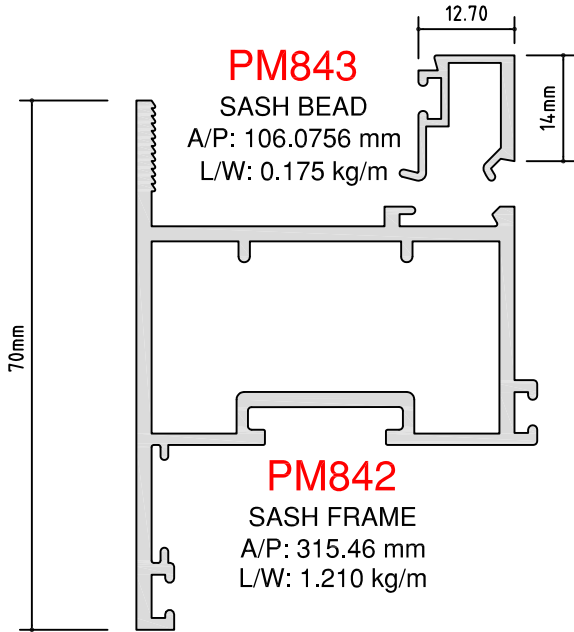



**3001 - 3002 SERIES
67mm SLIDING WINDOWS**

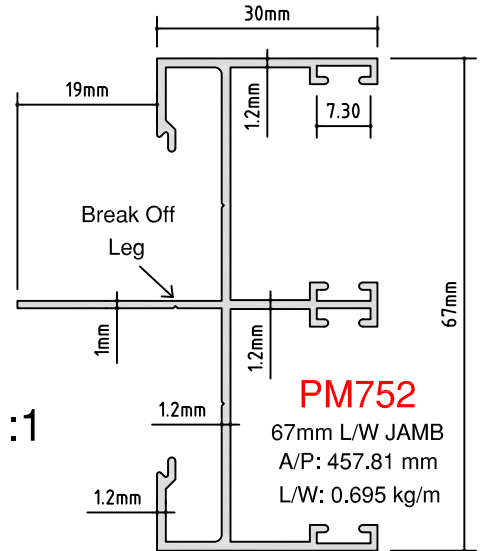
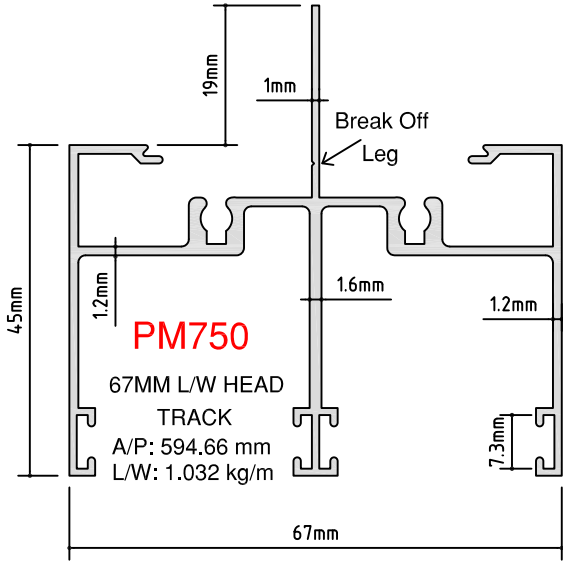

SCALE 1:1

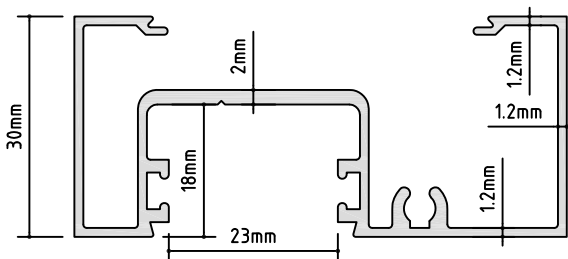
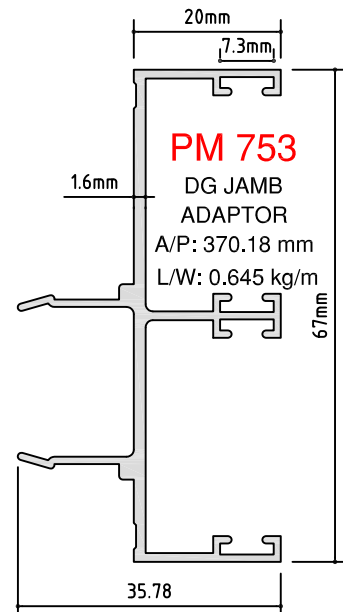
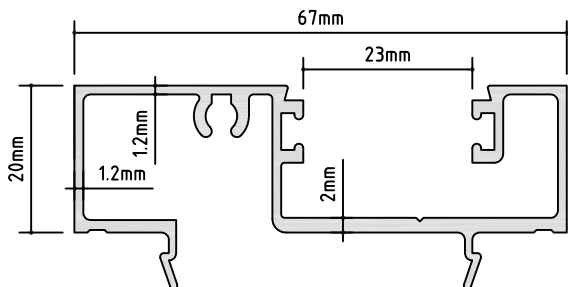
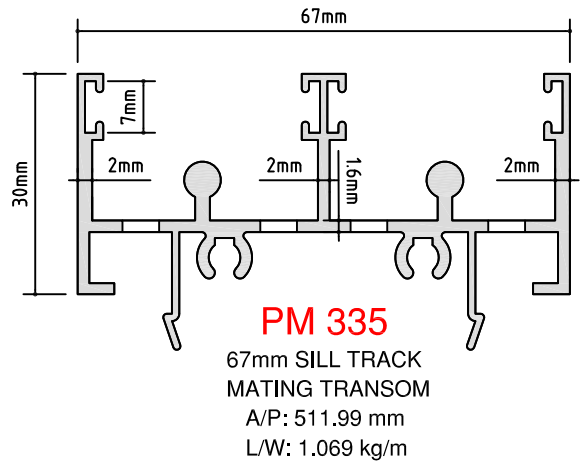
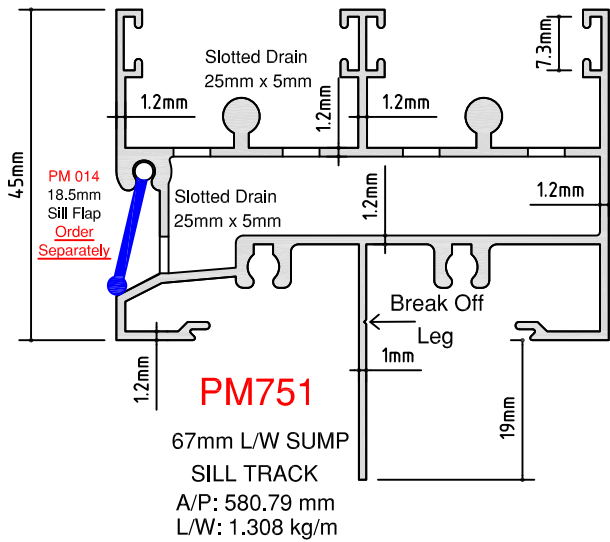



**3001 - 3002 SERIES
67mm SLIDING WINDOWS**

SCALE 1:1

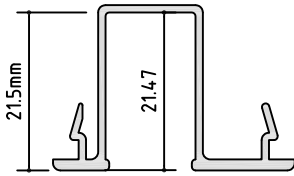

PM 755
SCREEN ADAPTOR
A/P: 184.12 mm
L/W: 0.276 kg/m

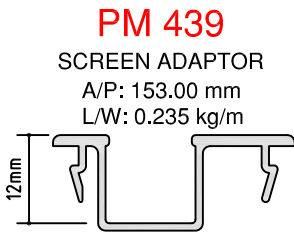

PM 439
SCREEN ADAPTOR
A/P: 153.00 mm
L/W: 0.235 kg/m

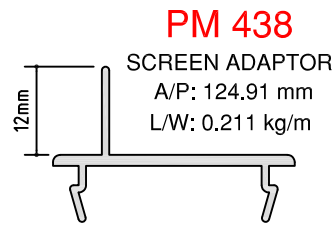

PM 438
SCREEN ADAPTOR
A/P: 124.91 mm
L/W: 0.211 kg/m



FLE0952
FLY SCREEN FRAME
A/P: 82.90 mm
L/W: 0.134 kg/m

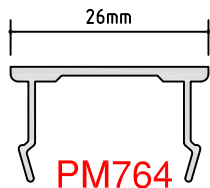

PM764
67mm
DG POCKET FILLER
A/P: 113.88 mm
L/W: 0.185 kg/m

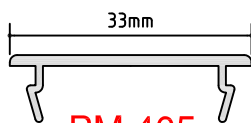

PM 405
PLAIN TRACK INFILL
A/P: 101.34 mm
L/W: 0.179 kg/m

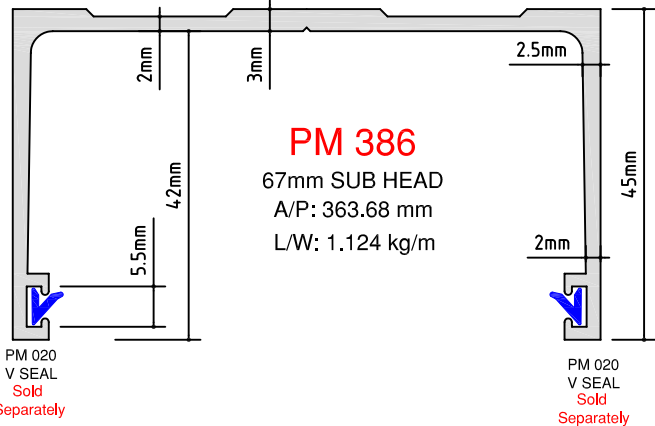

PM 386
67mm SUB HEAD
A/P: 363.68 mm
L/W: 1.124 kg/m

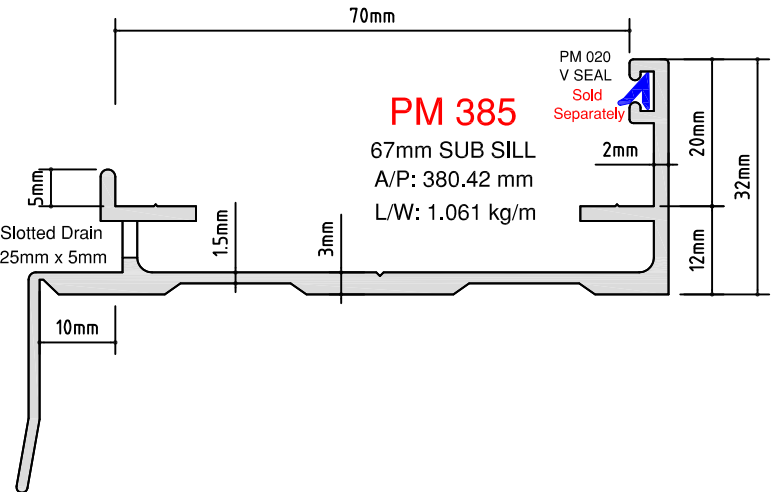

PM 385
67mm SUB SILL
A/P: 380.42 mm
L/W: 1.061 kg/m

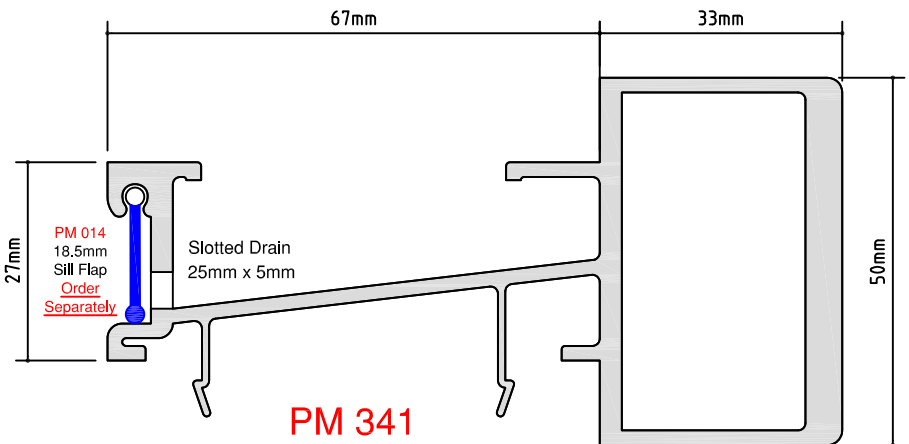

PM 341
50mm TRANSOM STIFFENER
A/P: 476.04 mm
L/W: 2.237 kg/m



**3003 - 3006 SERIES
100mm SLIDING WINDOWS & DOORS**

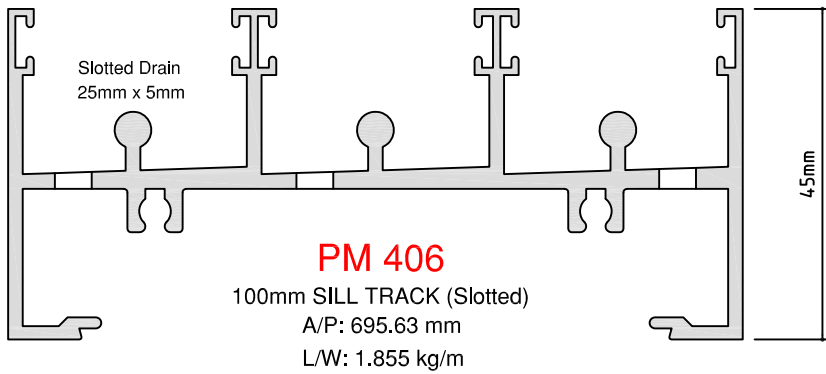
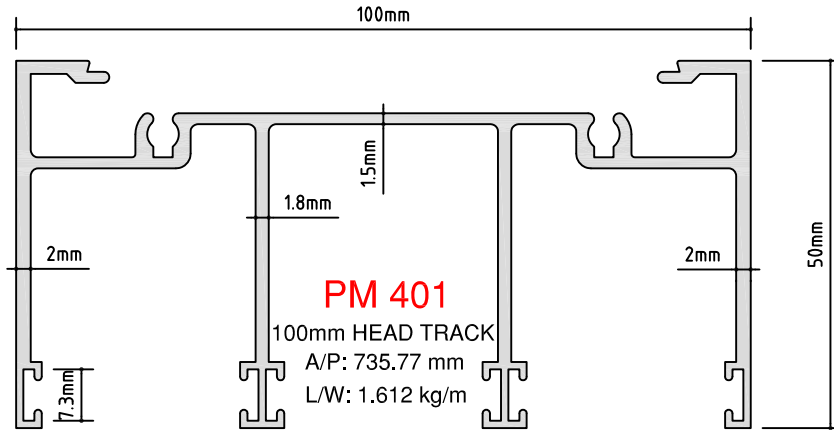

SCALE 1:1

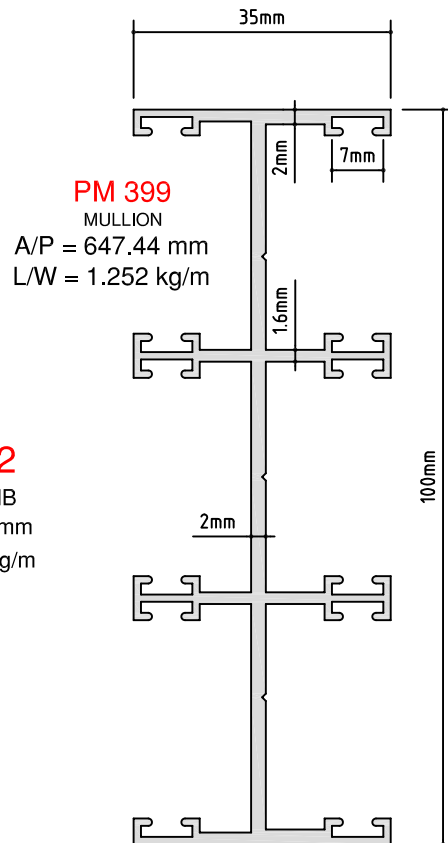
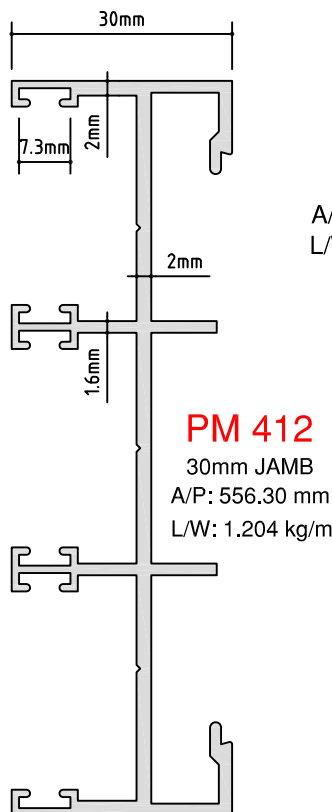
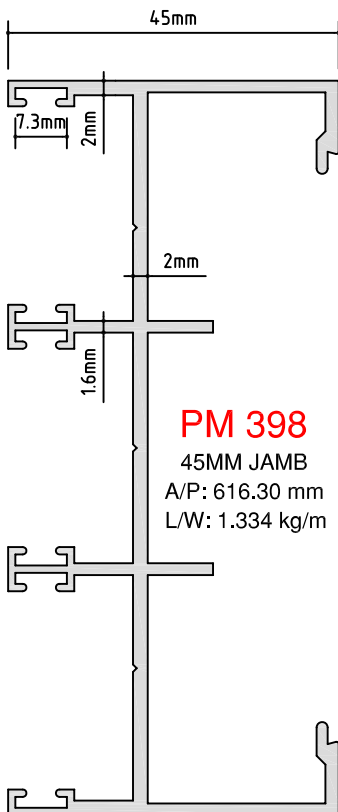
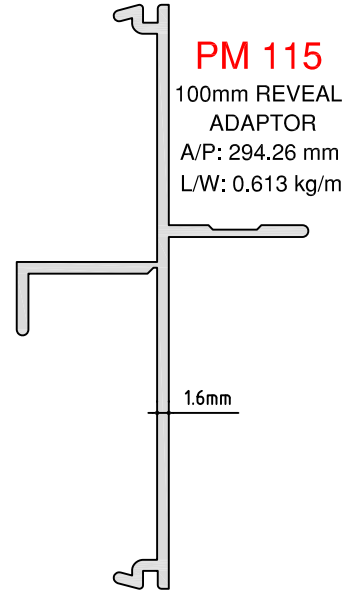



3003 - 3006 SERIES
100mm SLIDING WINDOWS & DOORS

SCALE 1:1

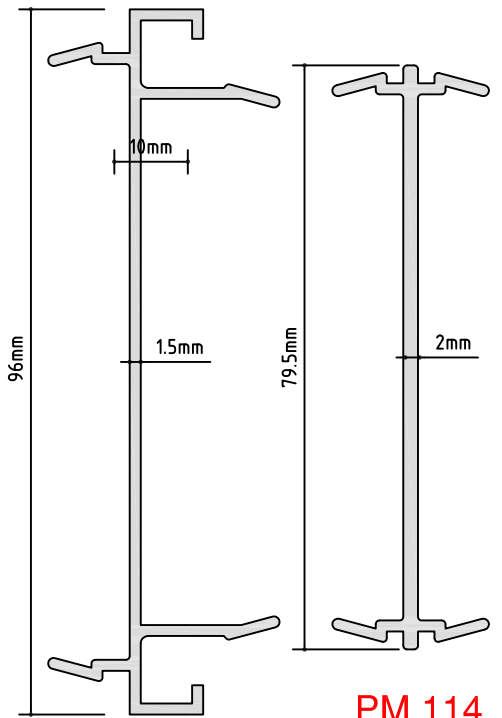
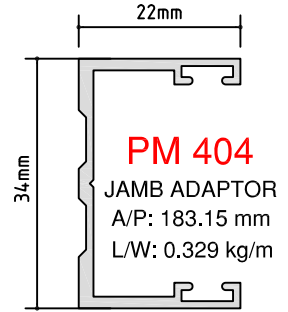
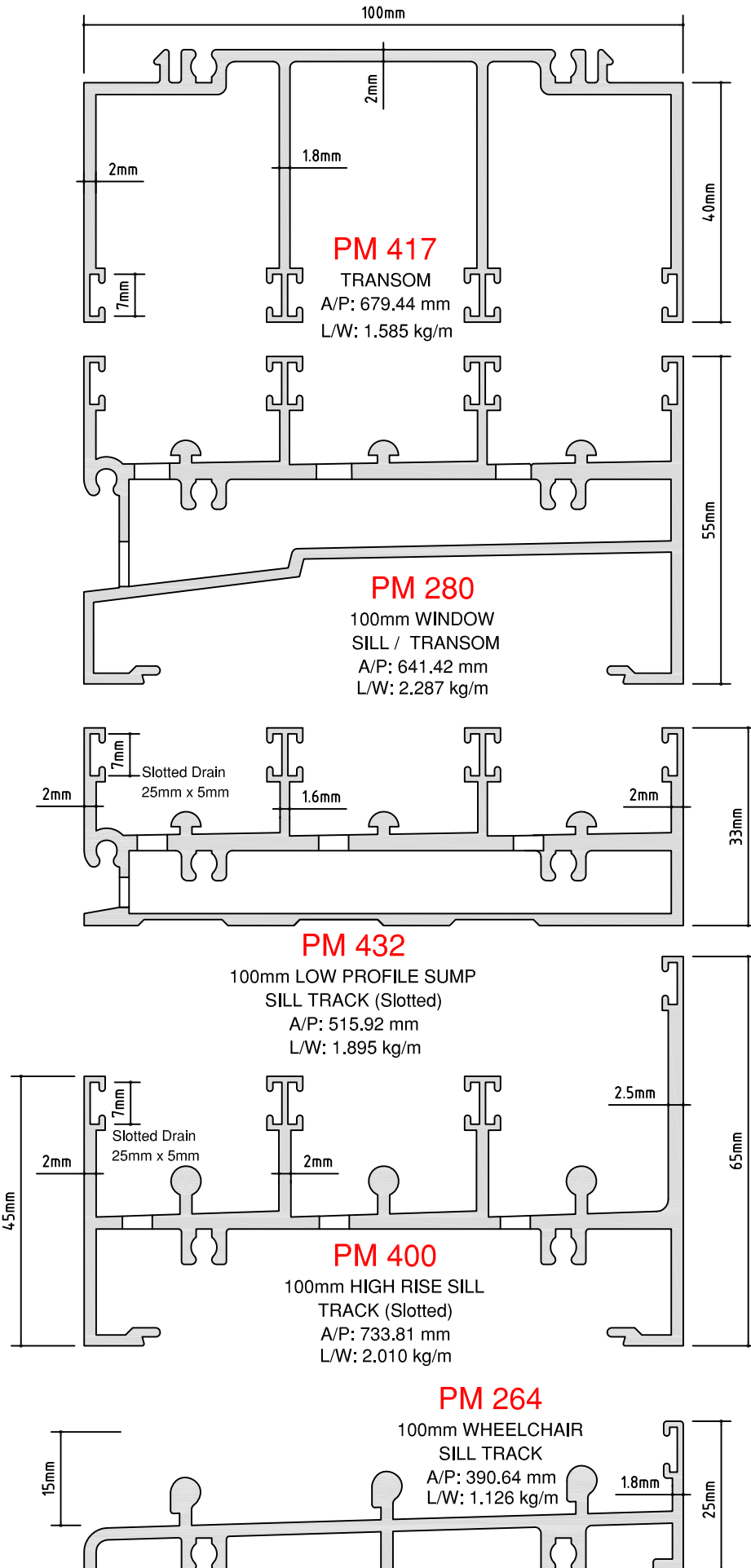



SCALE 1:1

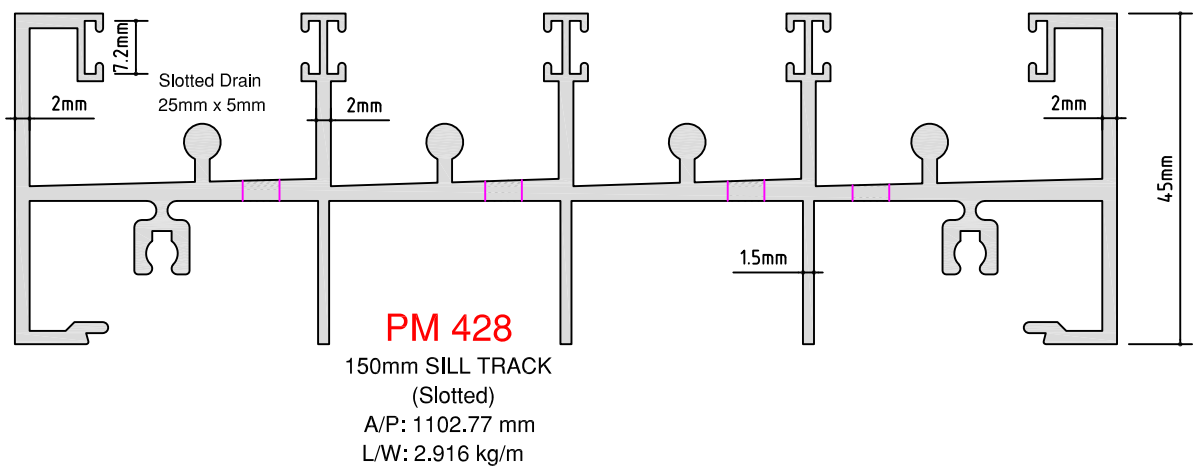
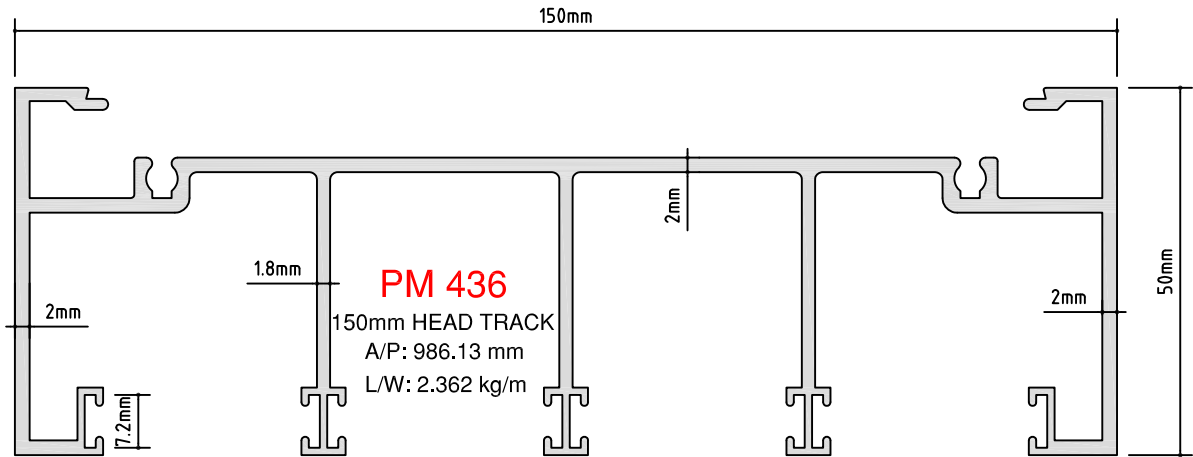



3005 - 3006 SERIES
150mm SLIDING DOORS

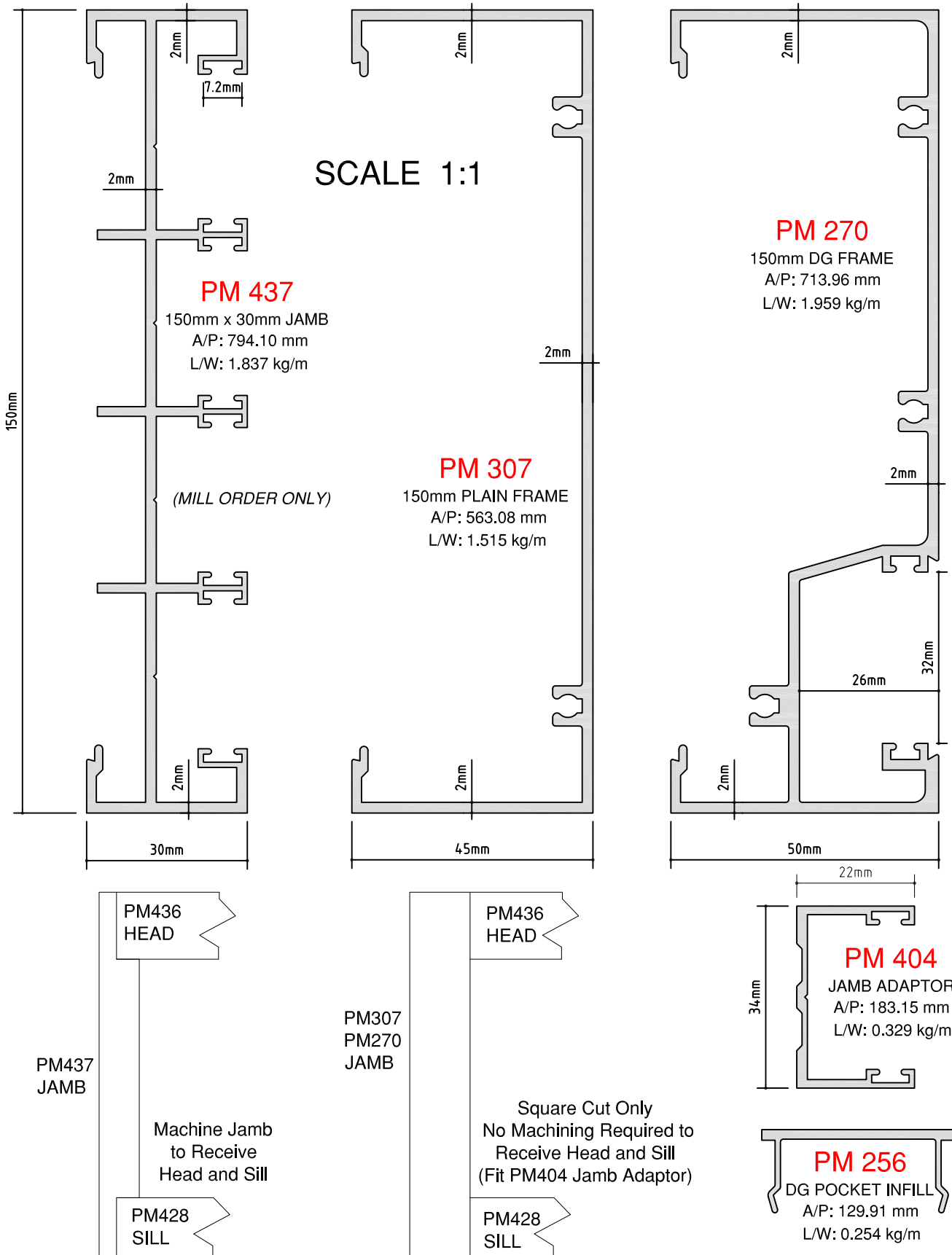



3005 - 3006 SERIES
164mm SLIDING DOORS

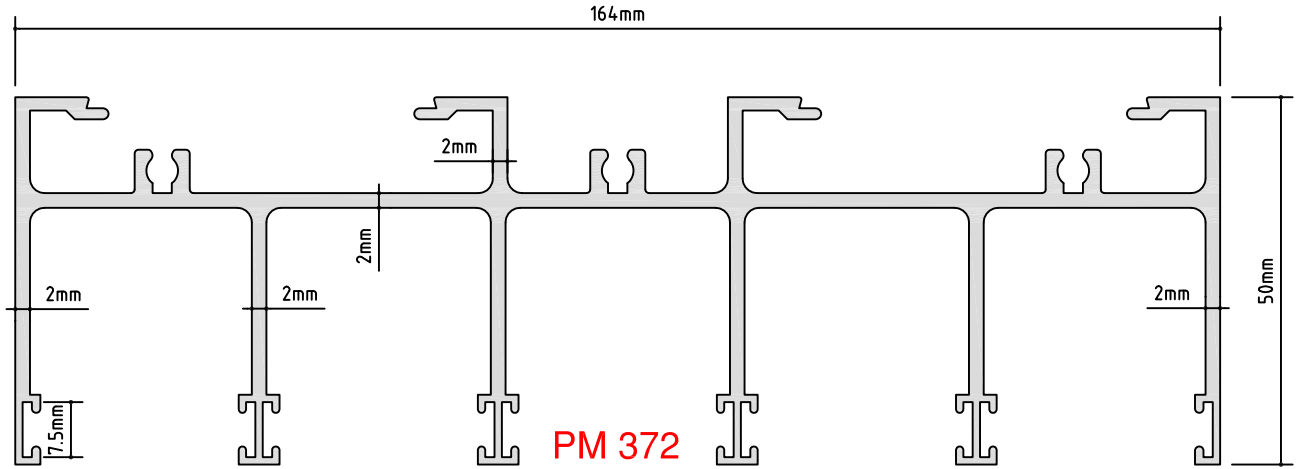

PM 372
164mm HEAD TRACK
A/P: 1131.63 mm
L/W: 2.818 kg/m

SCALE 1:1

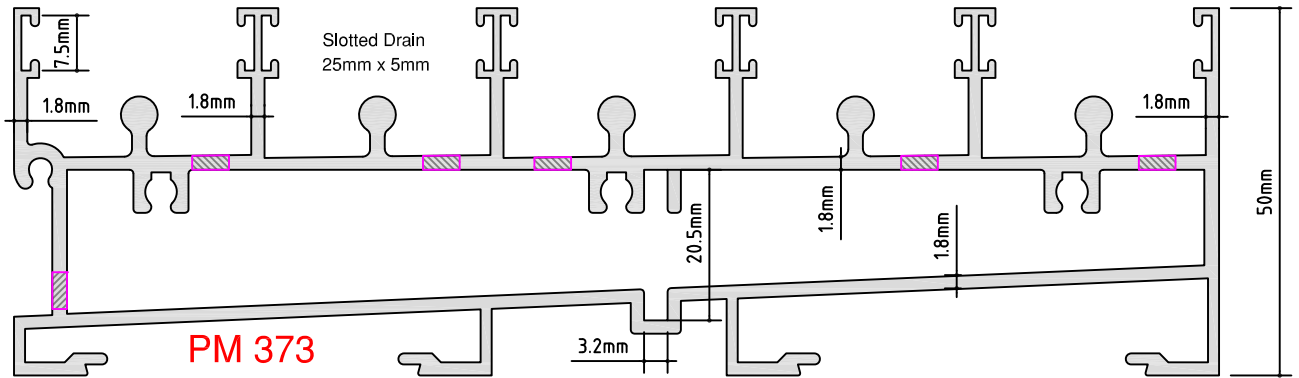

PM 373
164mm SILL TRACK
A/P: 1025.77 mm
L/W: 3.506 kg/m

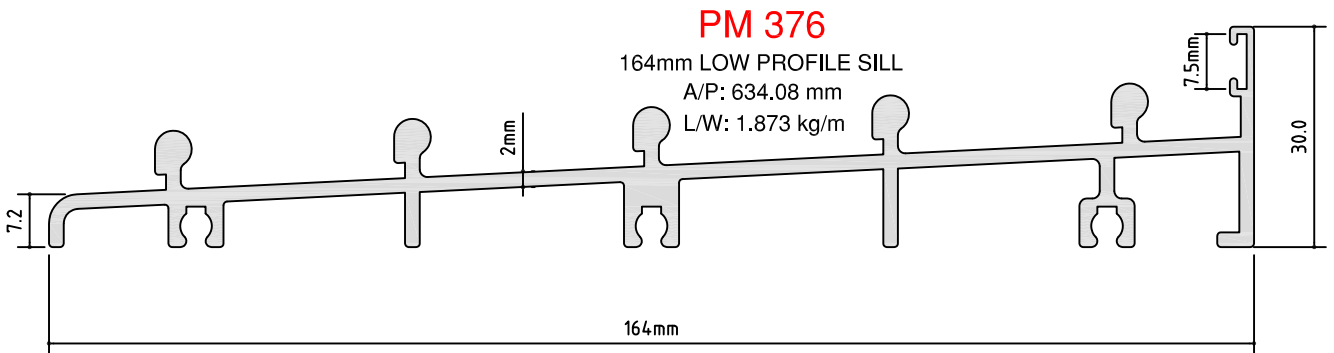

PM 376
164mm LOW PROFILE SILL
A/P: 634.08 mm
L/W: 1.873 kg/m

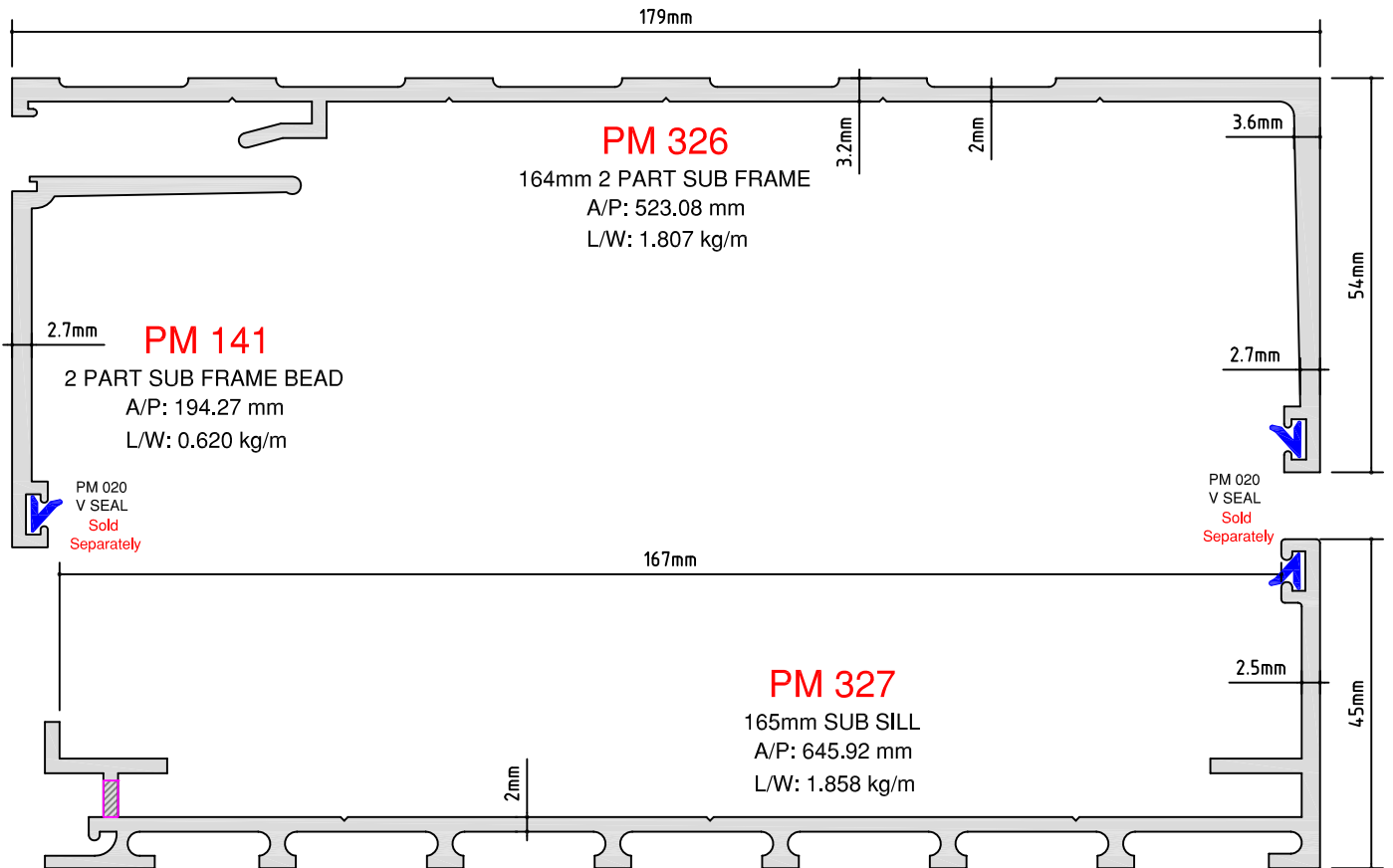
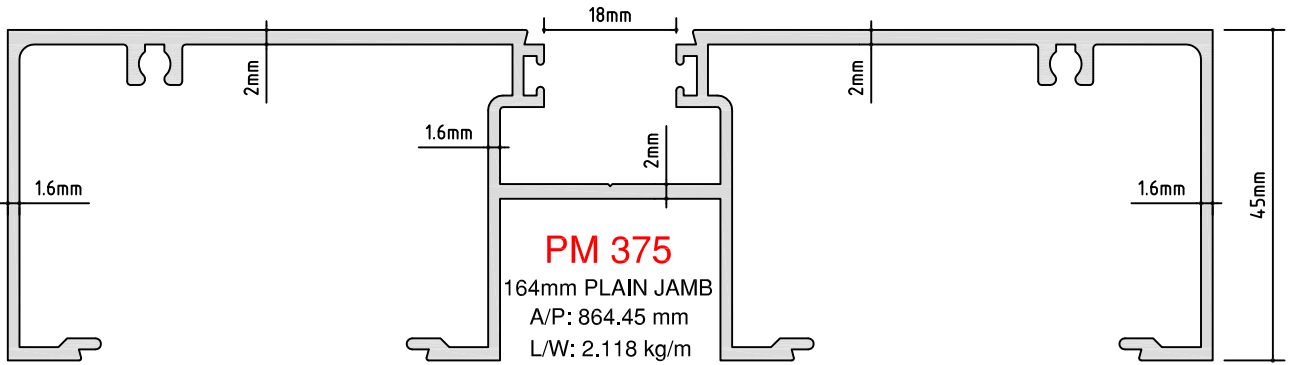
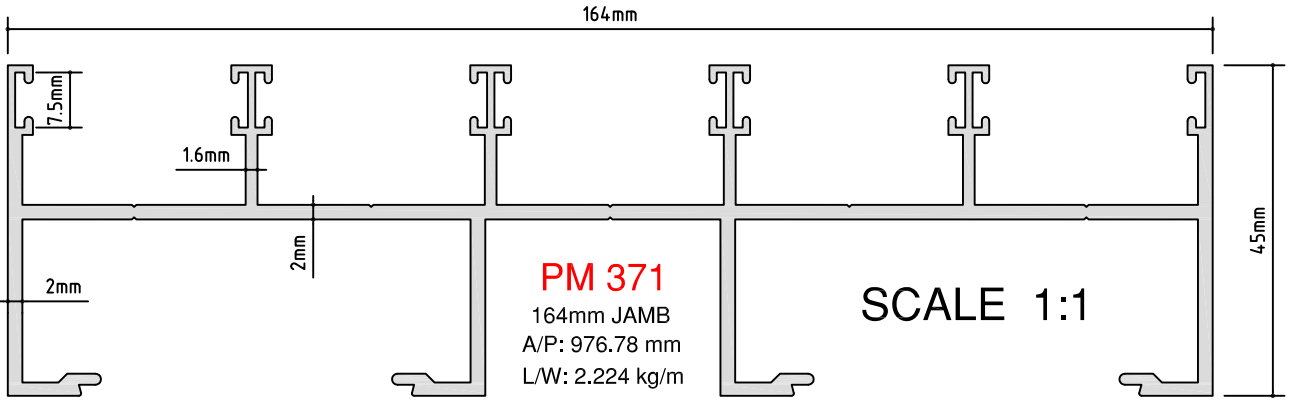



**3000 SERIES
DG PANEL SECTIONS**

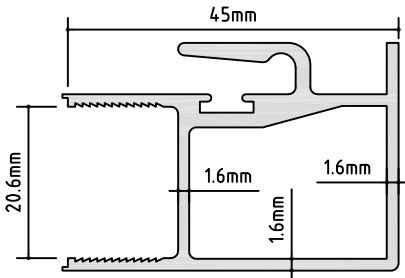

PM767
DG STANDARD INTERLOCK
A/P: 252.38 mm
L/W: 0.787 kg/m

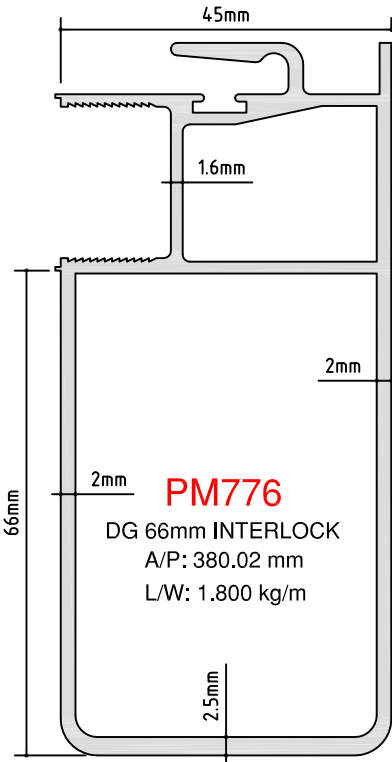

PM776
DG 66mm INTERLOCK
A/P: 380.02 mm
L/W: 1.800 kg/m

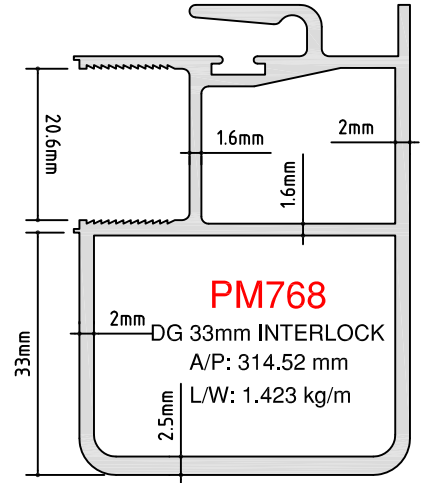

PM768
DG 33mm INTERLOCK
A/P: 314.52 mm
L/W: 1.423 kg/m

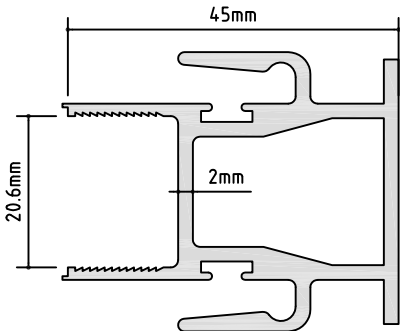

PM789
DOUBLE INTERLOCK
A/P: 320.15 mm
L/W: 1.006 kg/m

SCALE 1:1

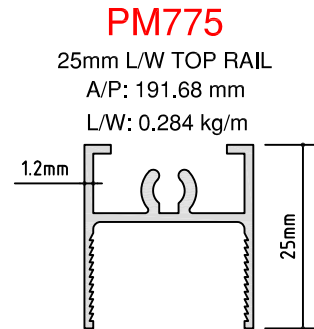

PM775
25mm L/W TOP RAIL
A/P: 191.68 mm
L/W: 0.284 kg/m

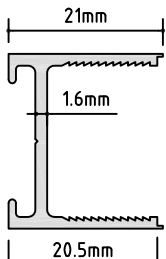

PM770
21mm L/W STILE
A/P: 150.08 mm
L/W: 0.265 kg/m

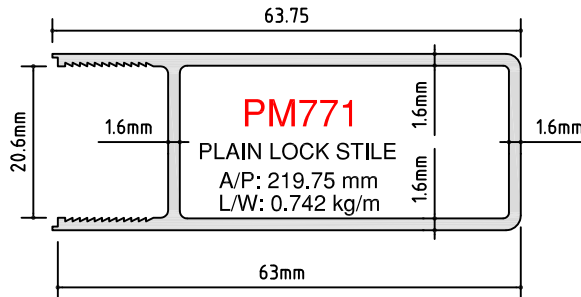

PM771
PLAIN LOCK STILE
A/P: 219.75 mm
L/W: 0.742 kg/m

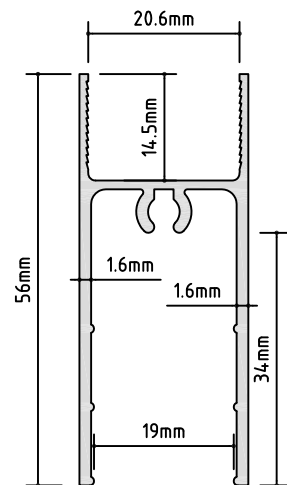

PM774
DG 56mm L/W RAIL
A/P: 306.00 mm
L/W: 0.612 kg/m



**3000 SERIES
DG PANEL SECTIONS**

PM772

FEMALE MEETING STILE
A/P: 253.08 mm
L/W: 0.739 kg/m

SCALE 1:1

PM769

MALE MEETING STILE
A/P: 237.54 mm
L/W: 0.768 kg/m

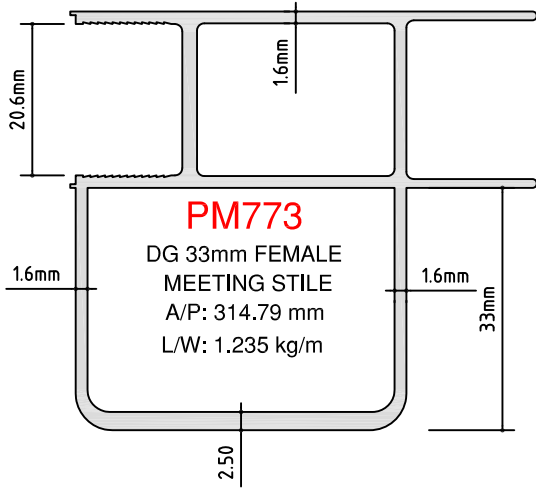
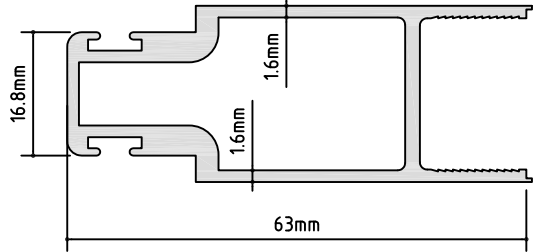
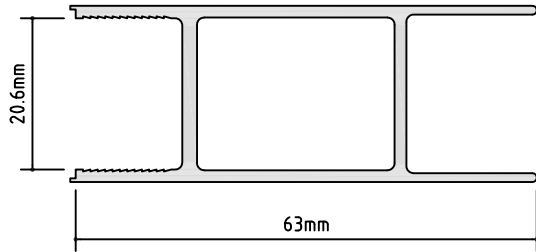

PM773

DG 33mm FEMALE
MEETING STILE
A/P: 314.79 mm
L/W: 1.235 kg/m

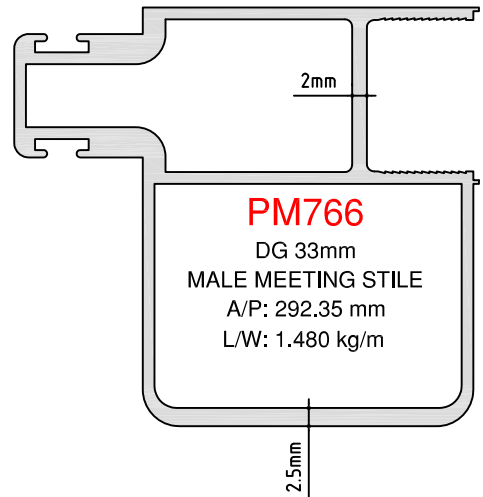

PM766

DG 33mm
MALE MEETING STILE
A/P: 292.35 mm
L/W: 1.480 kg/m

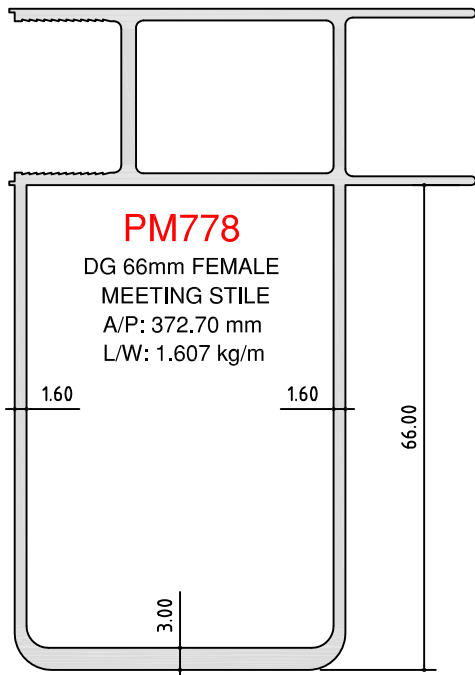

PM778

DG 66mm FEMALE
MEETING STILE
A/P: 372.70 mm
L/W: 1.607 kg/m

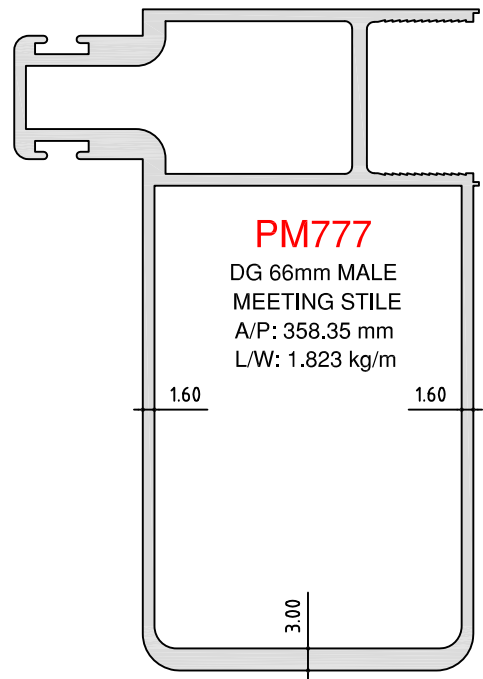

PM777

DG 66mm MALE
MEETING STILE
A/P: 358.35 mm
L/W: 1.823 kg/m



**3000 SERIES
SG PANEL SECTIONS**

SCALE 1:1

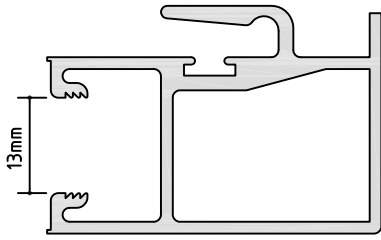

PM 414

STANDARD INTERLOCK
A/P: 264.62 mm
L/W: 0.869 kg/m

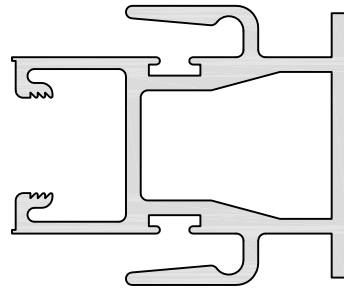

PM 409

DOUBLE INTERLOCK
STILE
A/P: 330.20 mm
L/W: 1.165 kg/m

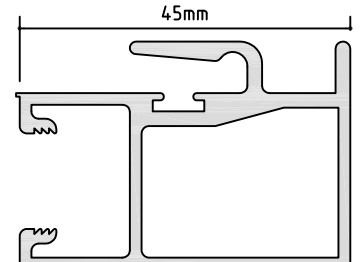

PM 424

66mm INTERLOCK STILE
A/P: 394.68 mm
L/W: 1.723 kg/m

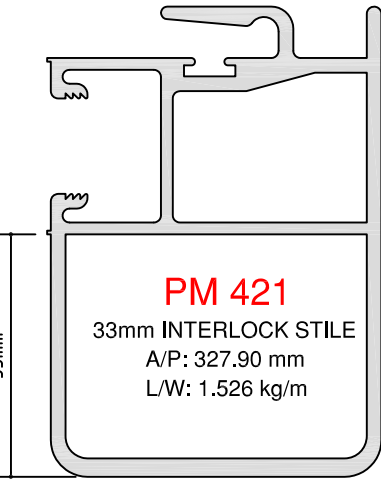

PM 421

33mm INTERLOCK STILE
A/P: 327.90 mm
L/W: 1.526 kg/m

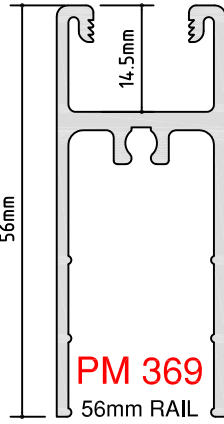

PM 369

56mm RAIL
A/P: 310.58 mm
L/W: 0.735 kg/m

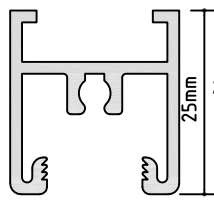

PM 407

25mm TOP RAIL
A/P: 200.17 mm
L/W: 0.438 kg/m

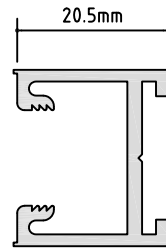

PM 410

21mm STILE
A/P: 167.18mm
L/W: 0.373 kg/m

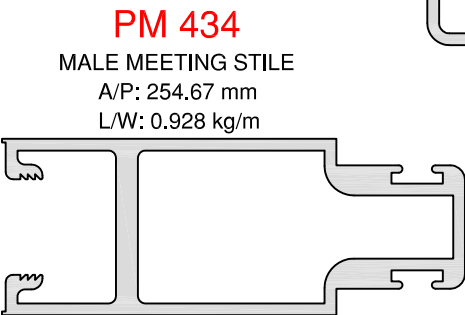
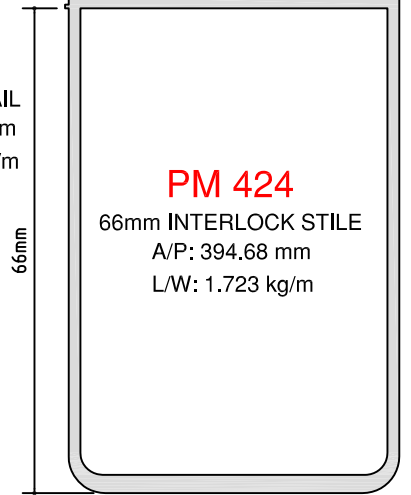

PM 434

MALE MEETING STILE
A/P: 254.67 mm
L/W: 0.928 kg/m

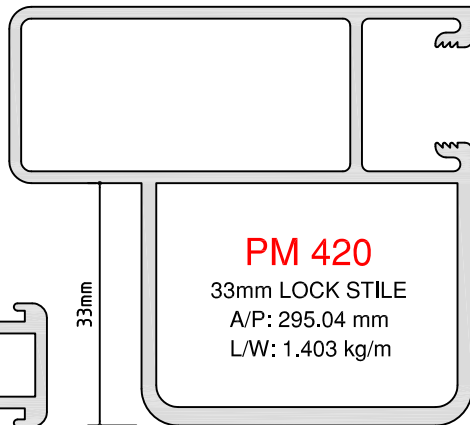

PM 420

33mm LOCK STILE
A/P: 295.04 mm
L/W: 1.403 kg/m

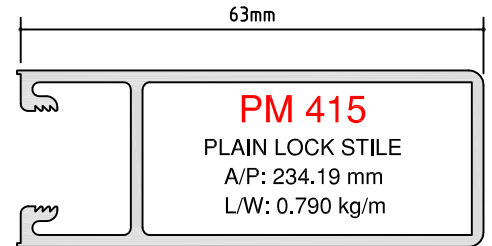

PM 415

PLAIN LOCK STILE
A/P: 234.19 mm
L/W: 0.790 kg/m

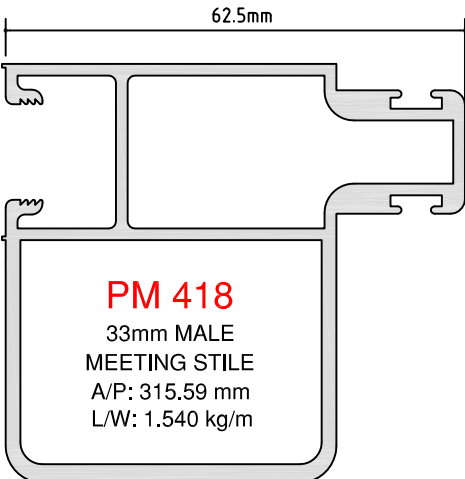

PM 418

33mm MALE
MEETING STILE
A/P: 315.59 mm
L/W: 1.540 kg/m

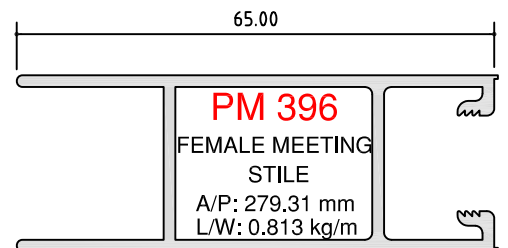

PM 396

FEMALE MEETING
STILE
A/P: 279.31 mm
L/W: 0.813 kg/m

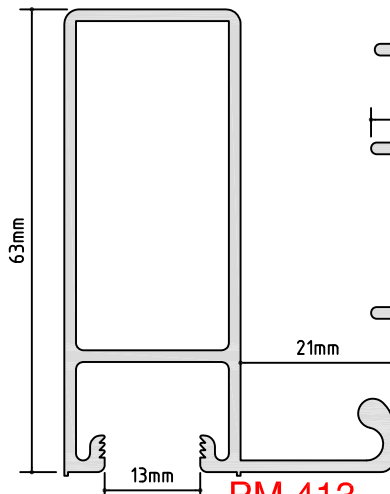

PM 413

HANDLE STILE
A/P: 293.78mm
L/W: 0.944 kg/m

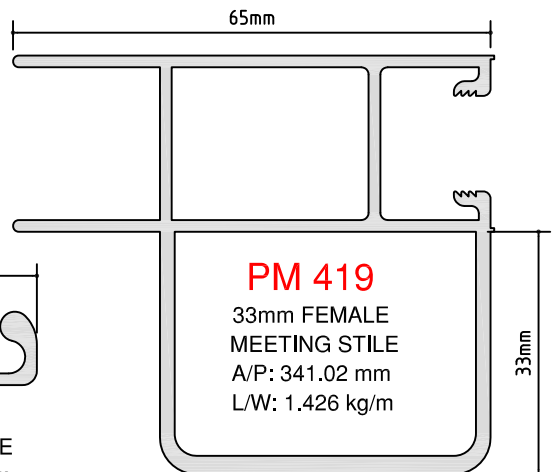

PM 419

33mm FEMALE
MEETING STILE
A/P: 341.02 mm
L/W: 1.426 kg/m



**3000 SERIES
SG PANEL SECTIONS**

SCALE 1:1

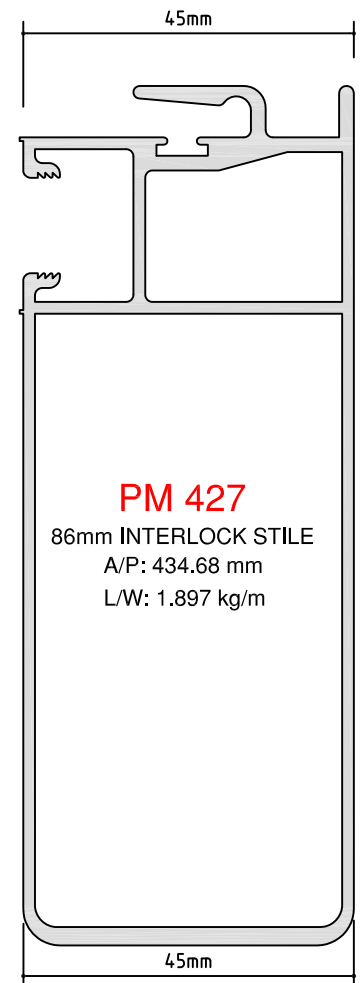
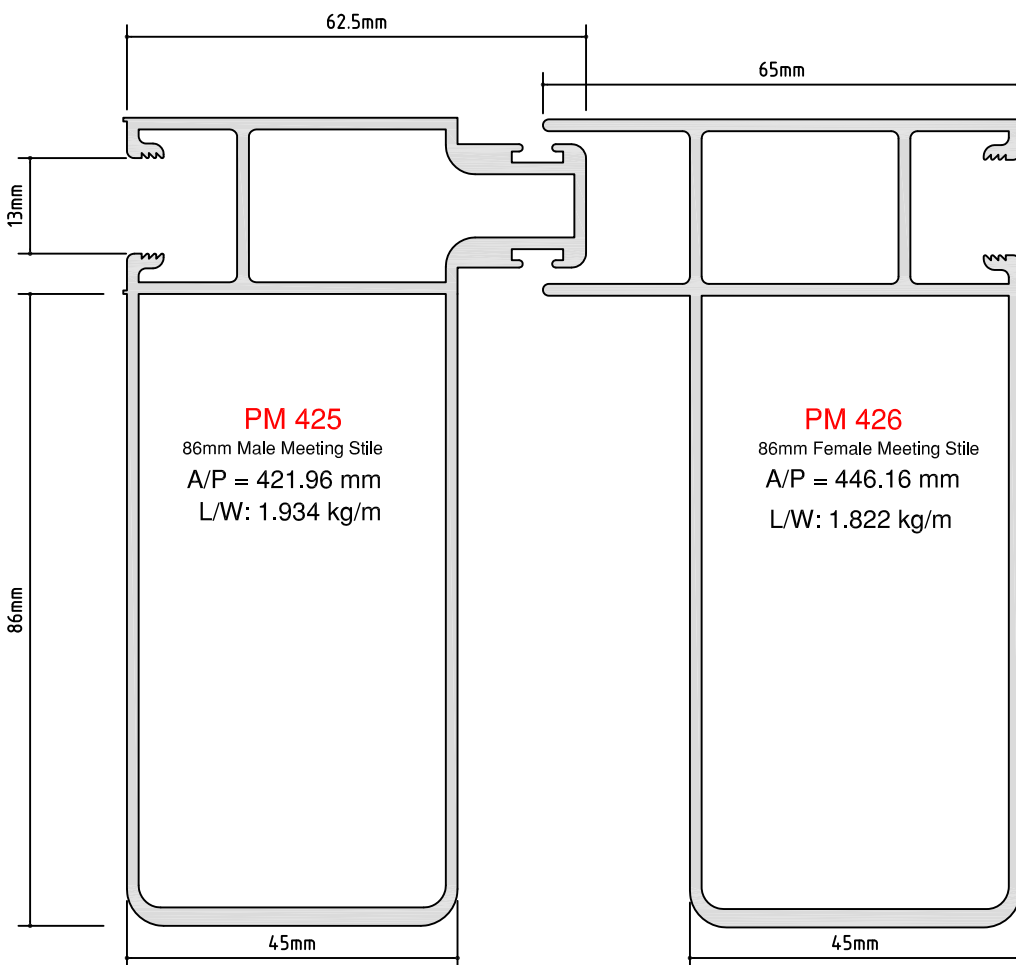
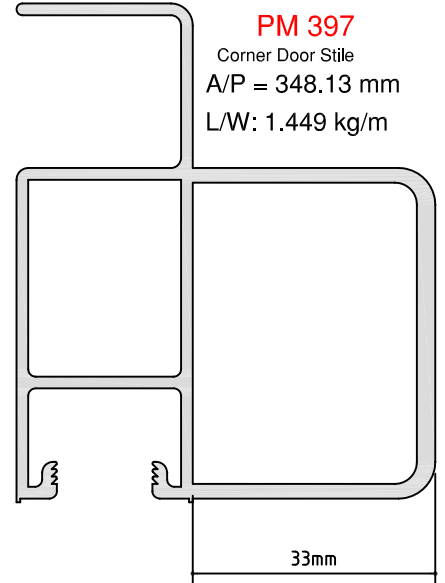
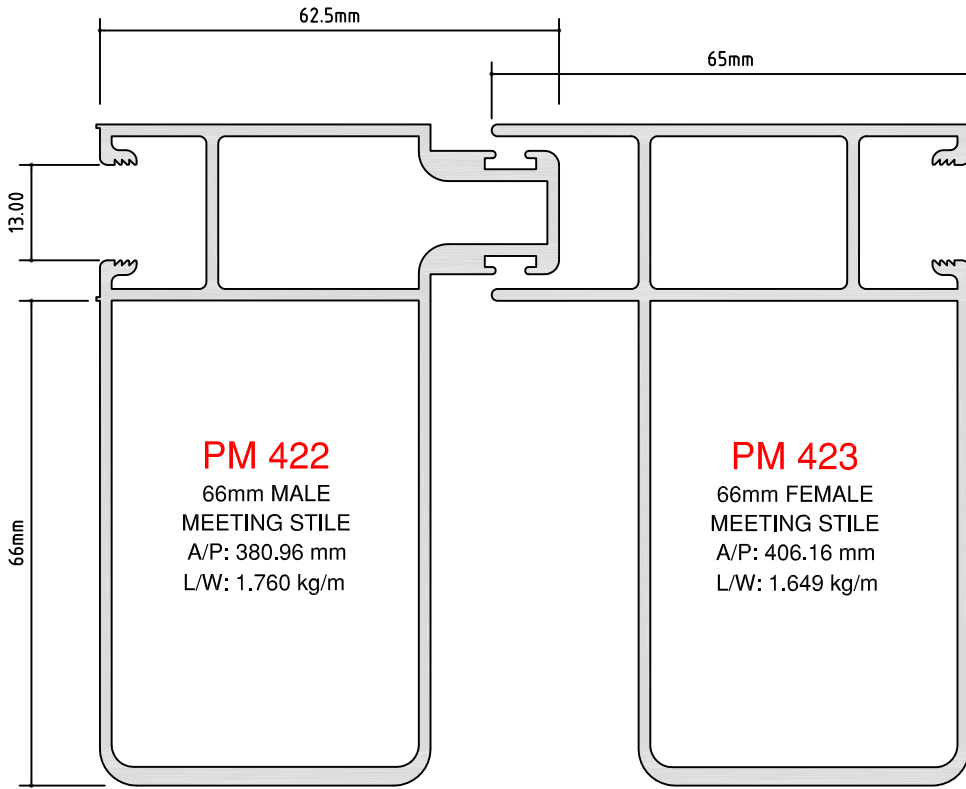

SCALE 1:1

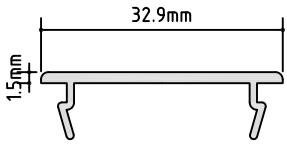

PM 405
PLAIN TRACK INFILL
A/P: 101.34 mm
L/W: 0.179 kg/m

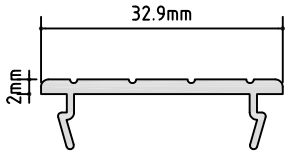

PM 416
TREAD THRESHOLD
A/P: 104.10 mm
L/W: 0.218 kg/m

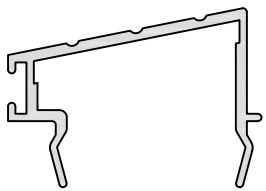

PM 440
RAMPED THRESHOLD
A/P: 172.31 mm
L/W: 0.298 kg/m

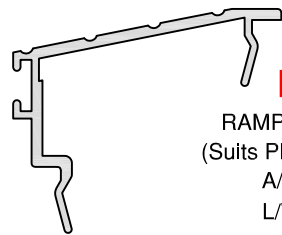

PM 449
RAMPED THRESHOLD
(Suits PM400 High Rise Sill)
A/P: 174.52 mm
L/W: 0.297 kg/m

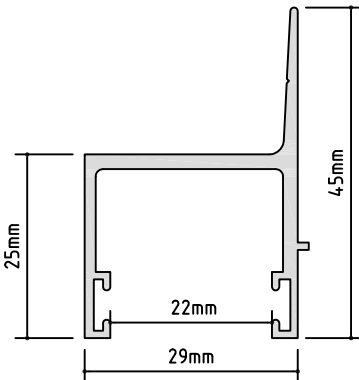

PM 445
SINGLE HEAD TRACK
ADAPTOR
A/P: 221.01 mm
L/W: 0.473 kg/m

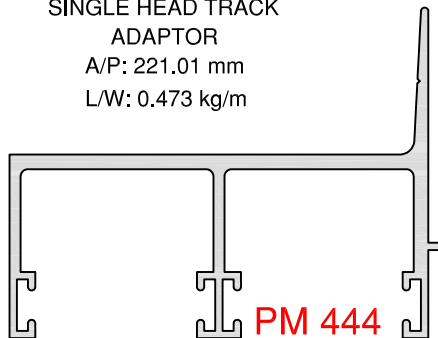

PM 444
DOUBLE HEAD TRACK
ADAPTOR
A/P: 354.33 mm
L/W: 0.740 kg/m

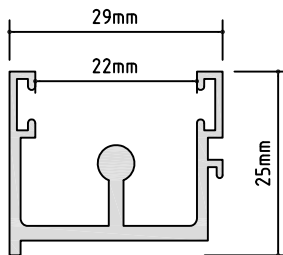

PM 447
SINGLE TRACK ADAPTOR
A/P: 204.15 mm
L/W: 0.438 kg/m

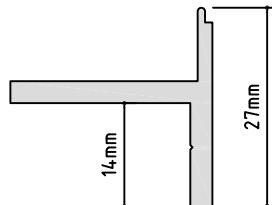

PM 448
TRACK SUPPORT
A/P: 108.82 mm
L/W: 0.385 kg/m

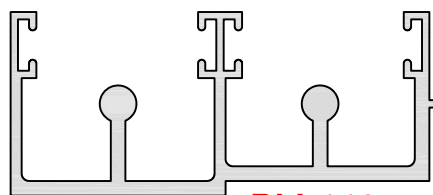

PM 446
DOUBLE TRACK ADAPTOR
A/P: 362.64 mm
L/W: 0.809 kg/m

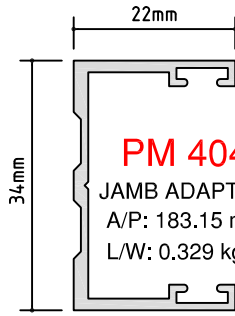

PM 404
JAMB ADAPTOR
A/P: 183.15 mm
L/W: 0.329 kg/m

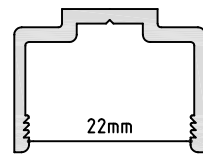

PM 487
18mm GLAZING
ADAPTOR
A/P: 130.32 mm
L/W: 0.296 kg/m

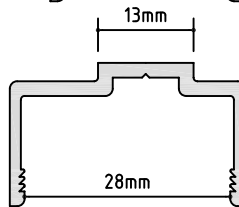

PM 488
24mm GLAZING
ADAPTOR
A/P: 142.32 mm
L/W: 0.328 kg/m

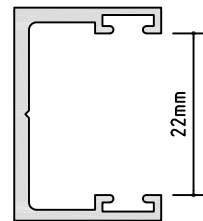

PM740
SCREEN DOOR
CHANNEL
A/P: 161.54 mm
L/W: 0.336 kg/m

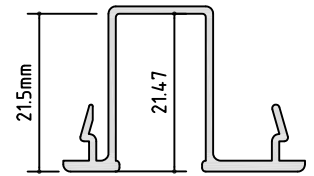

PM 755
SCREEN ADAPTOR
A/P: 184.12 mm
L/W: 0.276 kg/m

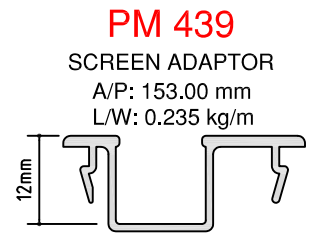

PM 439
SCREEN ADAPTOR
A/P: 153.00 mm
L/W: 0.235 kg/m

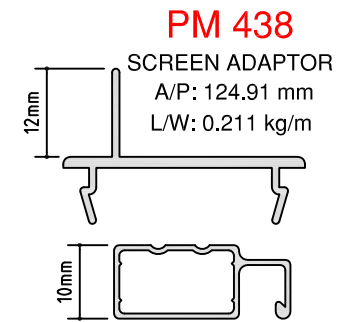

PM 438
SCREEN ADAPTOR
A/P: 124.91 mm
L/W: 0.211 kg/m

FLE0952
FLY SCREEN FRAME
A/P: 82.90 mm
L/W: 0.134 kg/m

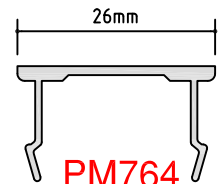

PM764
67mm
DG POCKET FILLER
A/P: 113.88 mm
L/W: 0.185 kg/m

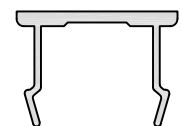

PM116
POCKET FILLER
A/P: 104.23 mm
L/W: 0.177 kg/m



**6000 SERIES
FIXED & ADJUSTABLE LOUVRES**

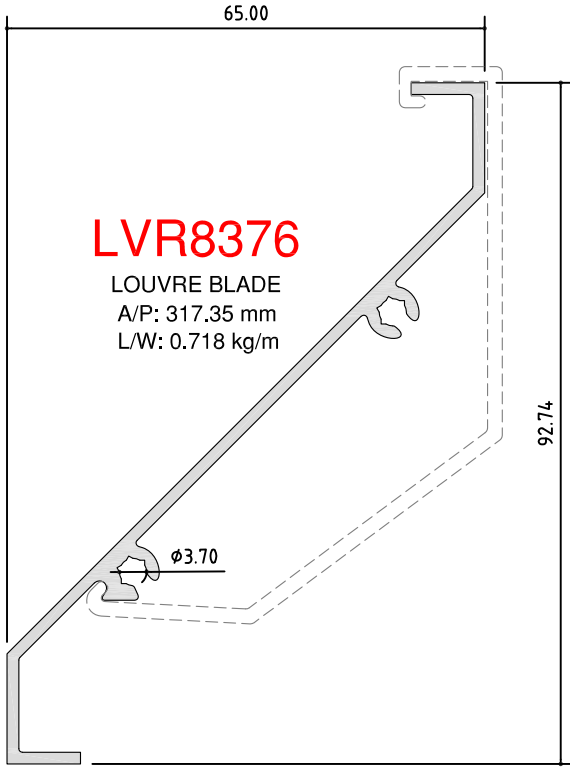

SCALE 1:1

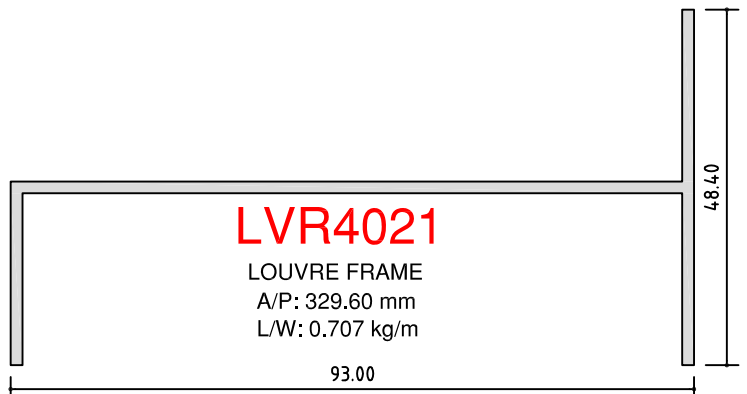
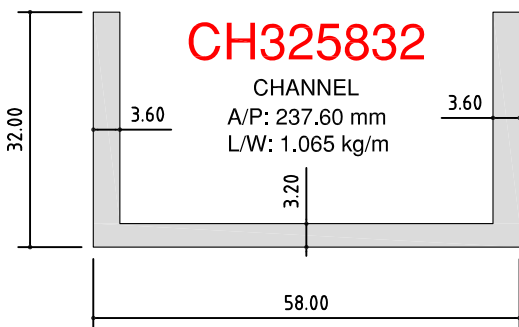
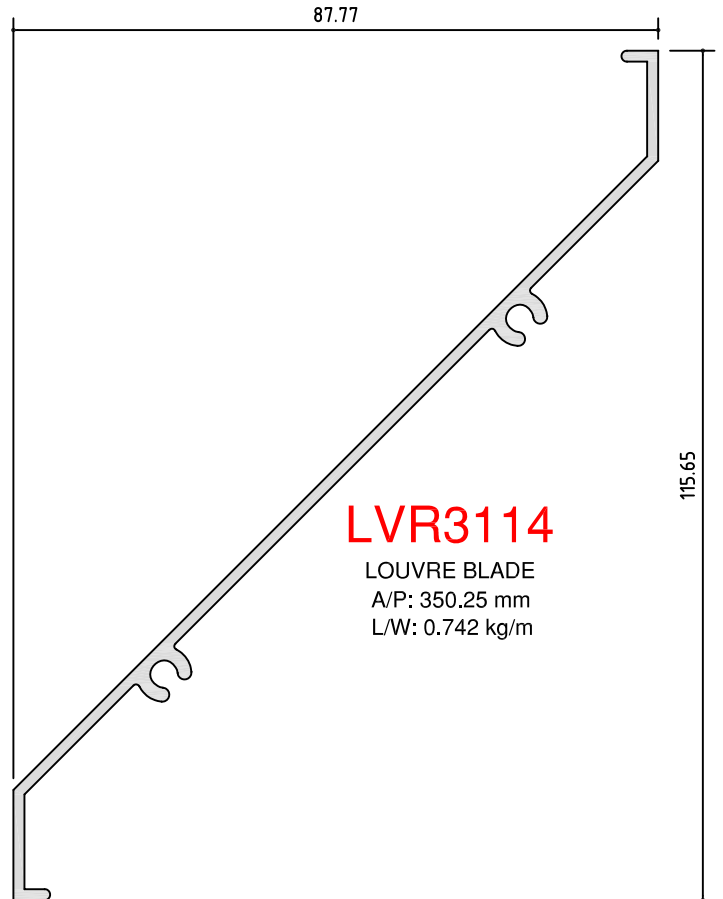
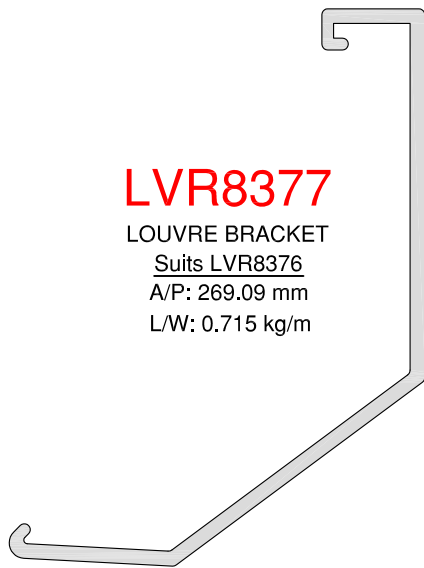
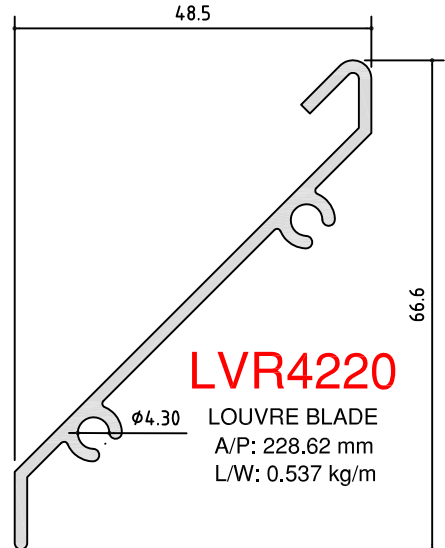

**6000 SERIES
FIXED & ADJUSTABLE LOUVRES**

SCALE 1:1

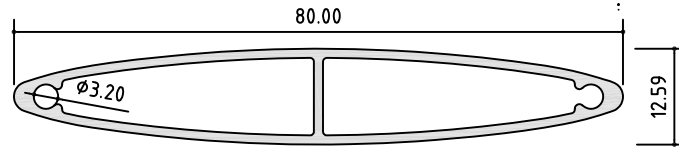

PM622
LOUVRE BLADE
A/P: 166.06 mm
L/W: 0.587 kg/m

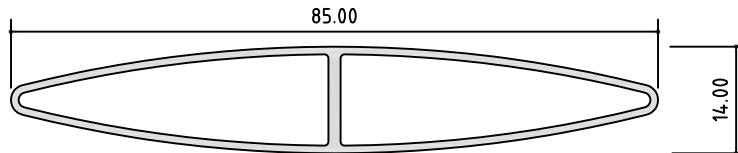

LVR51532
LOUVRE BLADE
A/P: 176.21 mm
L/W: 0.522 kg/m

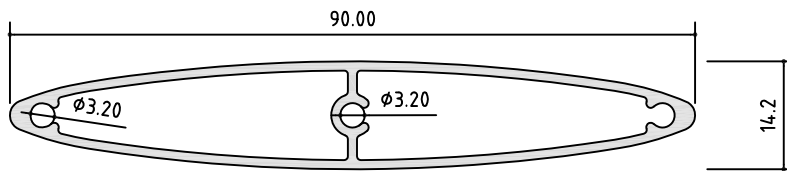

LVR3213
LOUVRE BLADE
A/P: 186.51 mm
L/W: 0.687 kg/m

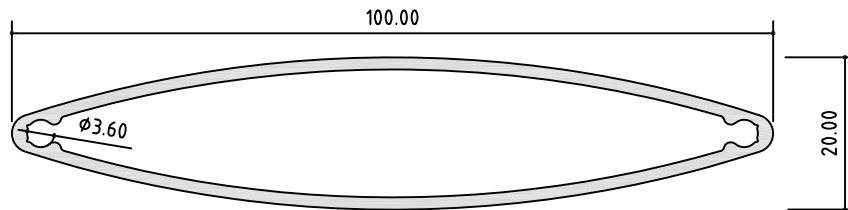

LVR50837
LOUVRE BLADE
A/P: 208.85 mm
L/W: 0.887 kg/m

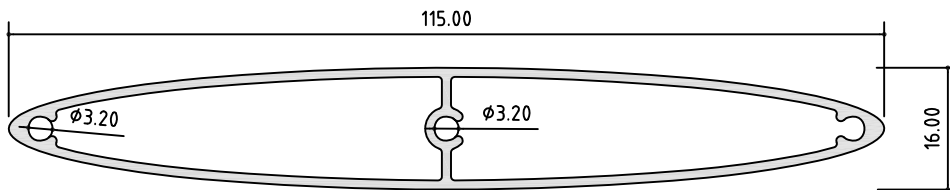

LVR3214
LOUVRE BLADE
A/P: 236.40 mm
L/W: 0.849 kg/m

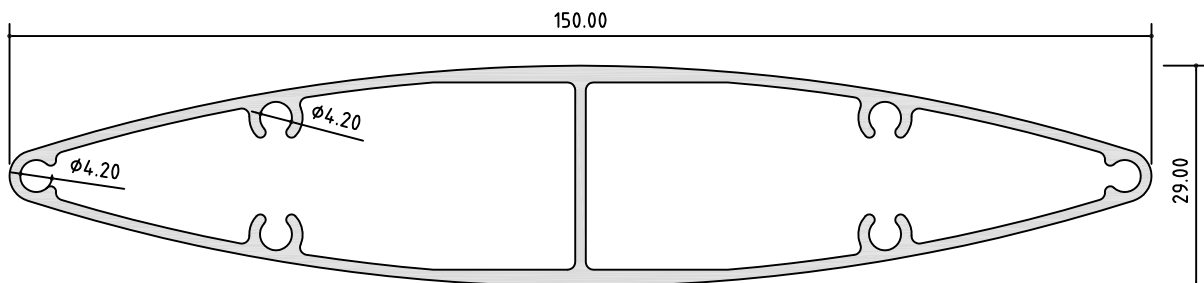

LVR20031
LOUVRE BLADE
A/P: 312.32 mm
L/W: 1.557 kg/m

**6000 SERIES
FIXED & ADJUSTABLE LOUVRES**

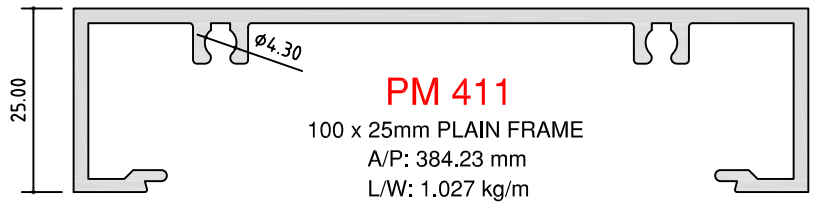
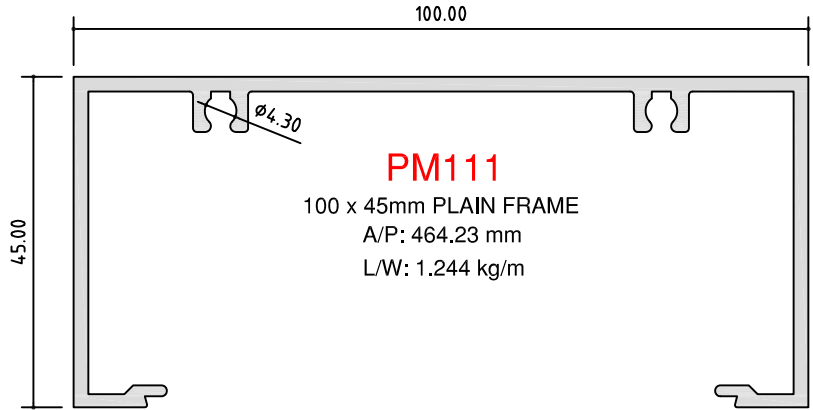
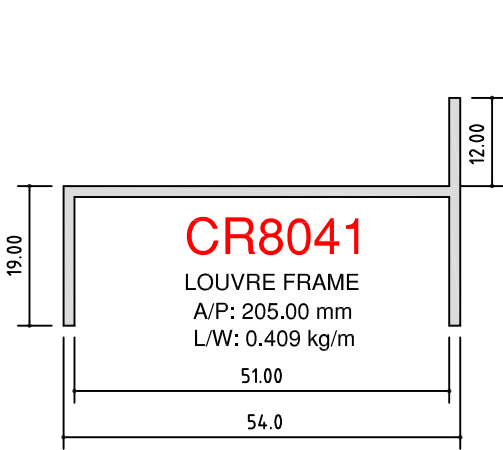

SCALE 1:1

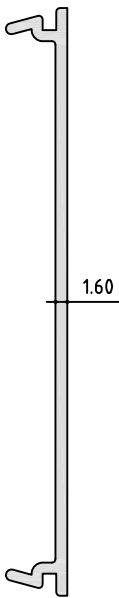

PM 105
100mm FLAT INFILL
A/P: 202.91 mm
L/W: 0.430 kg/m

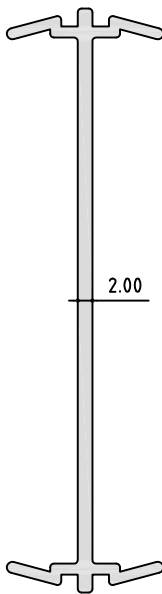

PM 114
100mm FRAME
COUPLER
A/P: 245.89
L/W: 0.609 kg/m

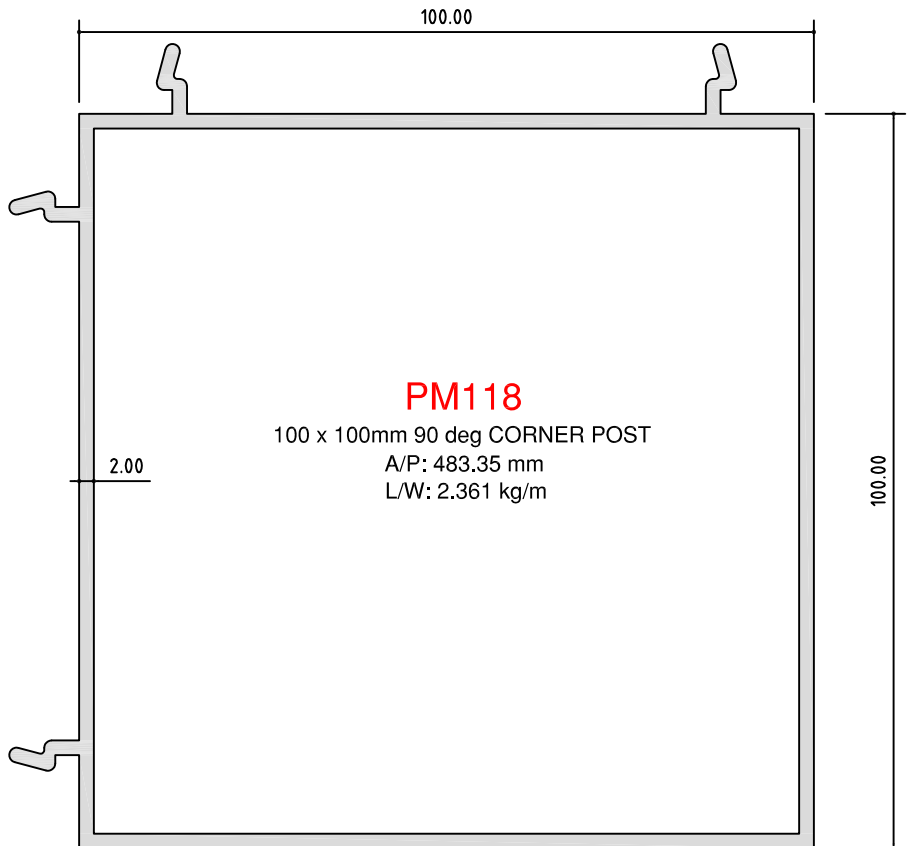

**6000 SERIES
FIXED & ADJUSTABLE LOUVRES**

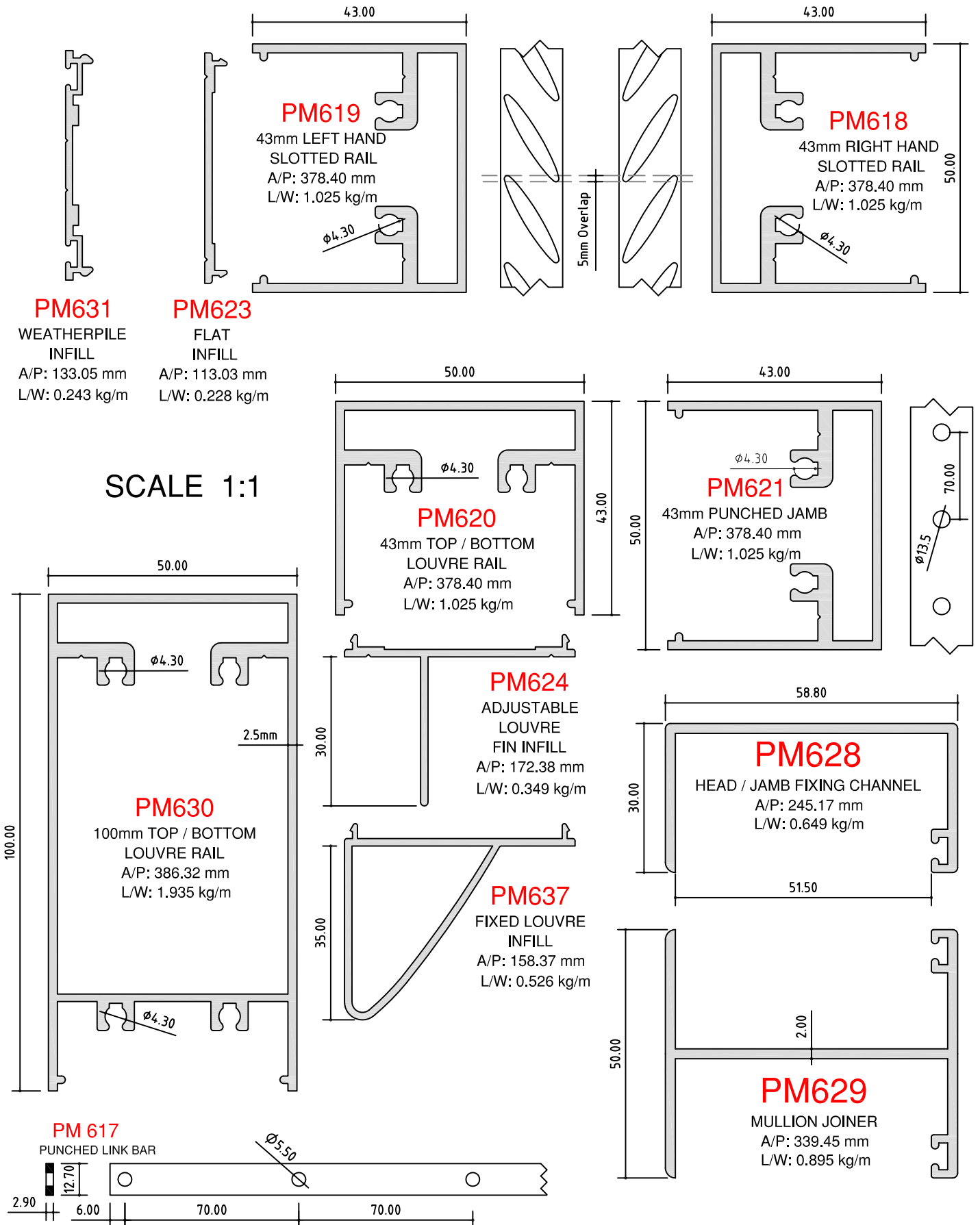

6000 SERIES
FIXED & ADJUSTABLE LOUVRES

SCALE 1:1

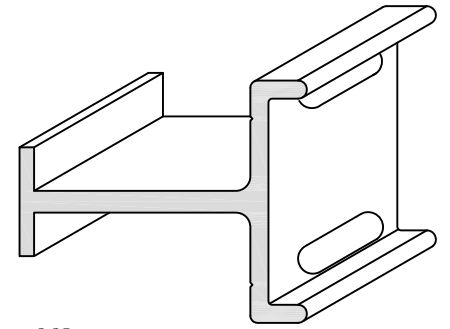

PM632
STIFFENER

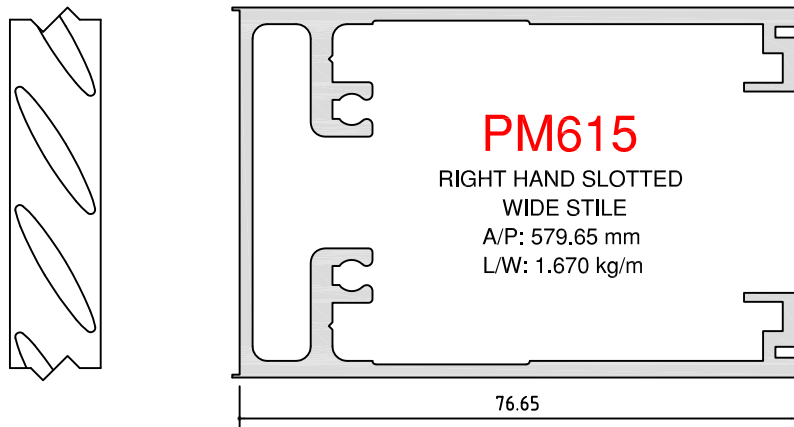
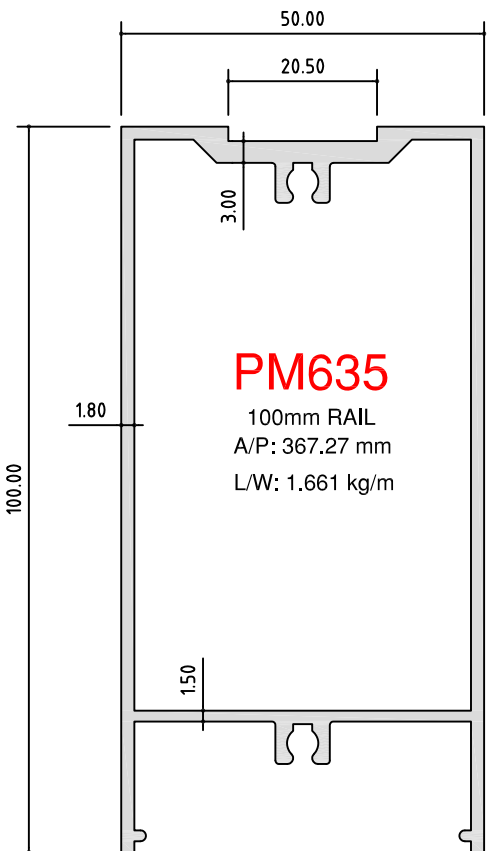
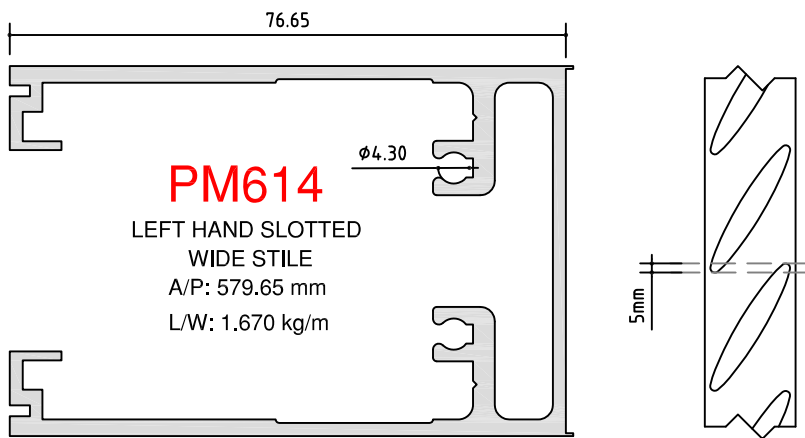
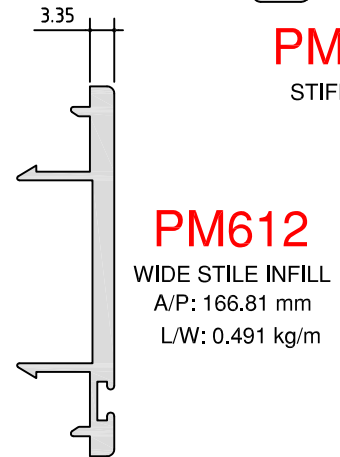
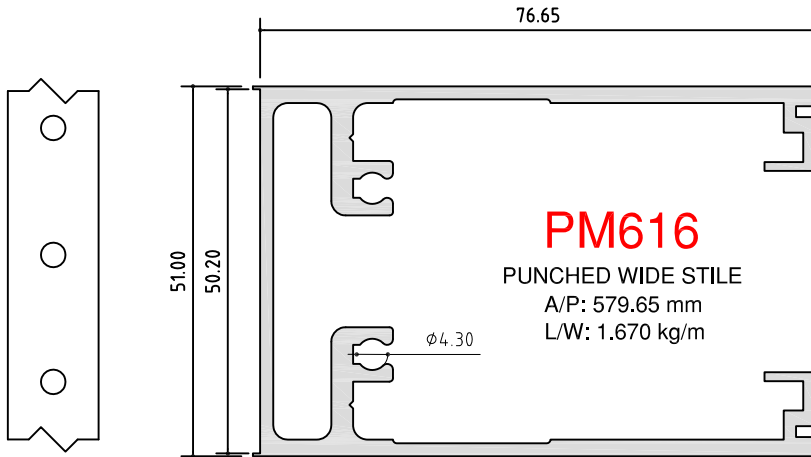



**6000 SERIES
FIXED & ADJUSTABLE LOUVRES**

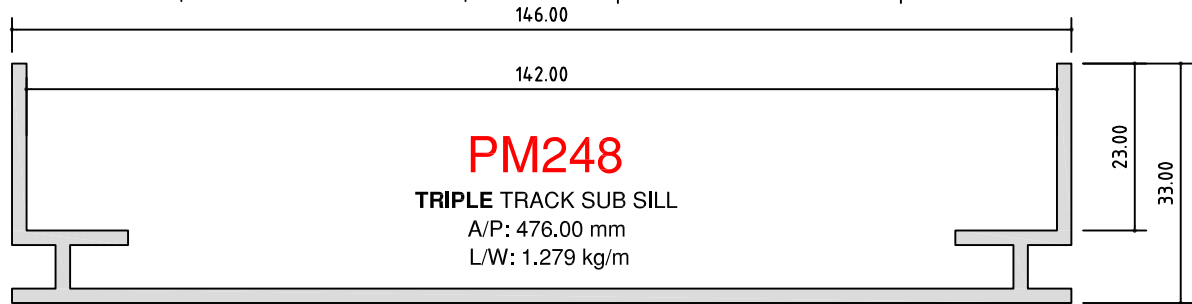
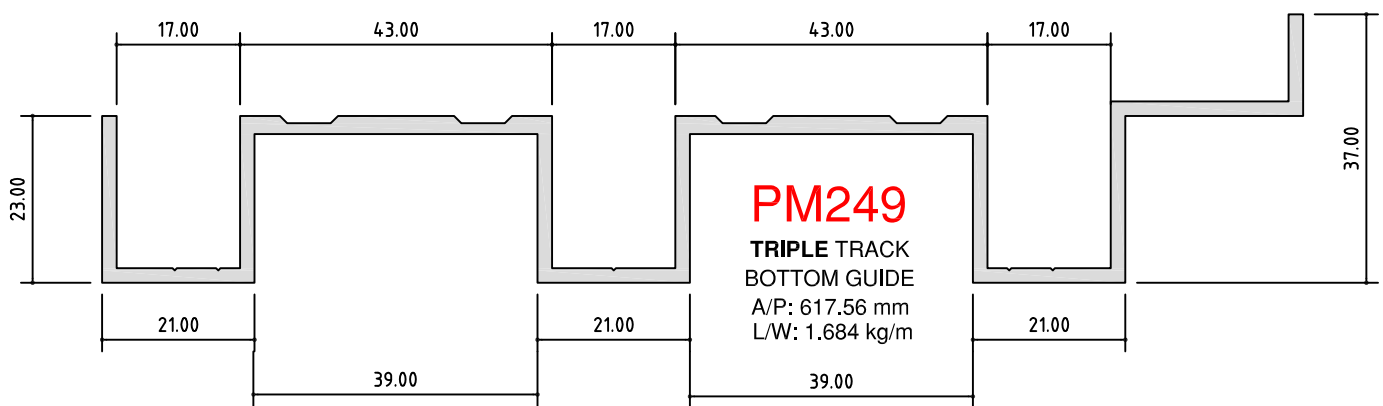
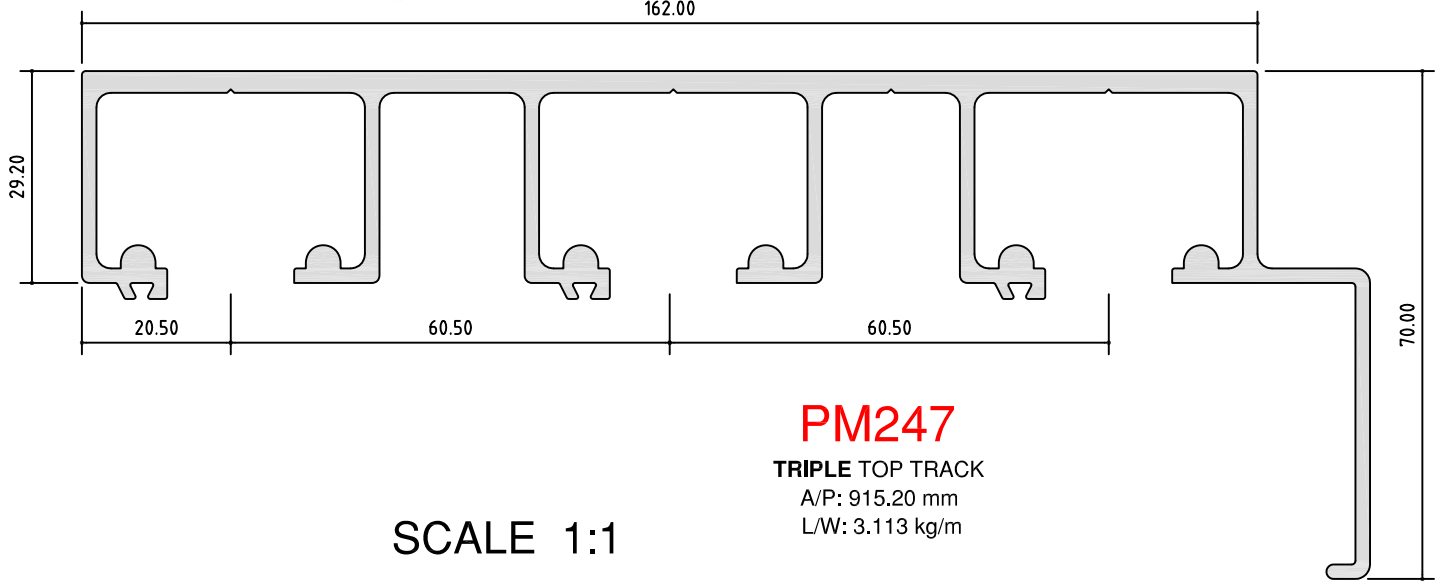
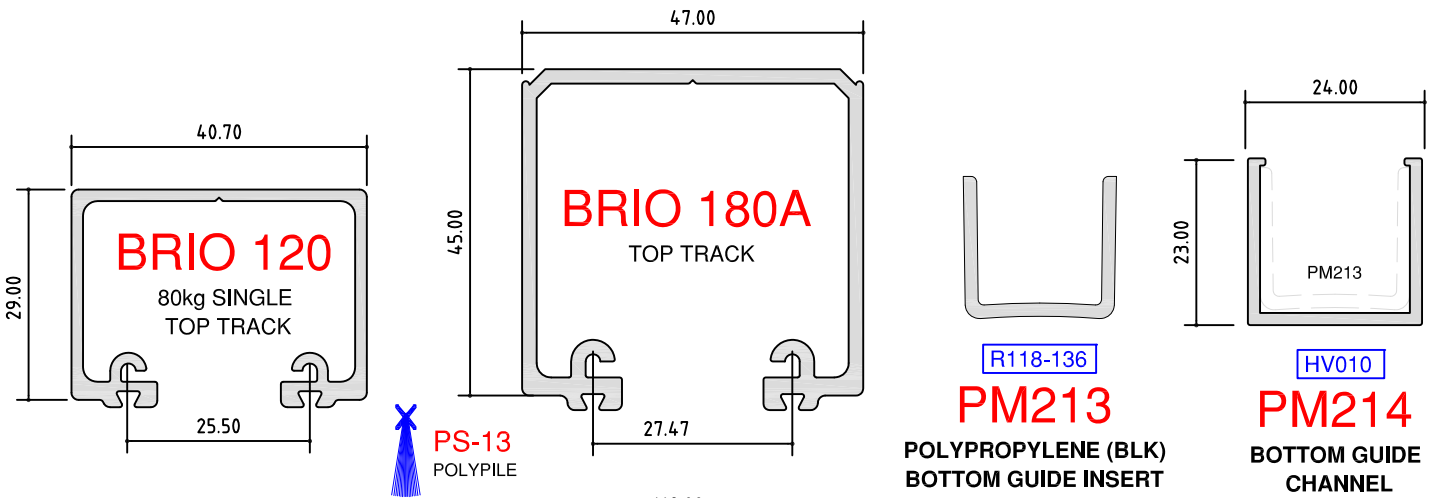

**6000 SERIES
FIXED & ADJUSTABLE LOUVRES**

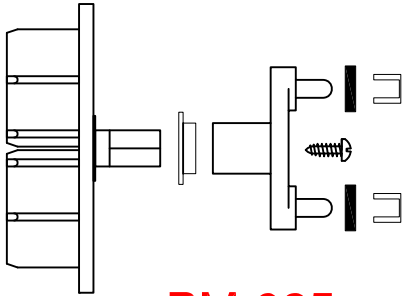

PM 625

BLADE OPERATOR SET

1 Required each adjustable blade

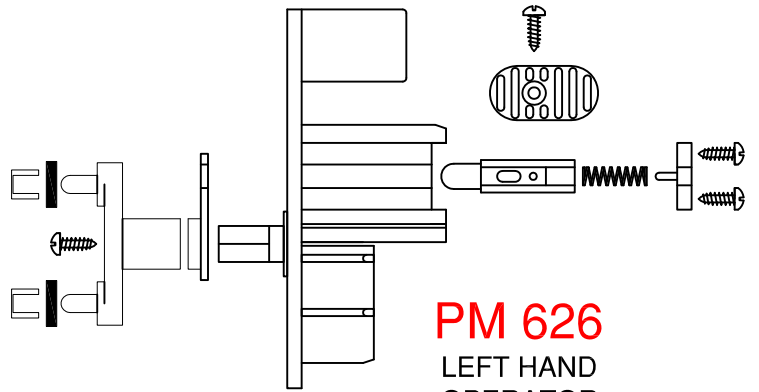

PM 626

LEFT HAND OPERATOR

Required each locking / operation blade
(Recommended 15 blades to 1 operator)

LIST OF PARTS

- P1 x 2
- P2 x 2
- P3 x 2
- P4 x 1

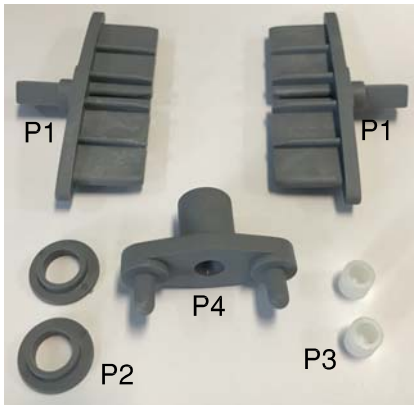

LIST OF PARTS

- P1 x 1
- P2 x 1
- P3 x 2
- P4 x 1
- P5 x 1
- P6 x 1
- P7 x 1
- P8 x 1
- P9 x 1
- P10 x 1
- P11 x 3



PM610

END CAP
(Optional)



PM632

CORNER STIFFENER
1 Required each frame corner joint

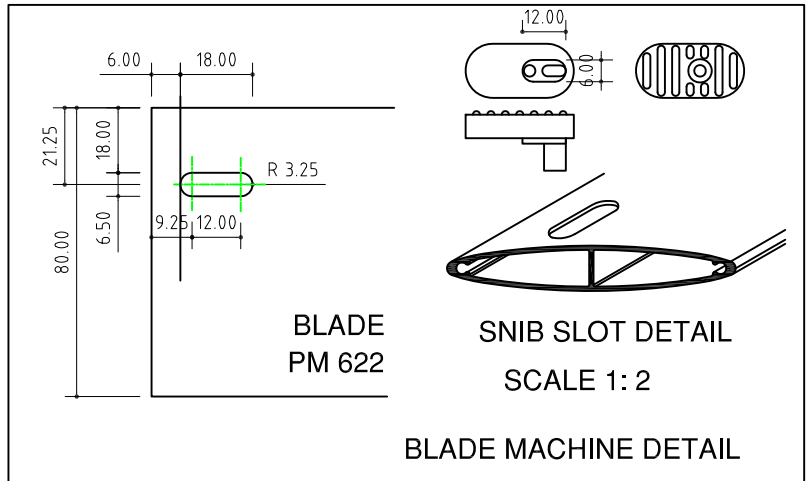

**7000 SERIES
BI-FOLDING WINDOWS & DOORS**

SCALE 1:1

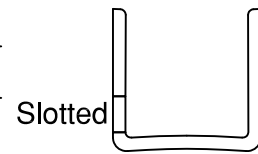
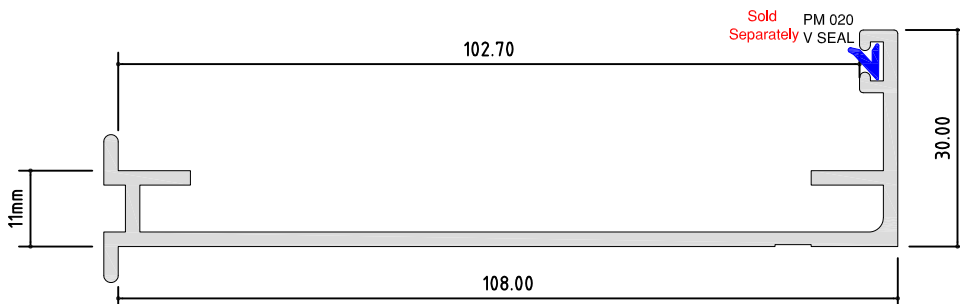
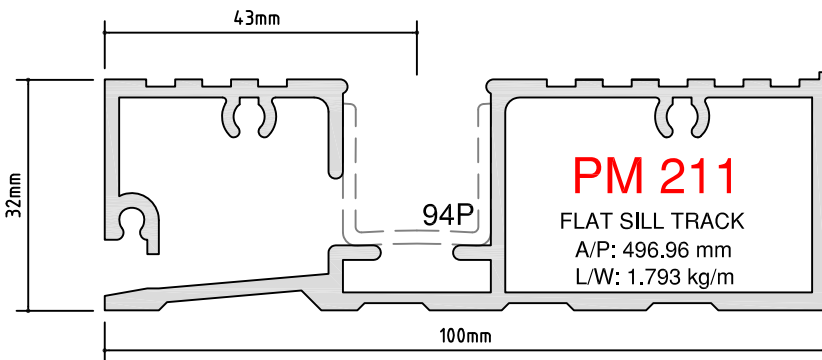
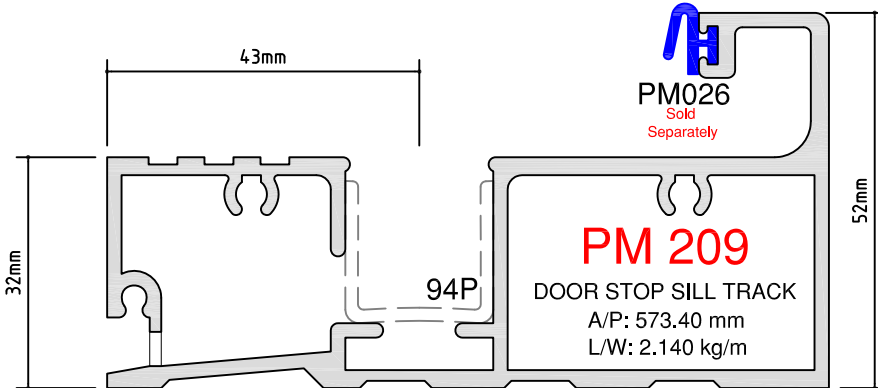
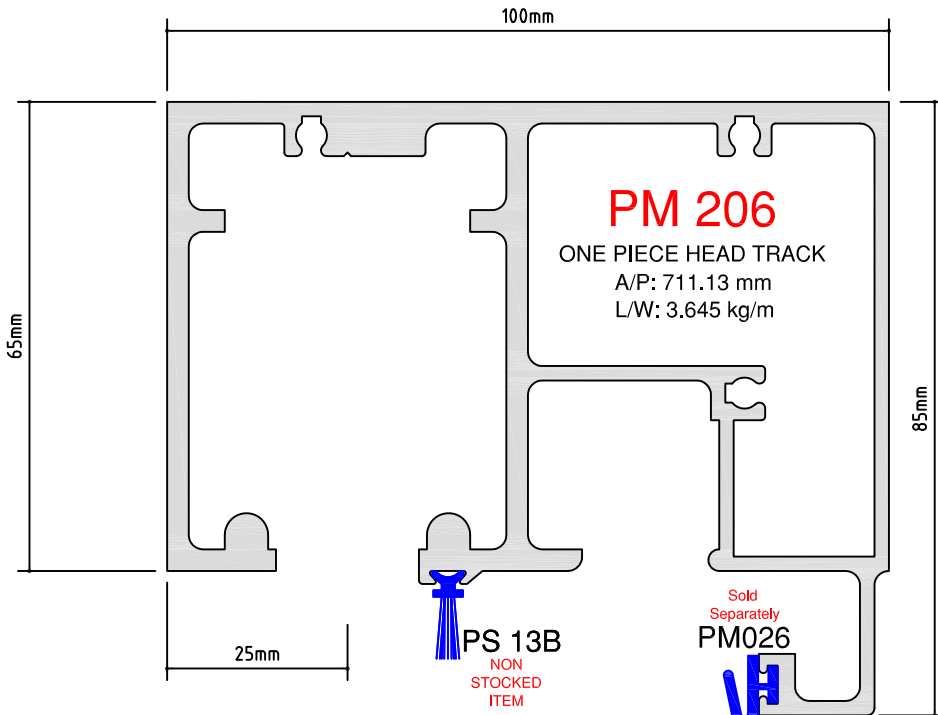

PM213 (94P)
POLYPROPYLENE CHANNEL INFILL
Suits
(PM207 / PM209 / PM211 / PM214)

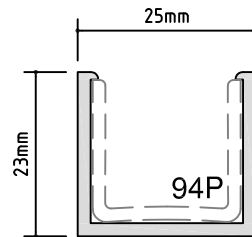

PM214
CHANNEL
A/P: 140.15 mm
L/W: 0.331 kg/m



7000 SERIES BI-FOLDING WINDOWS & DOORS

SCALE 1:1

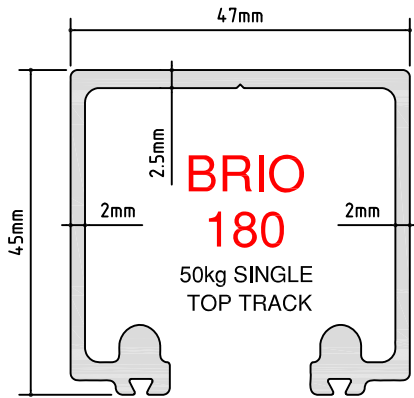

NON STOCKED ITEM

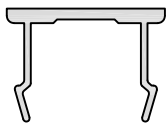

PMA6299
PM 116
POCKET FILLER
A/P: 104.23 mm
L/W: 0.177 kg/m

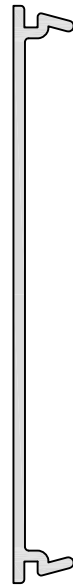

PMA6169
PM 105
100mm FLAT INFILL
A/P: 202.91 mm
L/W: 0.430 kg/m

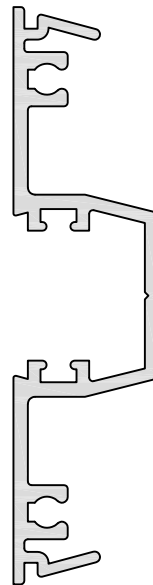
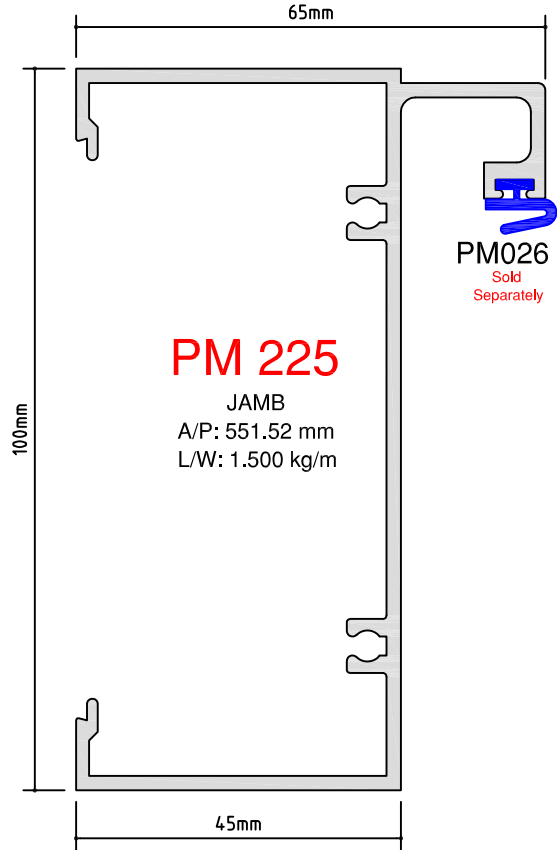

PMA5987
PM 110
GLAZING ADAPTOR
A/P: 345.65 mm
L/W: 0.865 kg/m

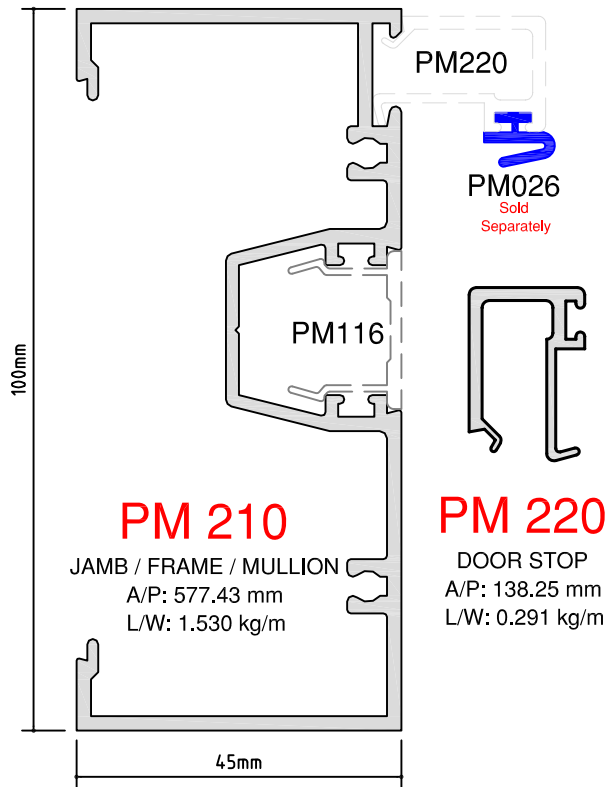



7000 SERIES BI-FOLDING WINDOWS & DOORS

SCALE 1:1

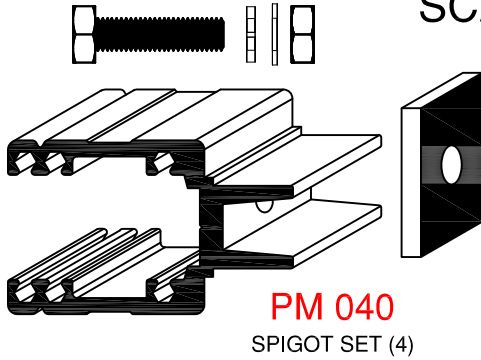

PM 040
SPIGOT SET (4)

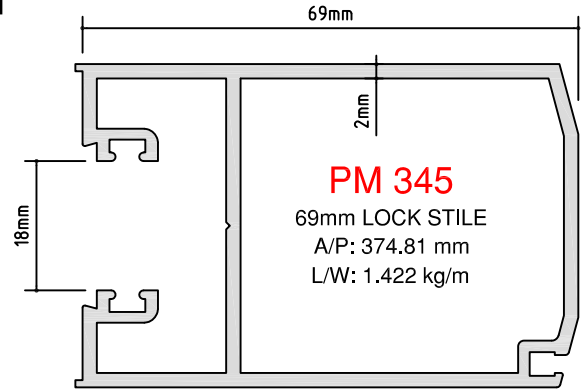

PM 345
69mm LOCK STILE
A/P: 374.81 mm
L/W: 1.422 kg/m

Sold Separately
PM017

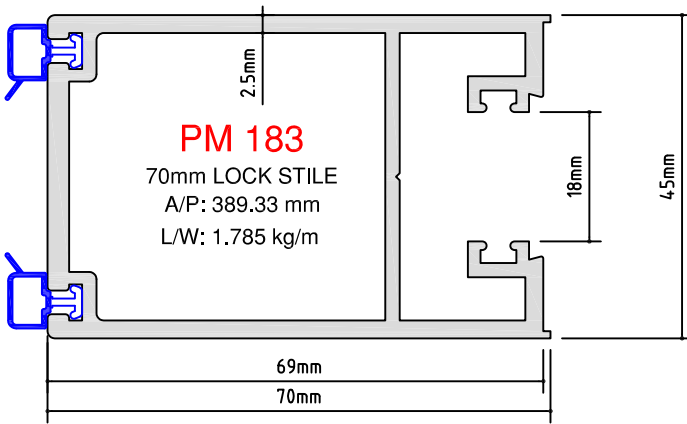

PM 183
70mm LOCK STILE
A/P: 389.33 mm
L/W: 1.785 kg/m

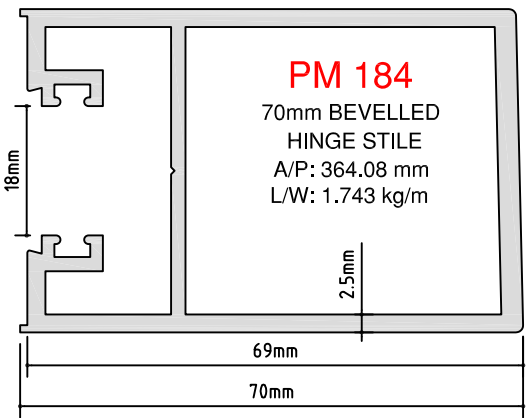

PM 184
70mm BEVELLED
HINGE STILE
A/P: 364.08 mm
L/W: 1.743 kg/m

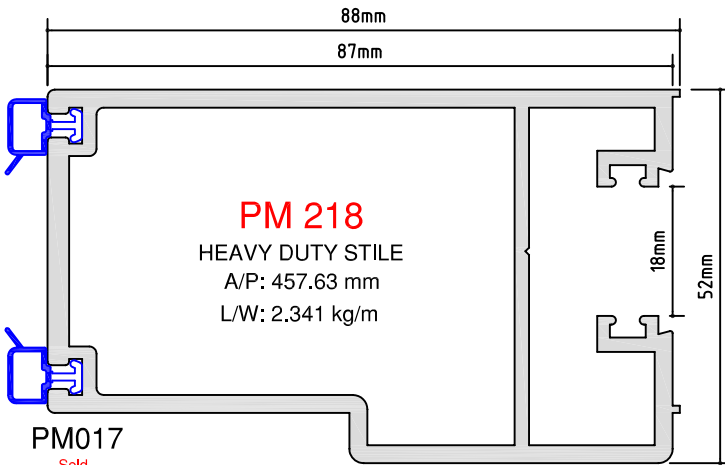

PM 218
HEAVY DUTY STILE
A/P: 457.63 mm
L/W: 2.341 kg/m

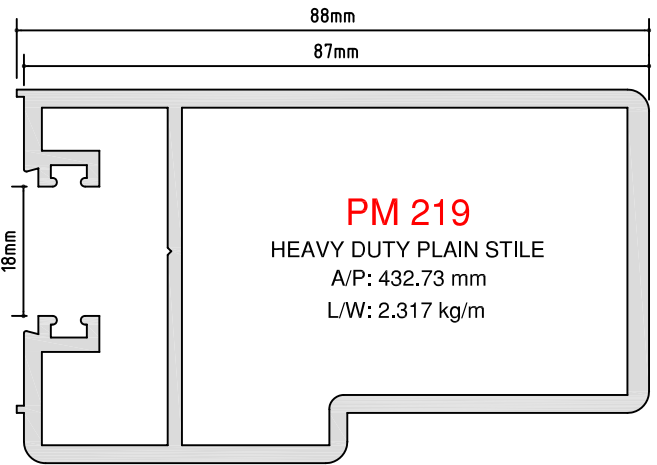

PM 219
HEAVY DUTY PLAIN STILE
A/P: 432.73 mm
L/W: 2.317 kg/m

Sold Separately
PM017

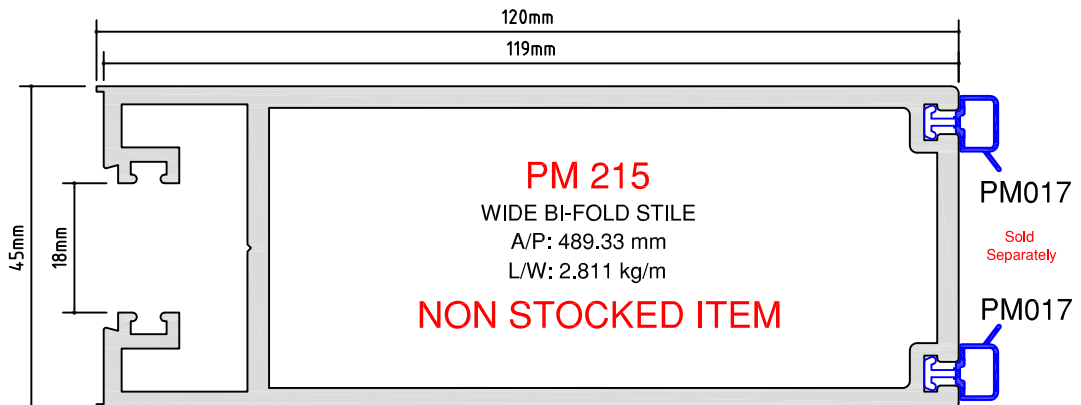

PM 215
WIDE BI-FOLD STILE
A/P: 489.33 mm
L/W: 2.811 kg/m
NON STOCKED ITEM

Sold Separately
PM017

Sold Separately
PM017



**7000 SERIES
BI-FOLDING WINDOWS & DOORS**

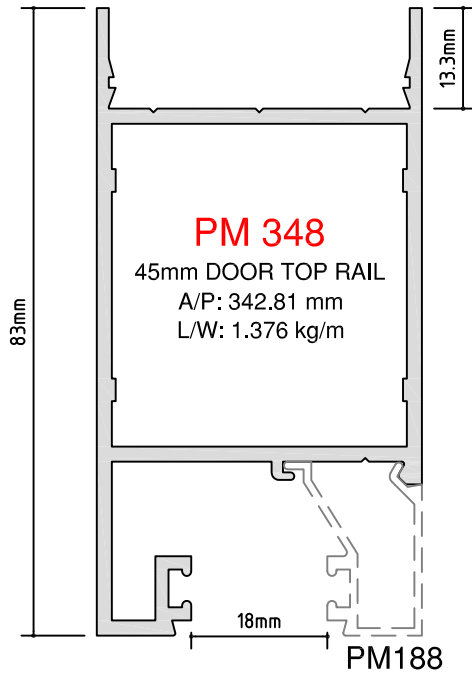

SCALE 1:1

PM 188
DOOR RAIL BEAD
A/P: 135.16 mm
L/W: 0.203 kg/m

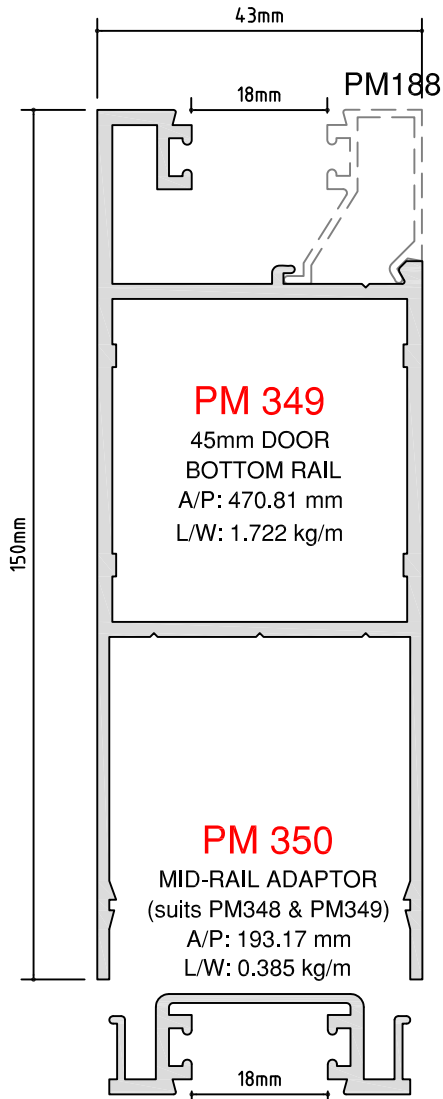
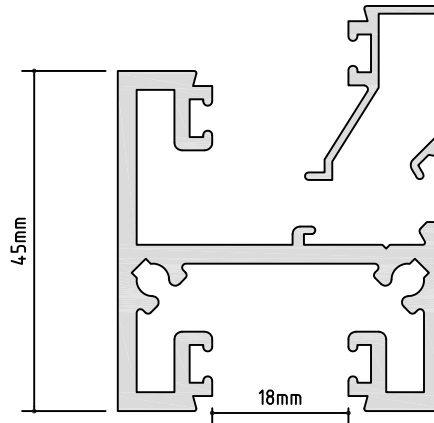

PM 193
45mm DOOR MID-RAIL
A/P: 379.44 mm
L/W: 1.190 kg/m



**7000 SERIES
BI-FOLDING WINDOWS & DOORS**

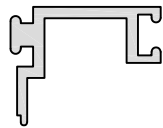
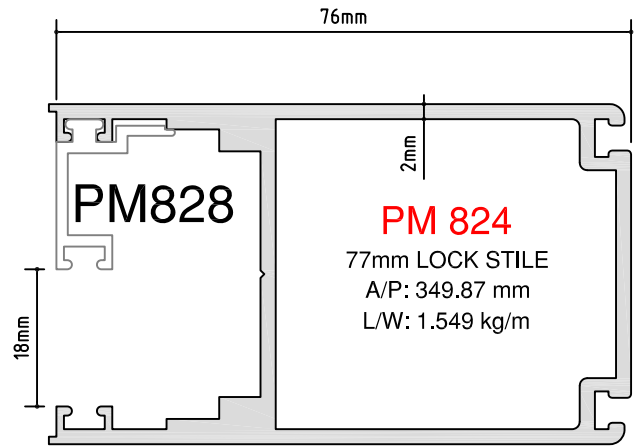
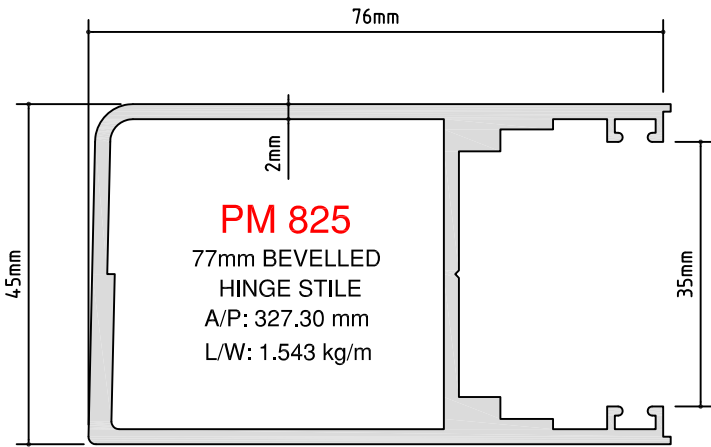

PM 828
SG ADAPTOR
A/P: 98.53 mm
L/W: 0.195 kg/m

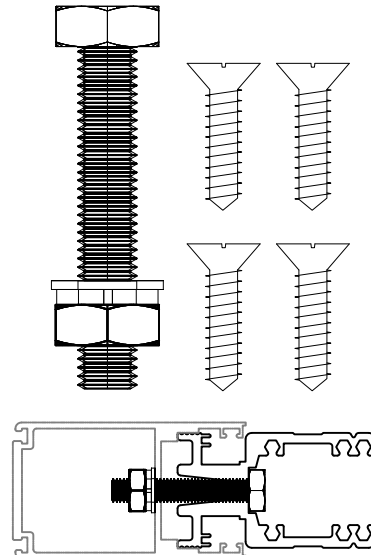
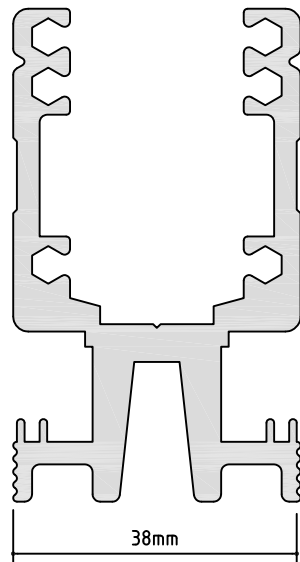
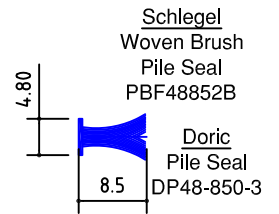

PM 829
SPIGOT SET



**7000 SERIES
BI-FOLDING WINDOWS & DOORS**

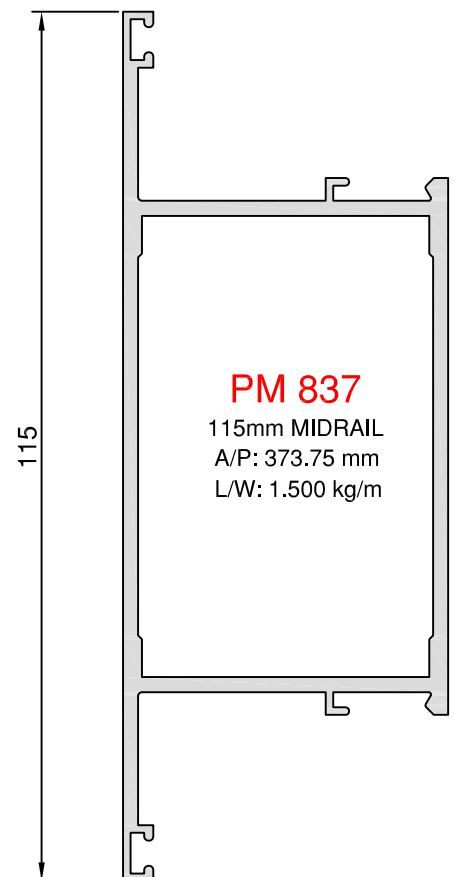
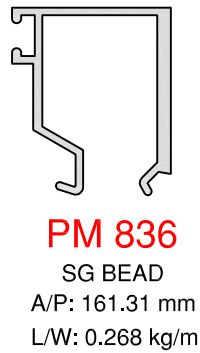
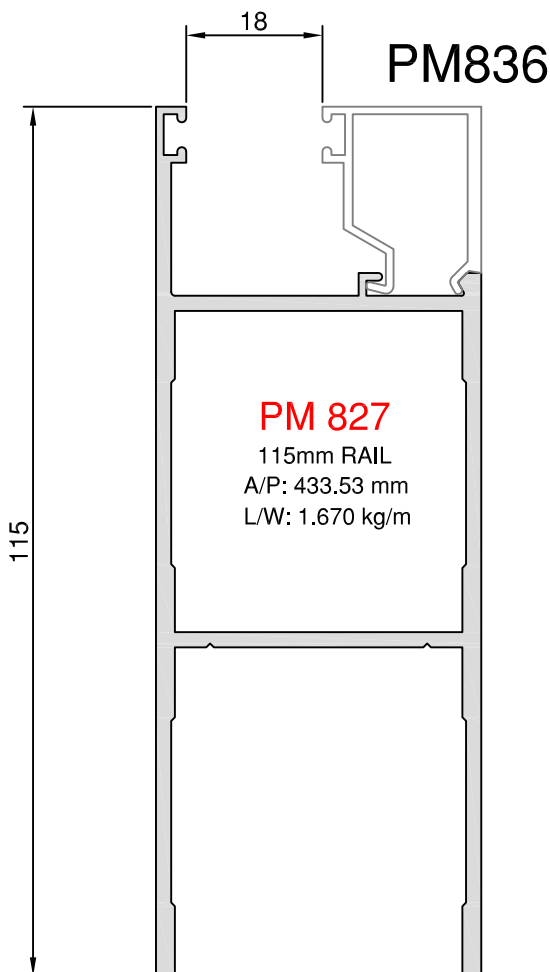
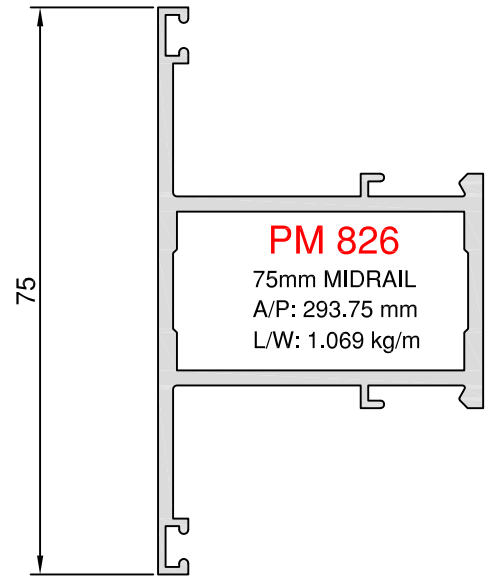
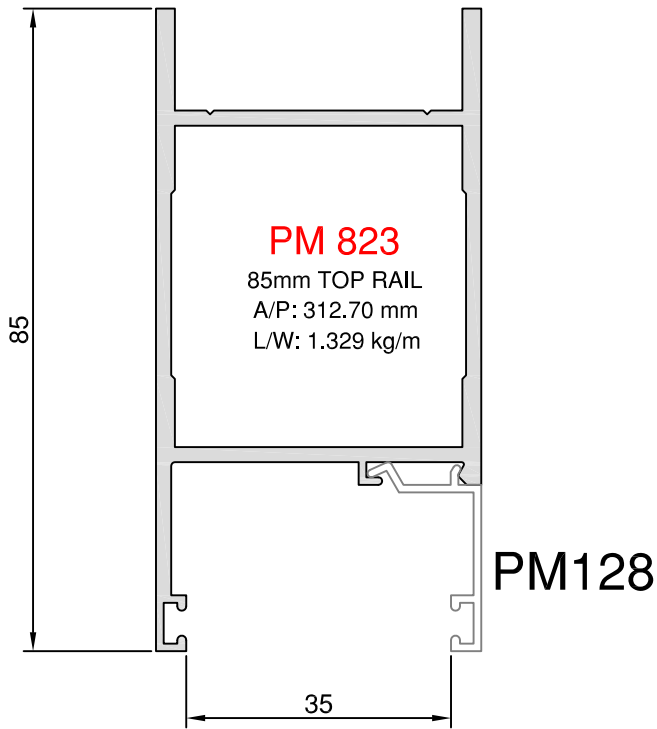



**8000 SERIES
100mm FRAME**

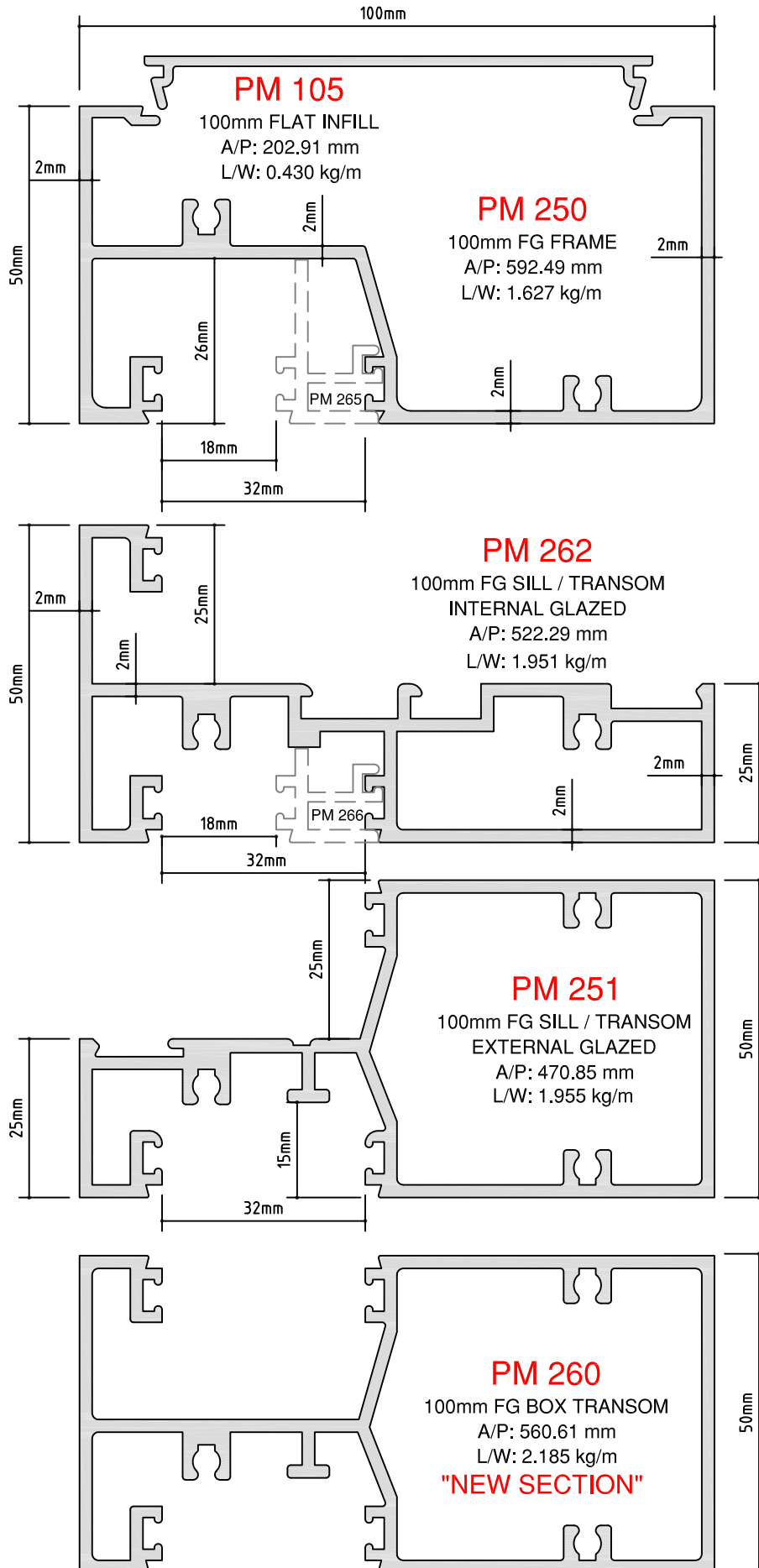

SCALE 1:1

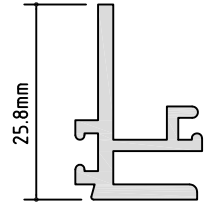

PM 265
LONG LEG
SINGLE GLAZING ADAPTOR
A/P: 125.95 mm
L/W: 0.304 kg/m

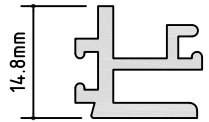

PM 266
SHORT LEG
SINGLE GLAZING ADAPTOR
A/P: 103.95 mm
L/W: 0.245 kg/m

SCALE 1:1

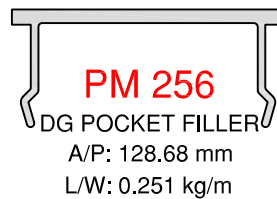
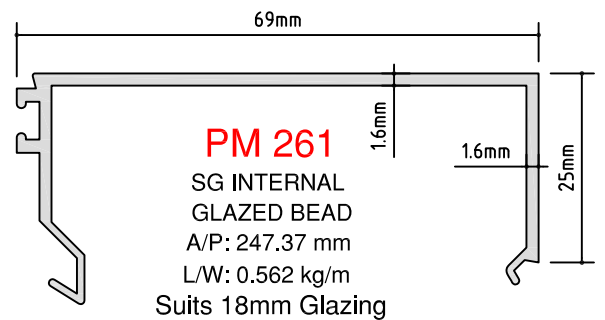
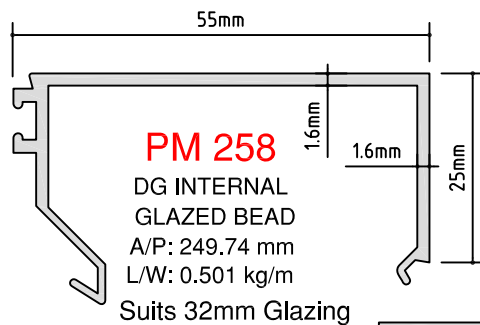
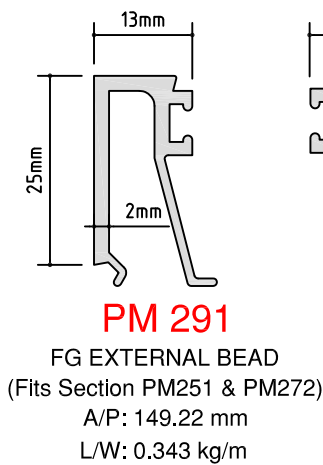
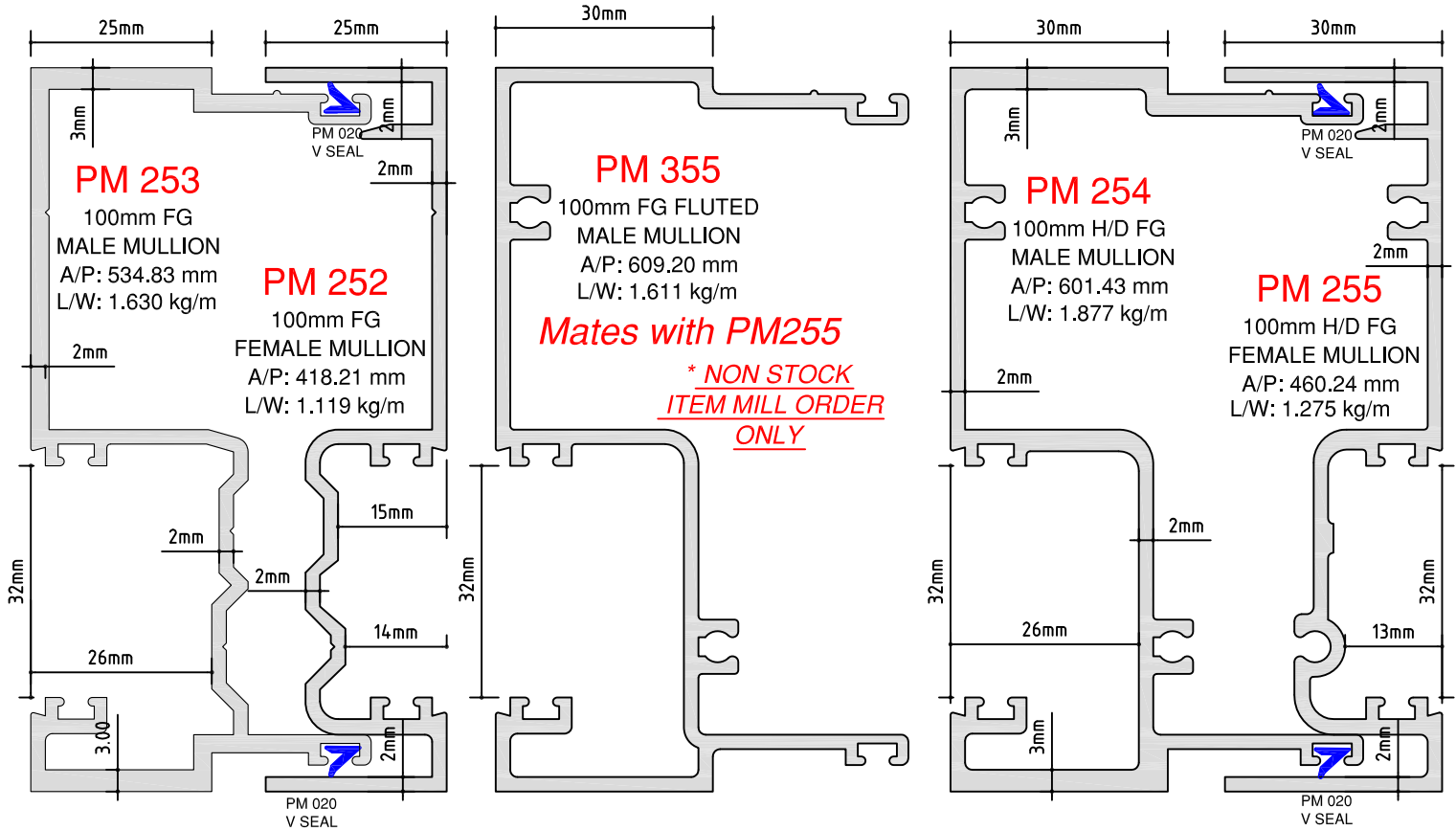



**8000 SERIES
150mm FRAME**

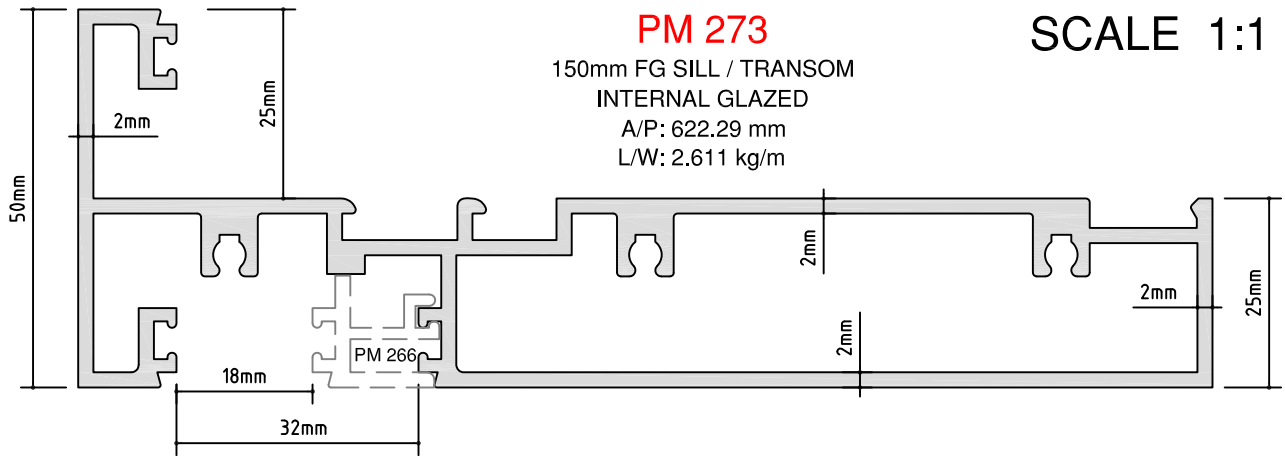
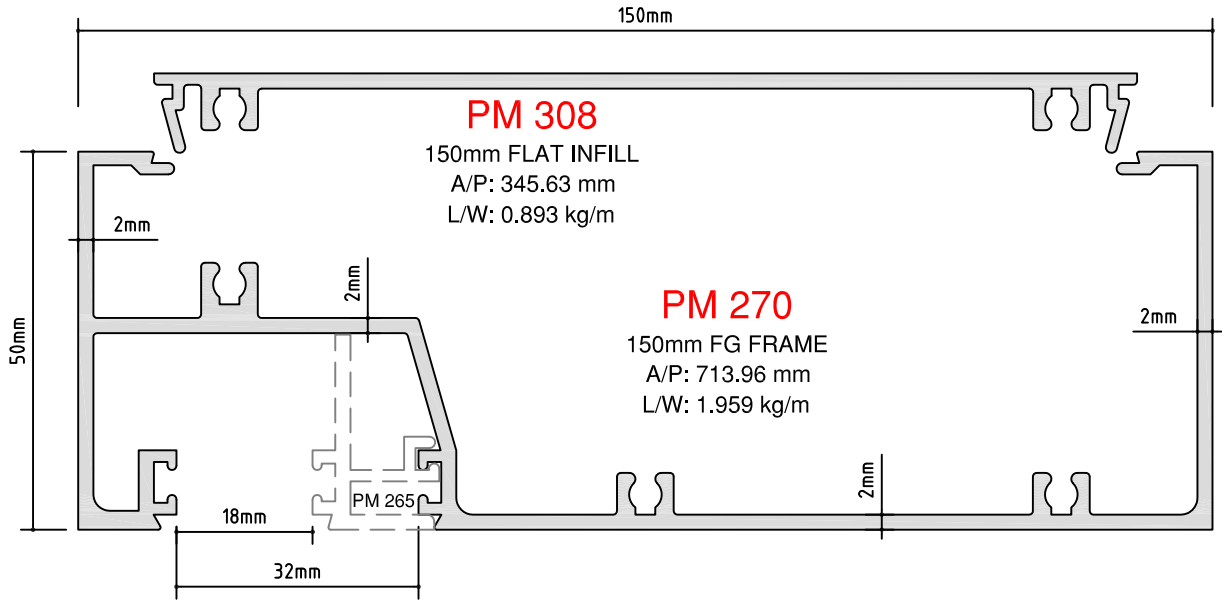

SCALE 1:1

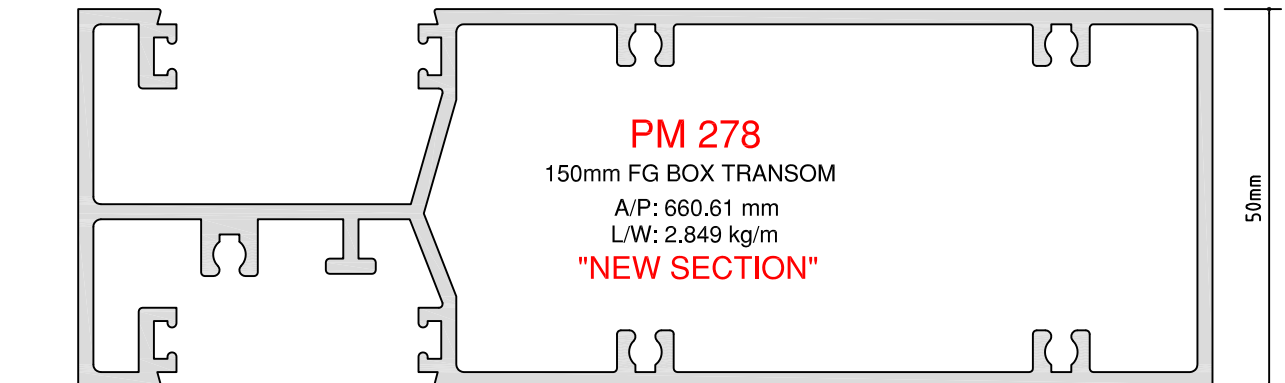
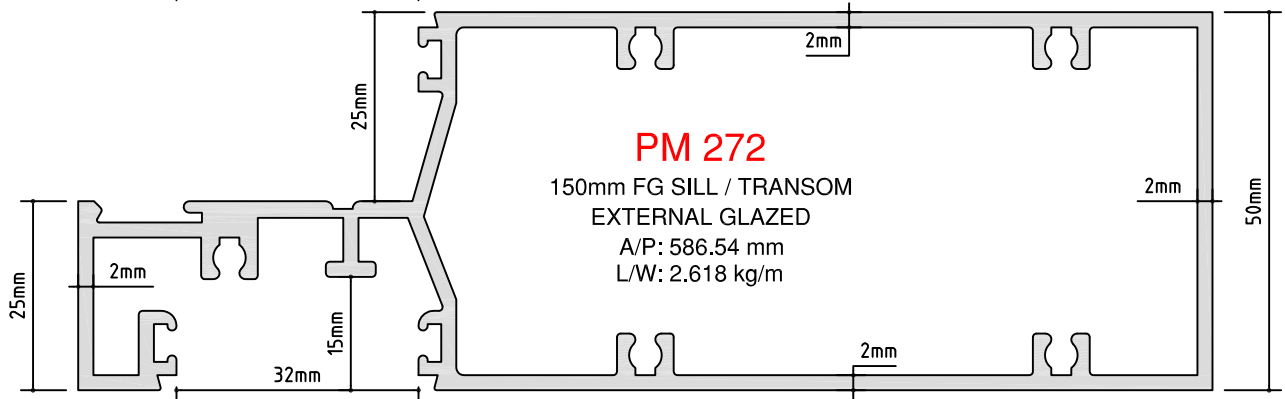



**8000 SERIES
150mm FRAME**

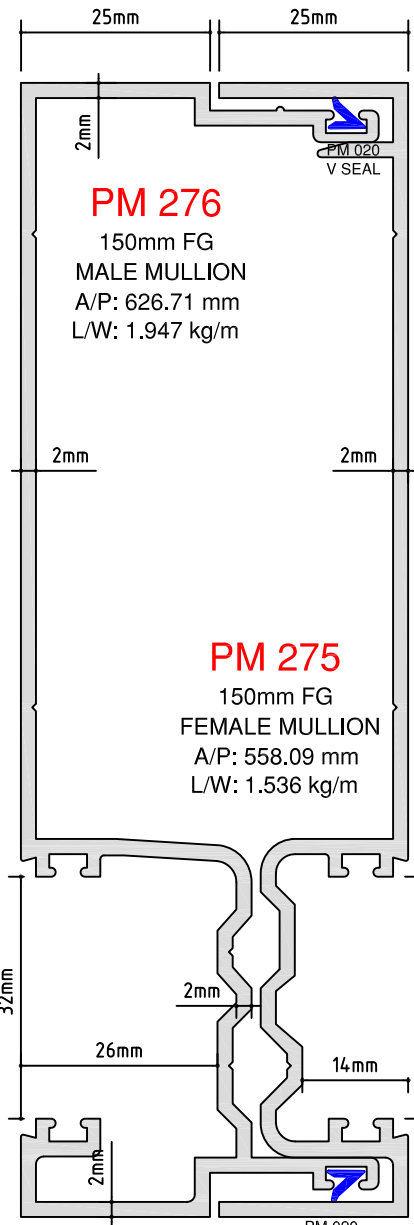

PM 276
150mm FG
MALE MULLION
A/P: 626.71 mm
L/W: 1.947 kg/m

PM 275
150mm FG
FEMALE MULLION
A/P: 558.09 mm
L/W: 1.536 kg/m

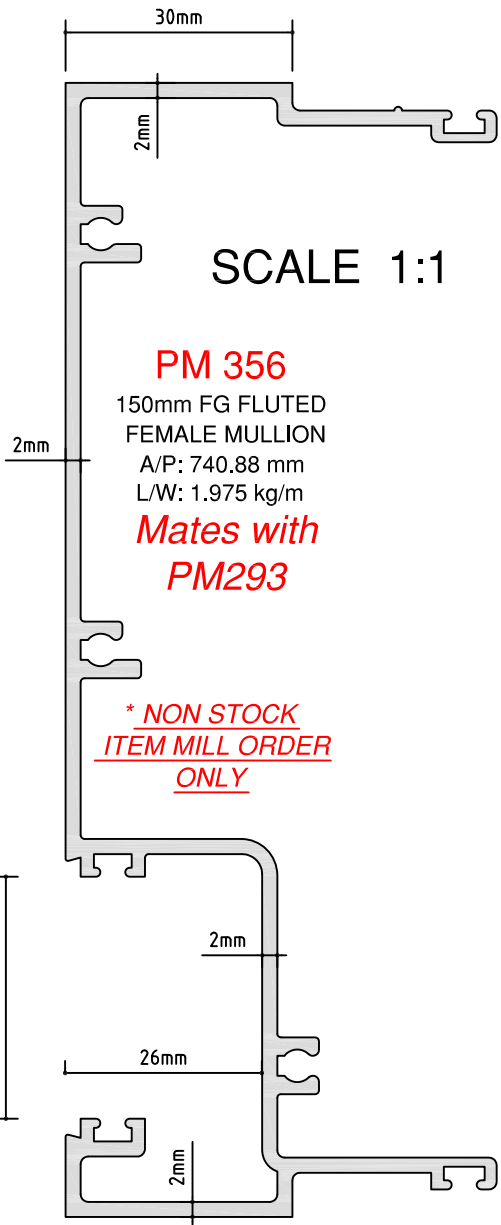

SCALE 1:1

PM 356
150mm FG FLUTED
FEMALE MULLION
A/P: 740.88 mm
L/W: 1.975 kg/m
*Mates with
PM293*

** NON STOCK
ITEM MILL ORDER
ONLY*

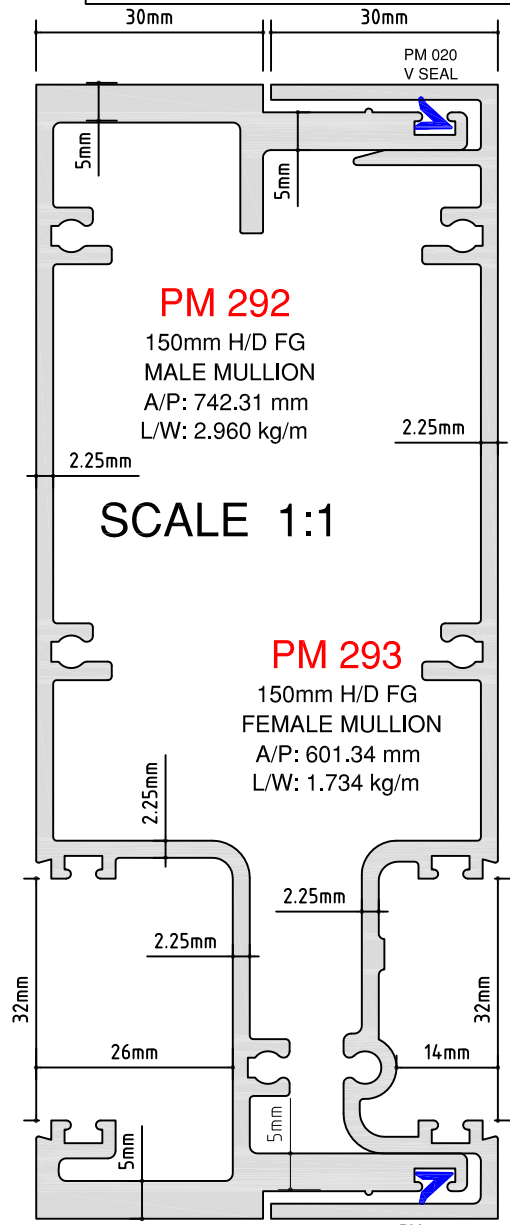

SCALE 1:1

PM 292
150mm H/D FG
MALE MULLION
A/P: 742.31 mm
L/W: 2.960 kg/m

PM 293
150mm H/D FG
FEMALE MULLION
A/P: 601.34 mm
L/W: 1.734 kg/m

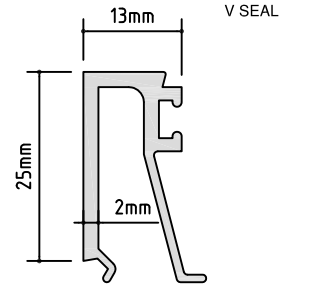

PM 291
FG EXTERNAL BEAD
(Fits Section PM251 & PM272)
A/P: 150.10 mm
L/W: 0.343 kg/m

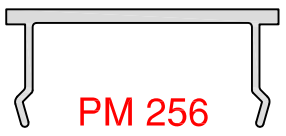

PM 256
DG POCKET FILLER
A/P: 128.68 mm
L/W: 0.251 kg/m

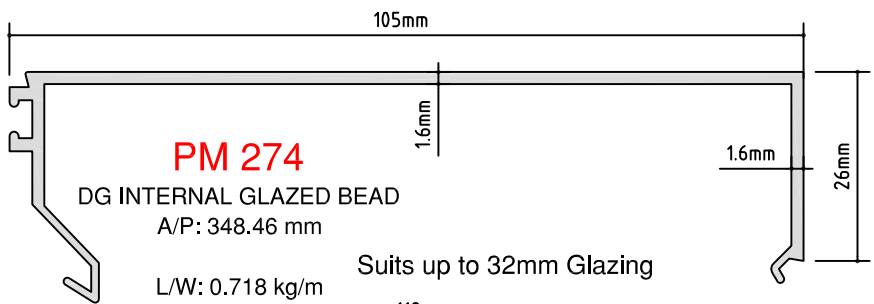

PM 274
DG INTERNAL GLAZED BEAD
A/P: 348.46 mm
L/W: 0.718 kg/m
Suits up to 32mm Glazing

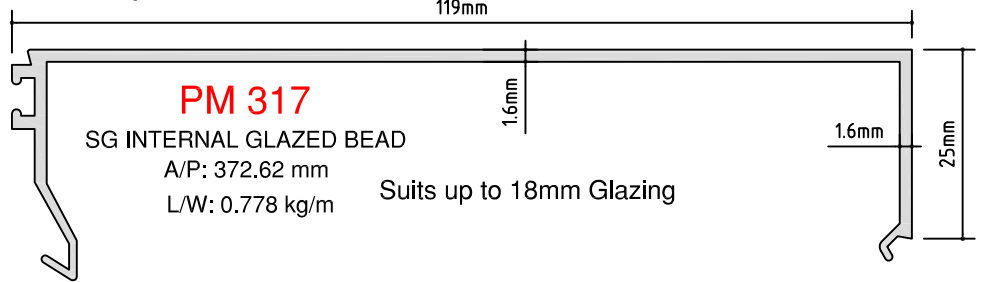

PM 317
SG INTERNAL GLAZED BEAD
A/P: 372.62 mm
L/W: 0.778 kg/m
Suits up to 18mm Glazing



**8000 SERIES
50mm AWNING SASH**

SCALE 1:1

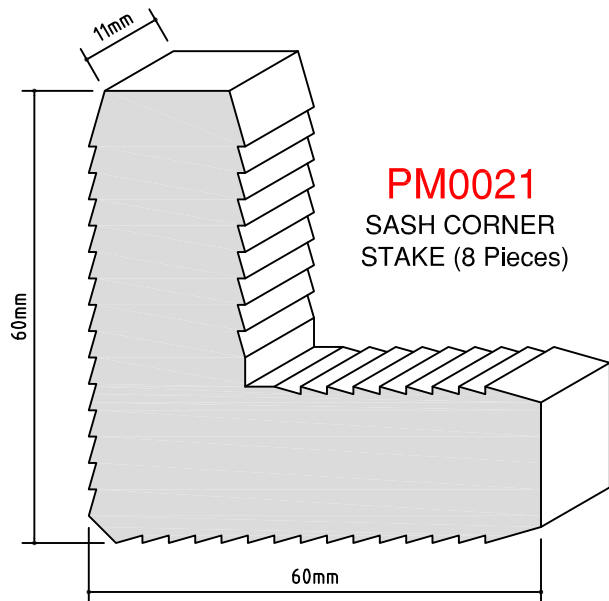
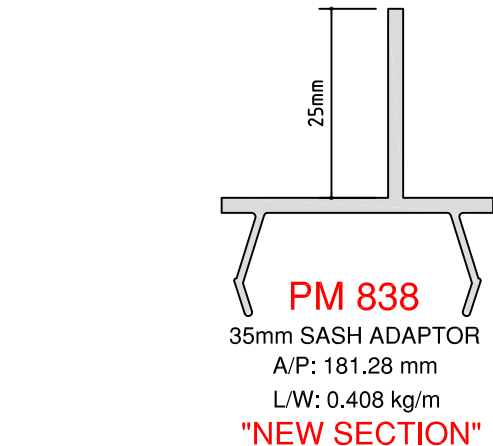
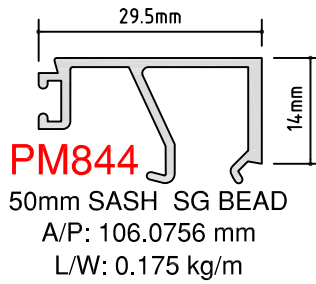
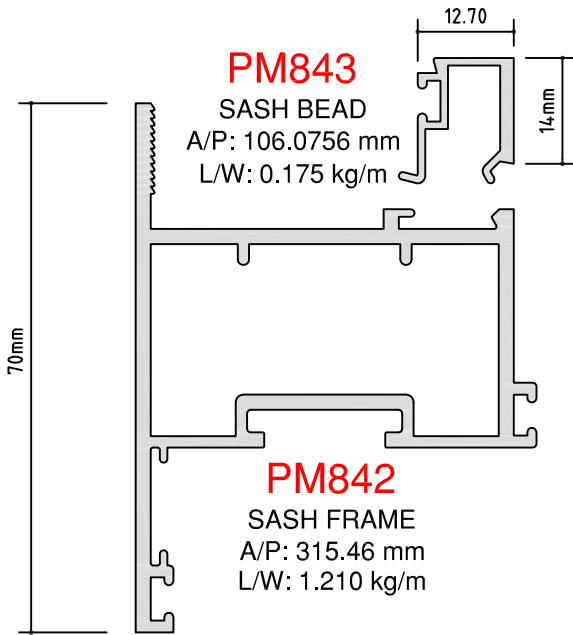
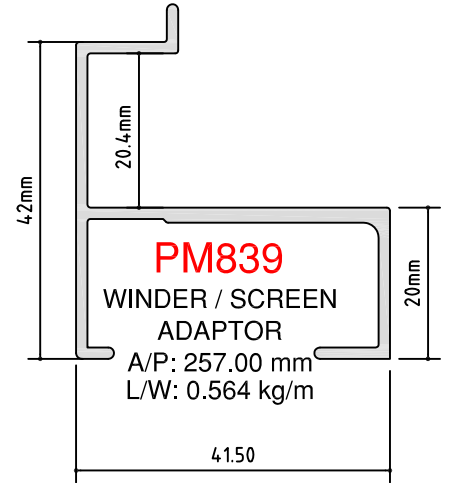
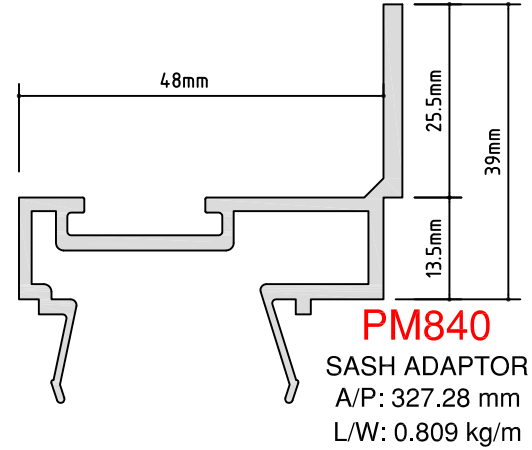
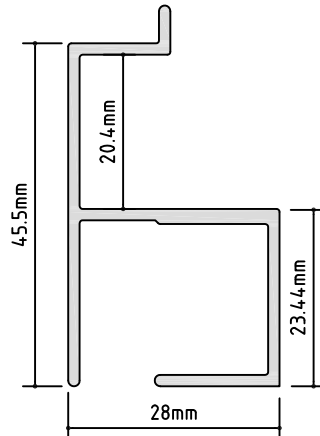
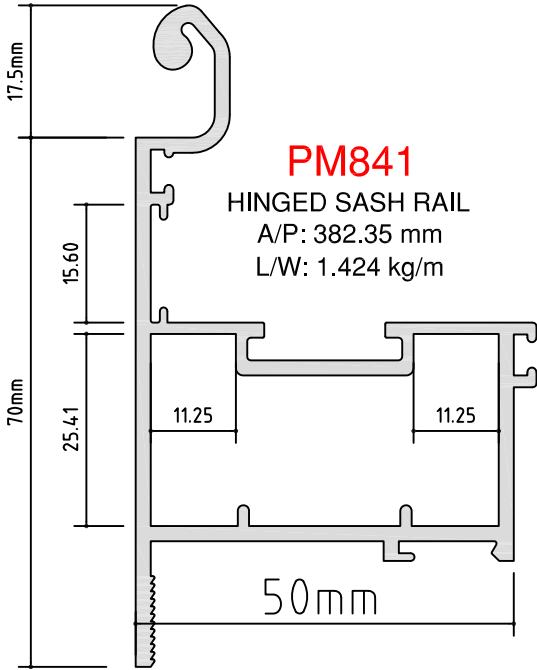



8000 SERIES
50mm AWNING SASH

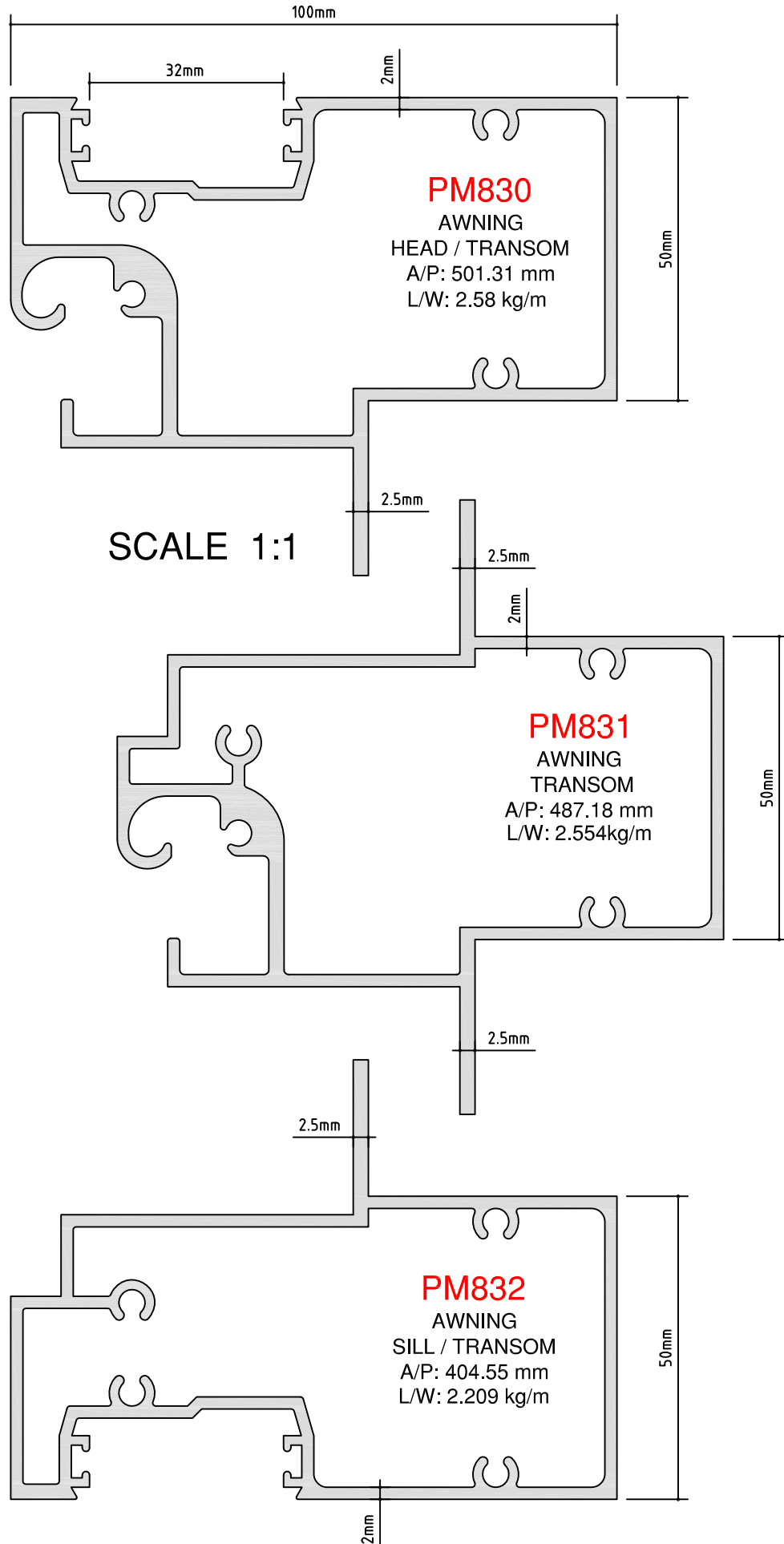



**8000 SERIES
50mm AWNING SASH**

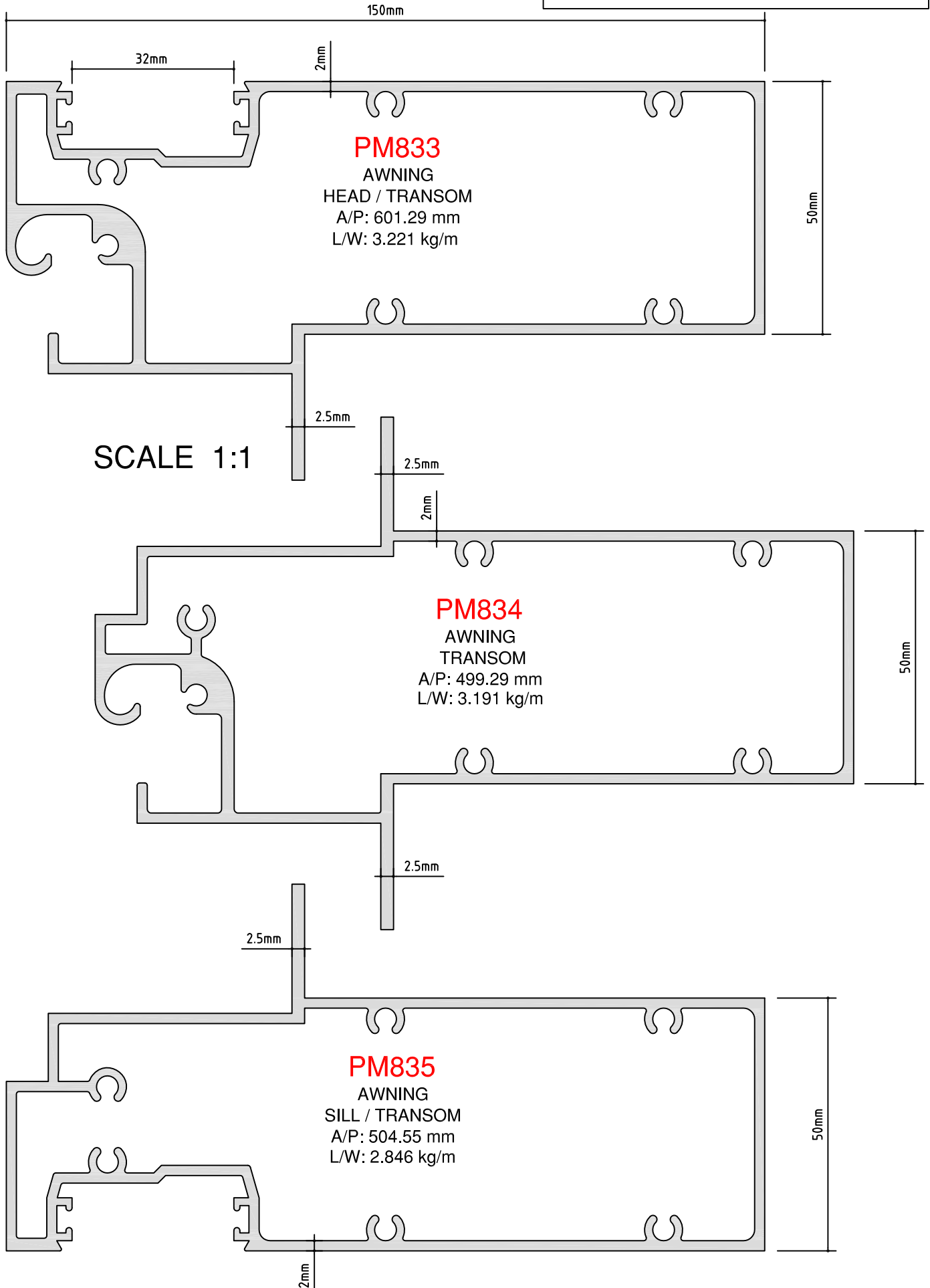



**8000 SERIES - 45mm DG or SG
COMMERCIAL DOORS**

SCALE 1:1

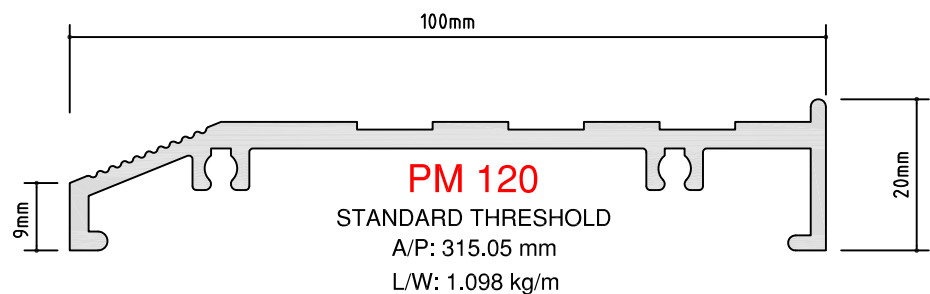
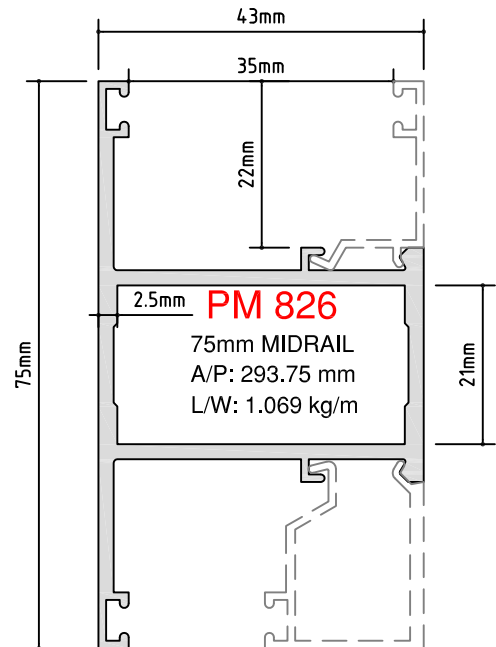
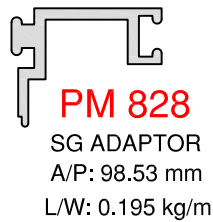
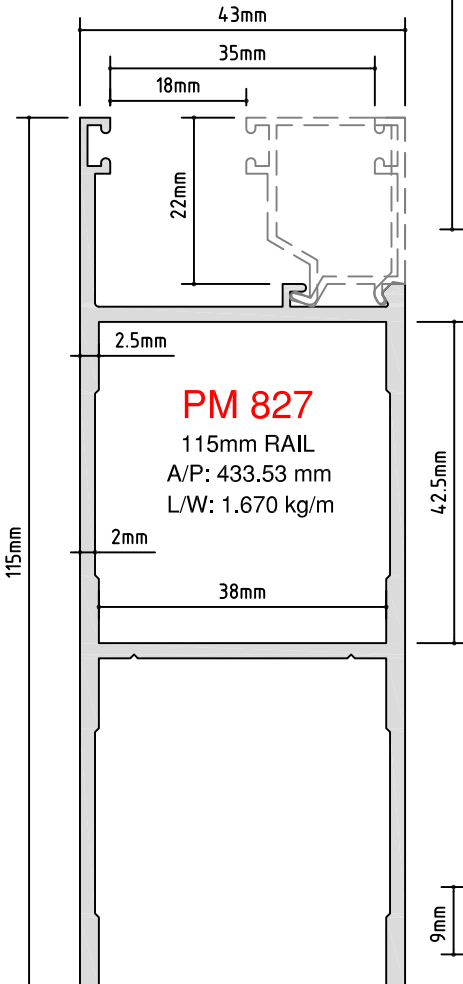
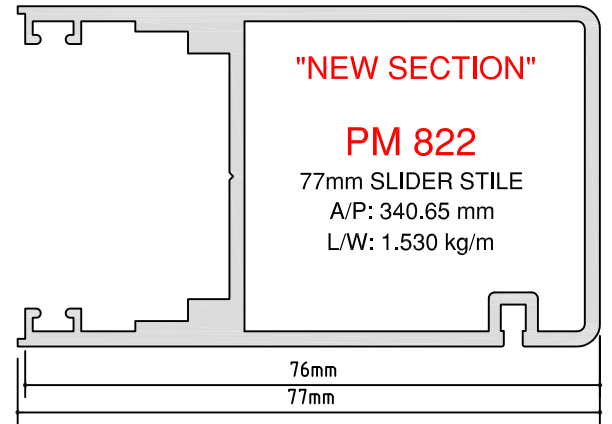
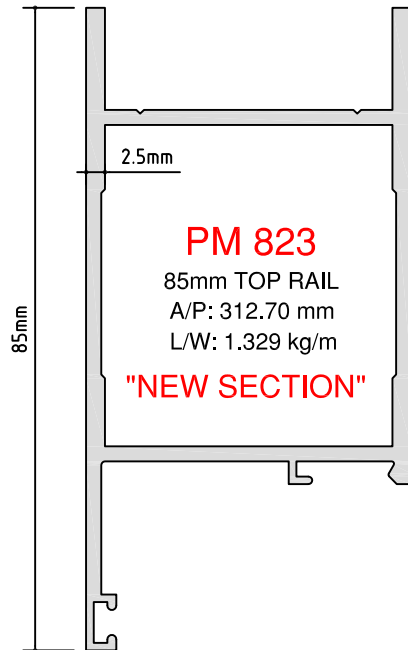
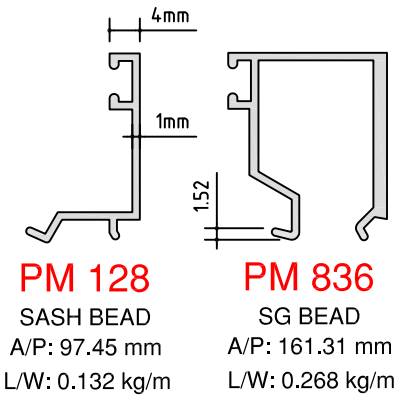
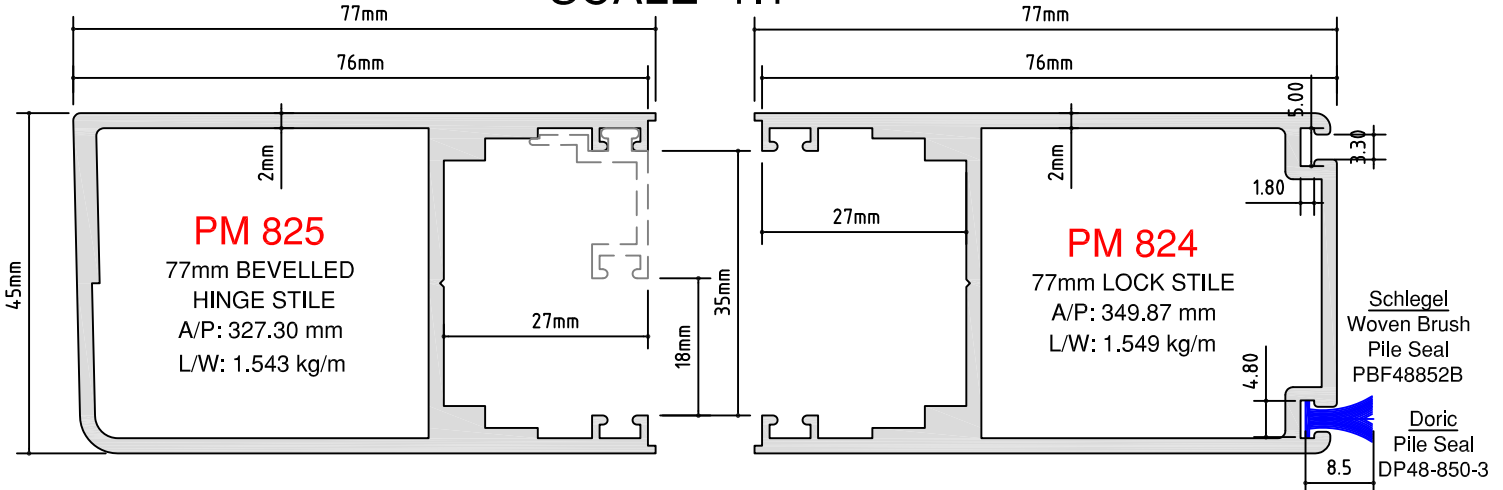



**8000 SERIES - 45mm DG or SG
COMMERCIAL DOORS**

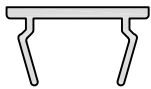

PM 721
UNIVERSAL DOOR
STOP BEAD
A/P: 77.61 mm
L/W: 0.124 kg/m

PM021
BULB
SEAL

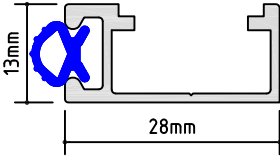

PM 722
UNIVERSAL DOOR
STOP BASE
A/P: 131.36 mm
L/W: 0.255 kg/m

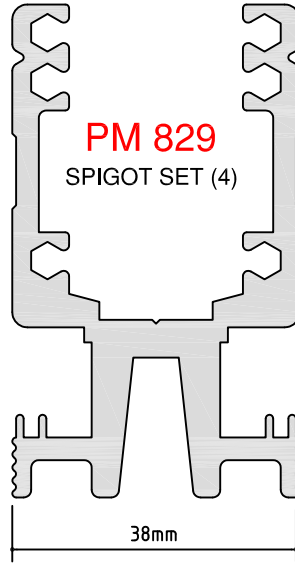

PM 829
SPIGOT SET (4)

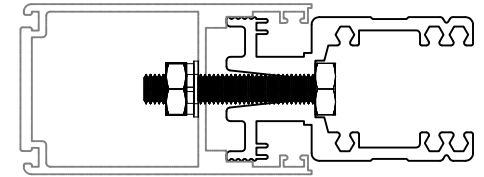
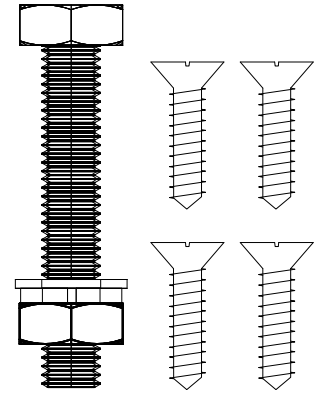

SCALE 1:1

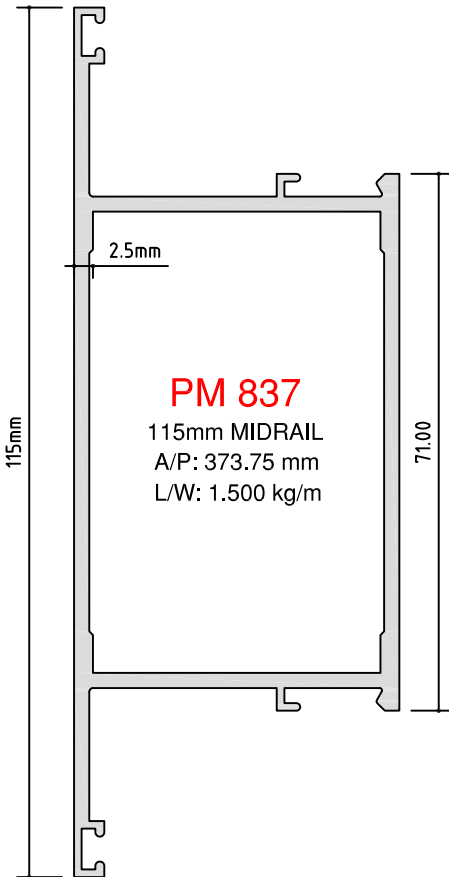

PM 837

115mm MIDRAIL
A/P: 373.75 mm
L/W: 1.500 kg/m

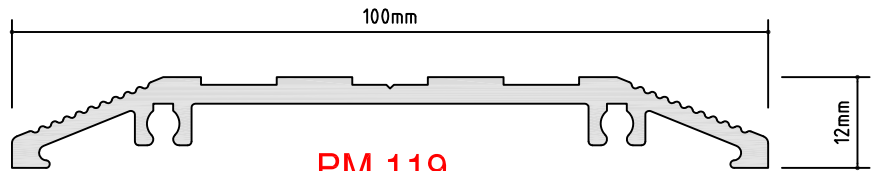

PM 119

SLOPED THRESHOLD
A/P: 276.18 mm
L/W: 0.925 kg/m

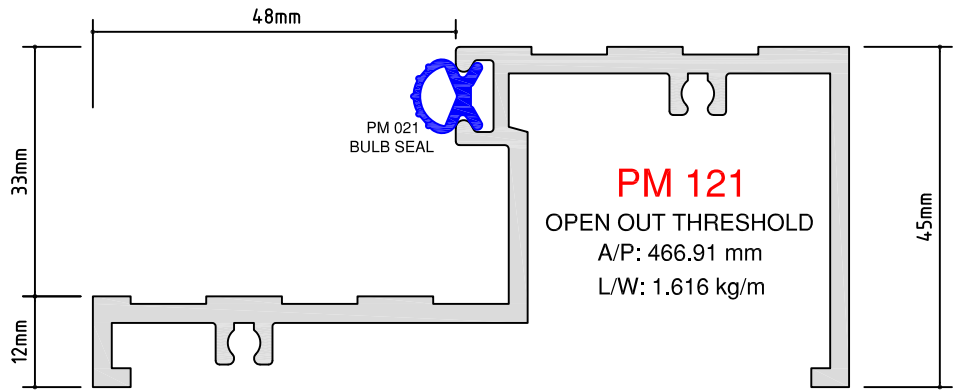

PM 121

OPEN OUT THRESHOLD
A/P: 466.91 mm
L/W: 1.616 kg/m

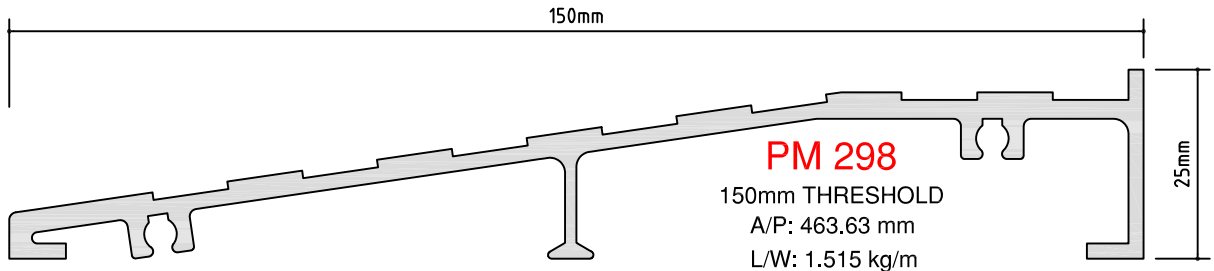

PM 298

150mm THRESHOLD
A/P: 463.63 mm
L/W: 1.515 kg/m

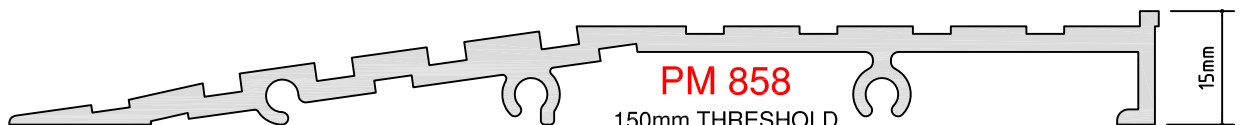

PM 858

150mm THRESHOLD
A/P: 440.30 mm
L/W: 1.570 kg/m



**8000 SERIES
SLIDING DOORS**

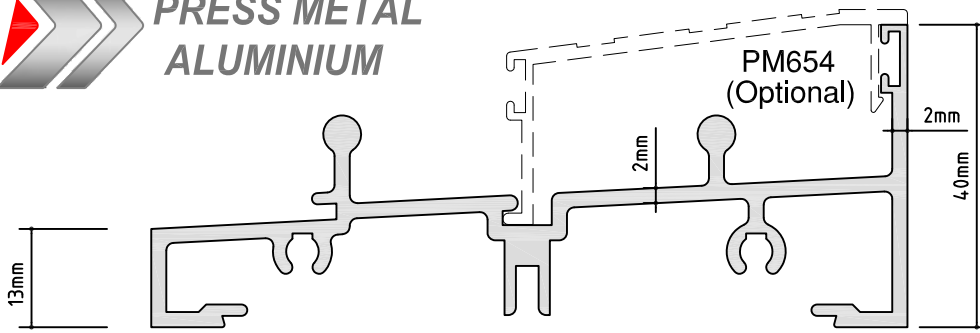

PM 674

100mm LOW PROFILE SILL
A/P: 512.58 mm
L/W: 1.421 kg/m

SCALE 1:1

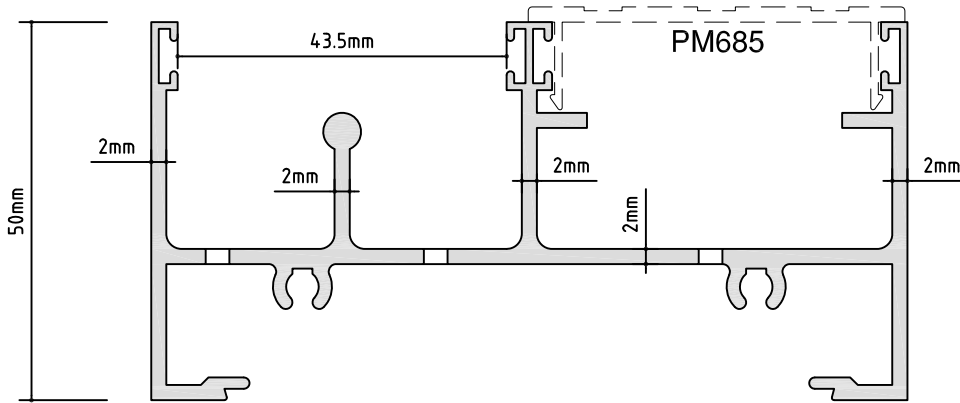

PM 666

100mm L/W STANDARD SILL
A/P: 663.56 mm
L/W: 1.713 kg/m

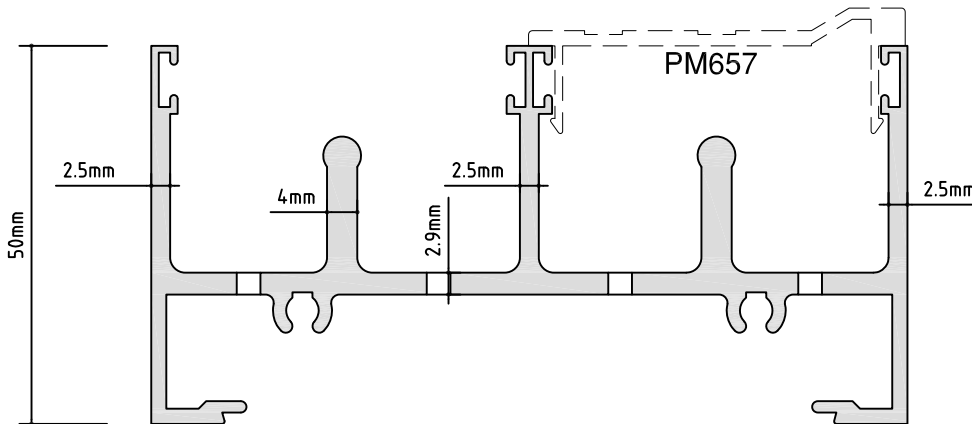

PM 671

100mm H/D STANDARD SILL
A/P: 652.85 mm
L/W: 2.186 kg/m

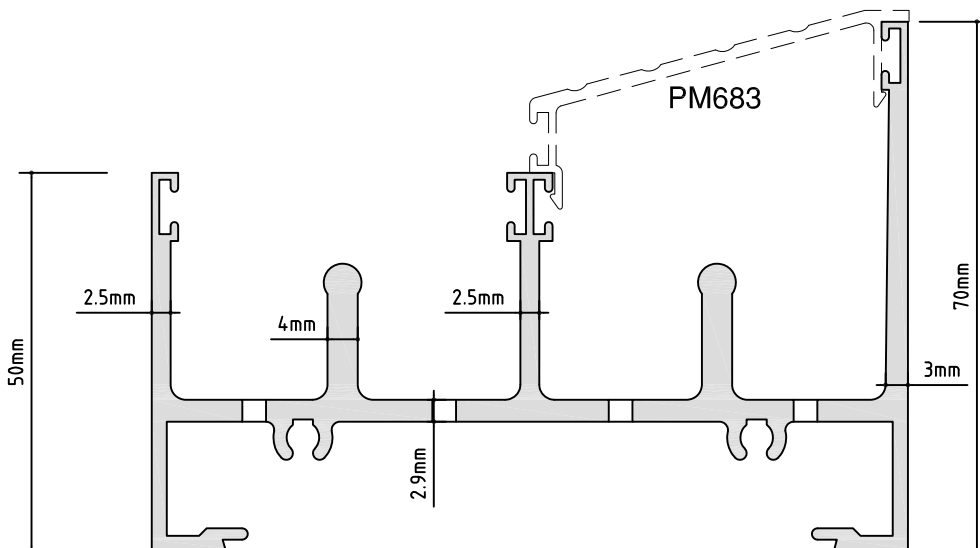

PM 673

100mm HIGH PERFORMANCE SILL
A/P: 689.98 mm
L/W: 2.343 kg/m

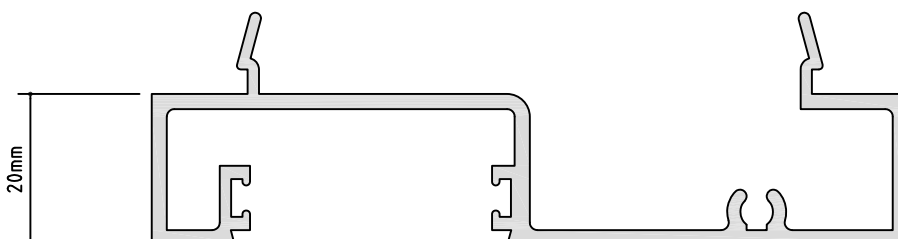

PM 257

100mm LOW LITE ADAPTOR
A/P: 458.94 mm
L/W: 1.202 kg/m



WHEELCHAIR THRESHOLD

A/P: 178.32
L/W: 0.340 kg/m

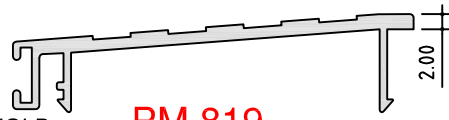

PM 819

100mm WHEELCHAIR SILL

A/P: 300.61
L/W: 0.792 kg/m

8000 SERIES
SLIDING DOORS

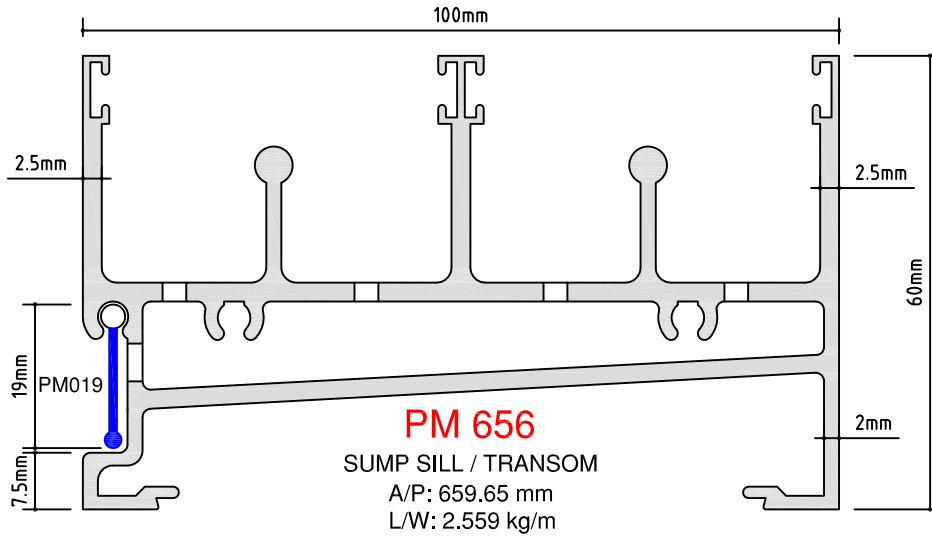

SCALE 1:1

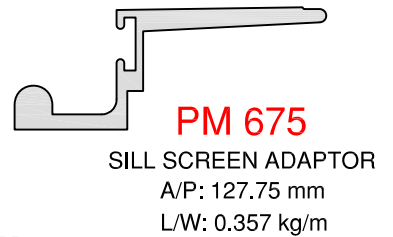
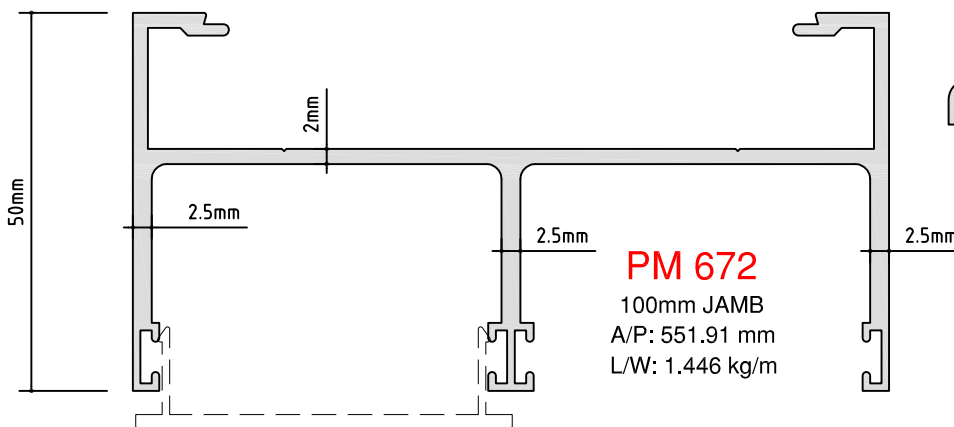
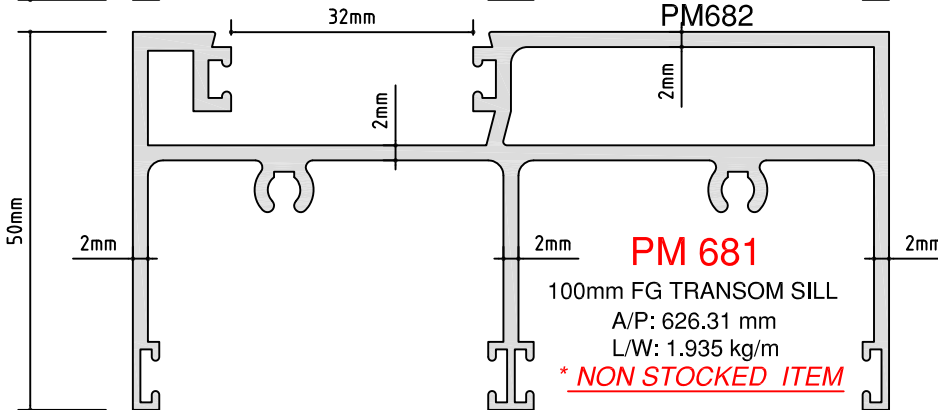
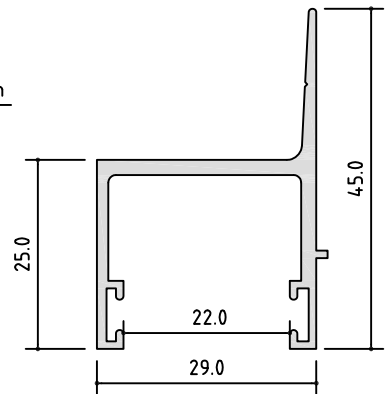
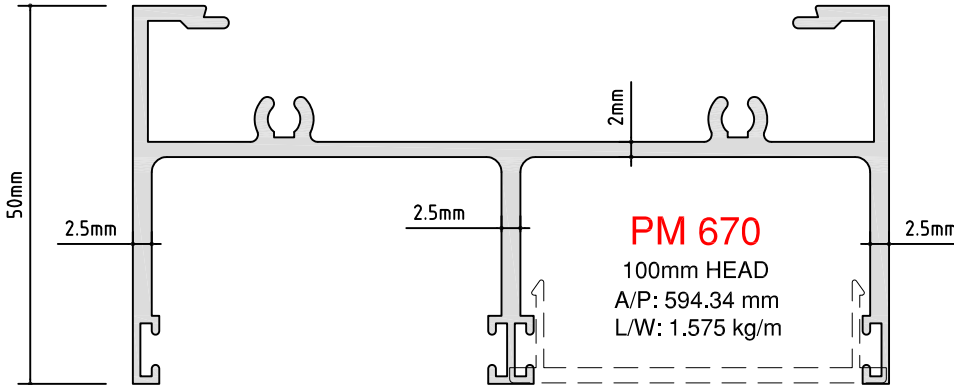

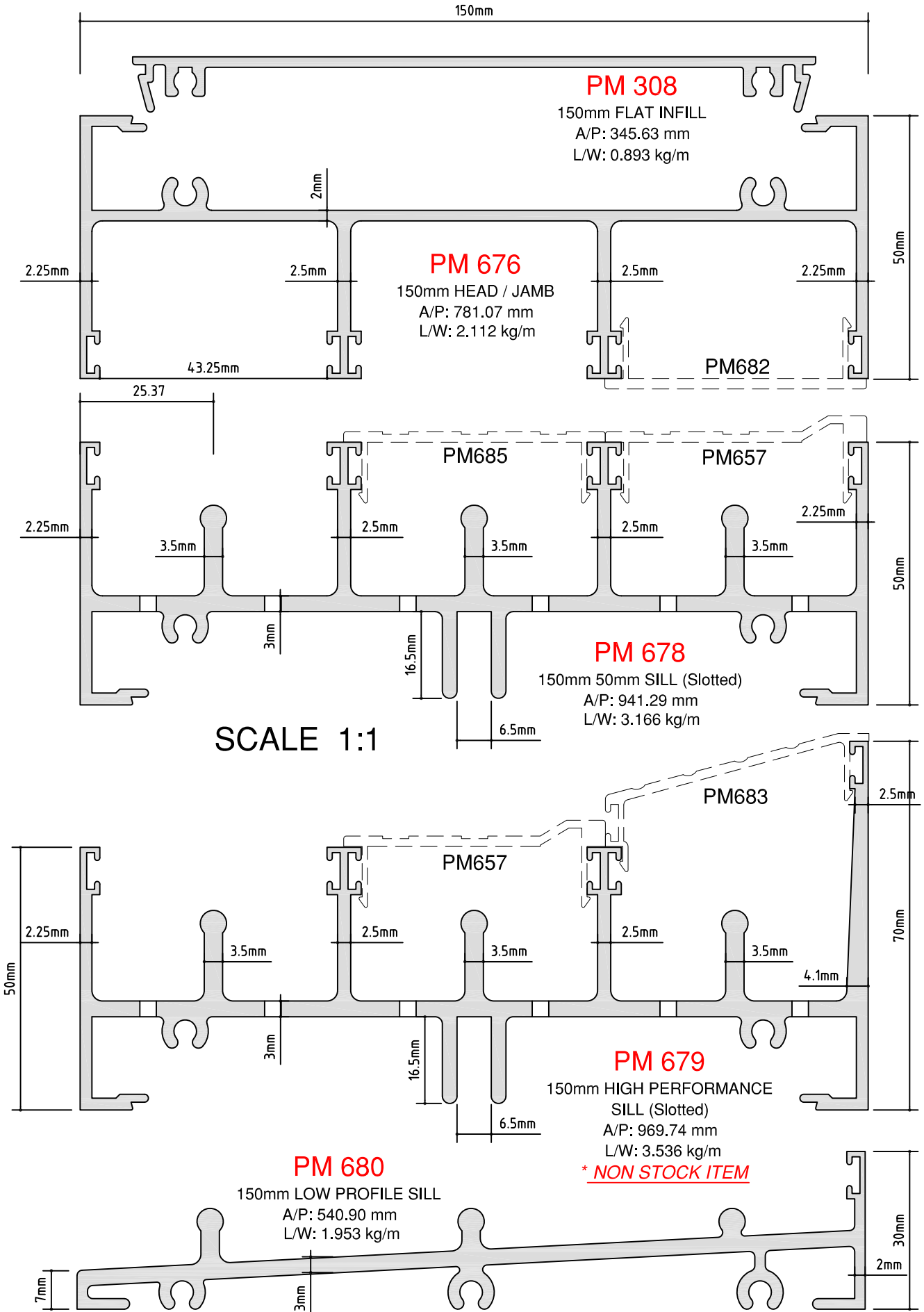

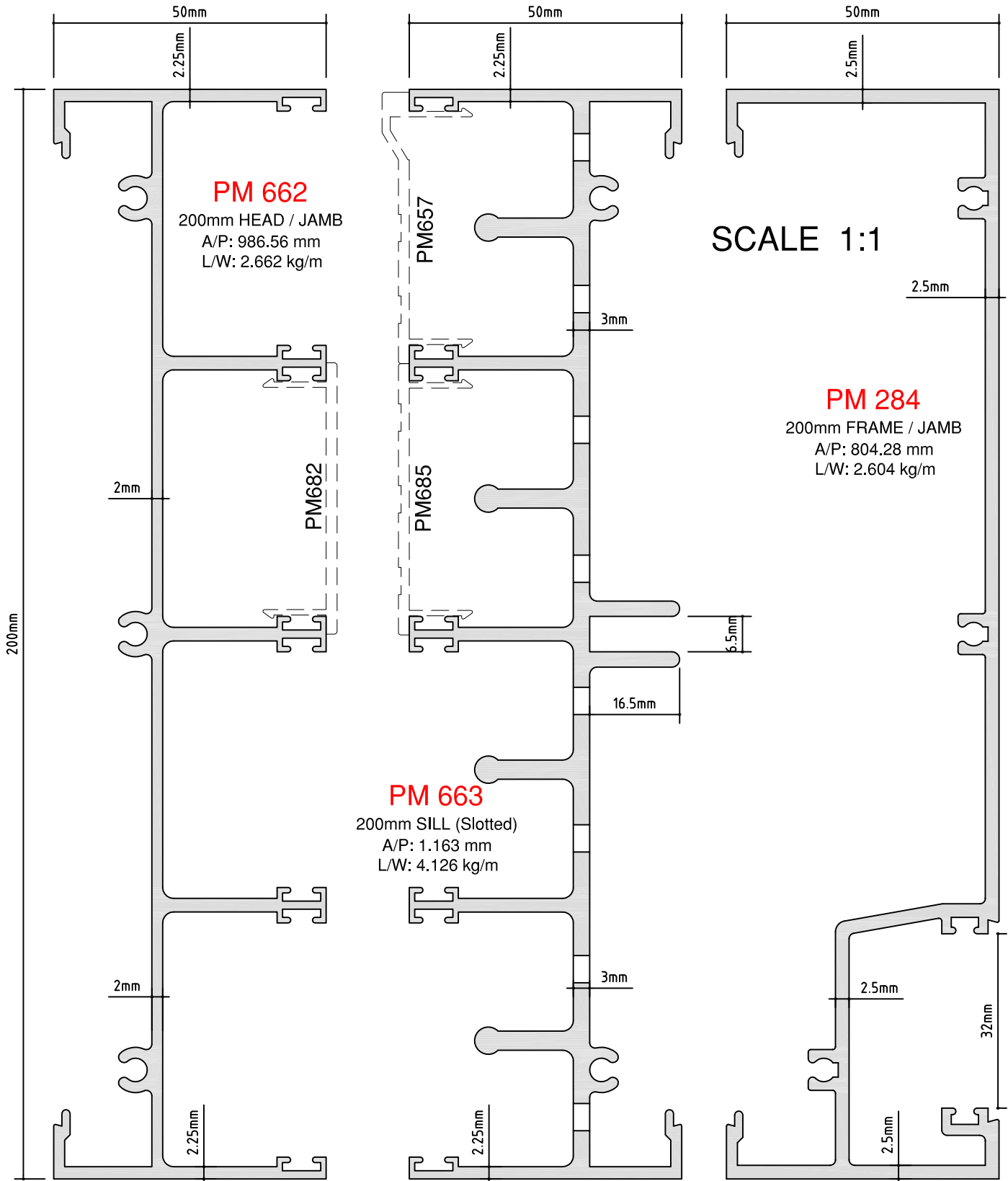

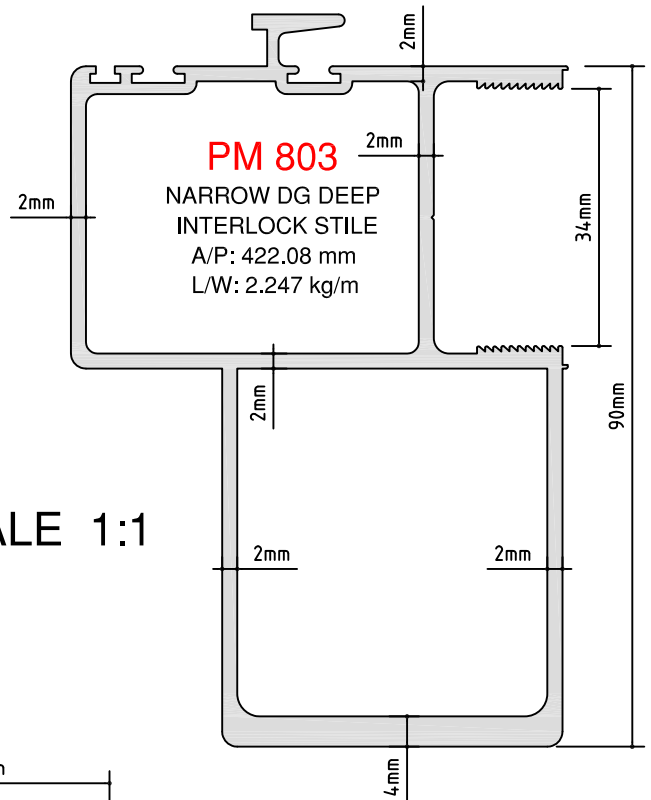
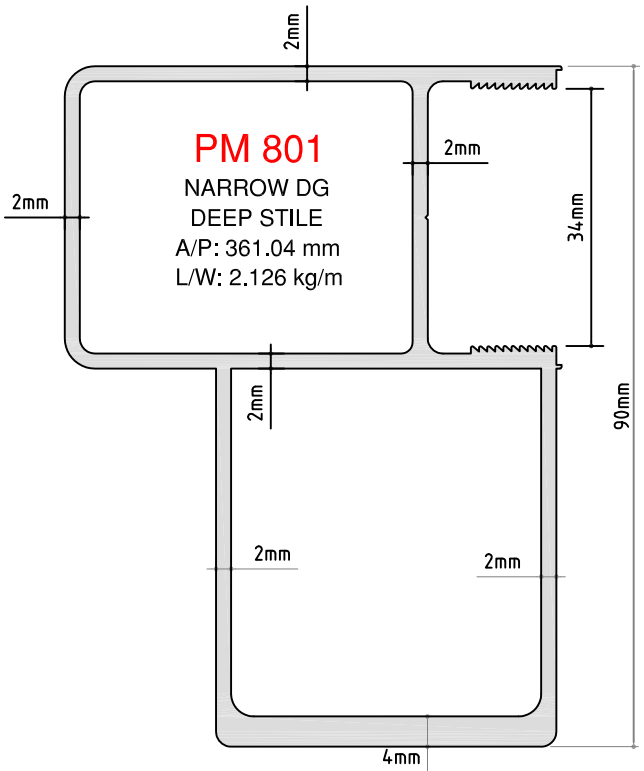
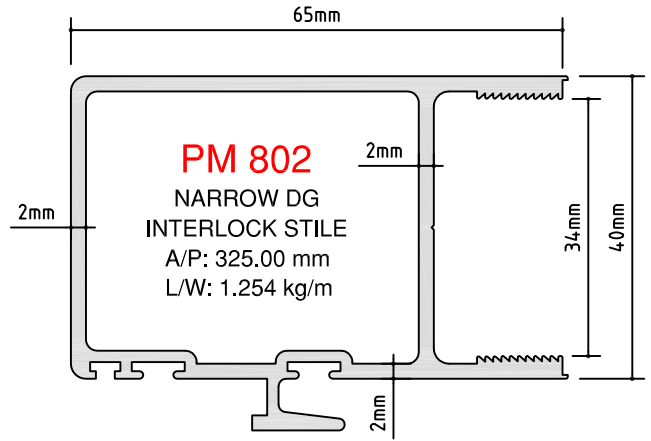
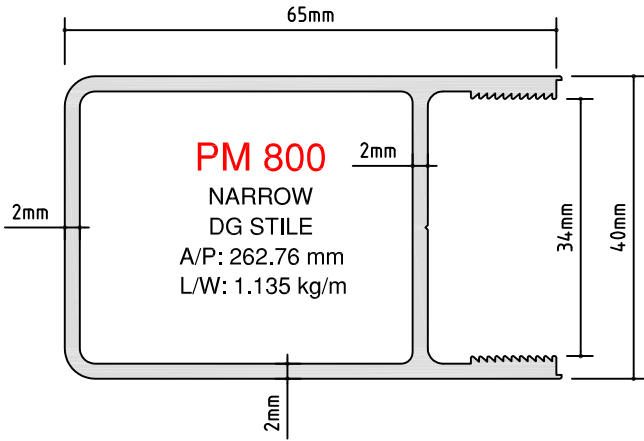

SCALE 1:1

PM 807
DG ONE PART RAIL
A/P: 424.97 mm
L/W: 1.355 kg/m

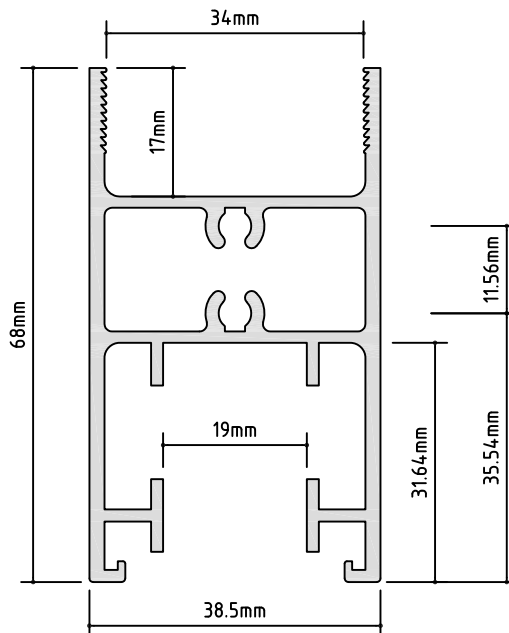

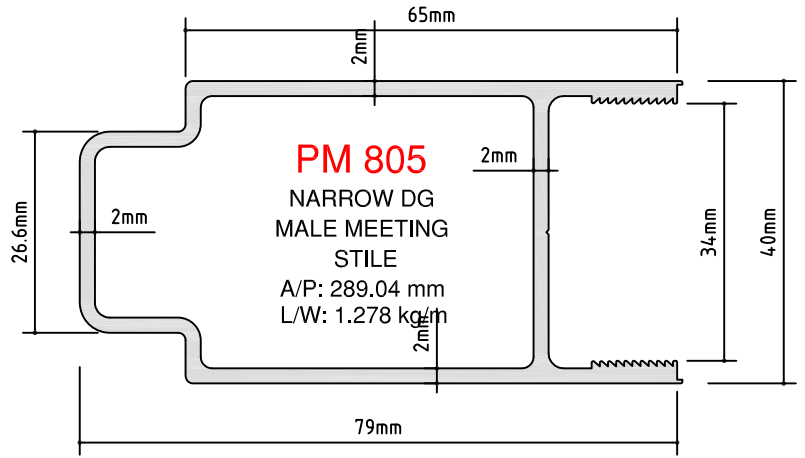
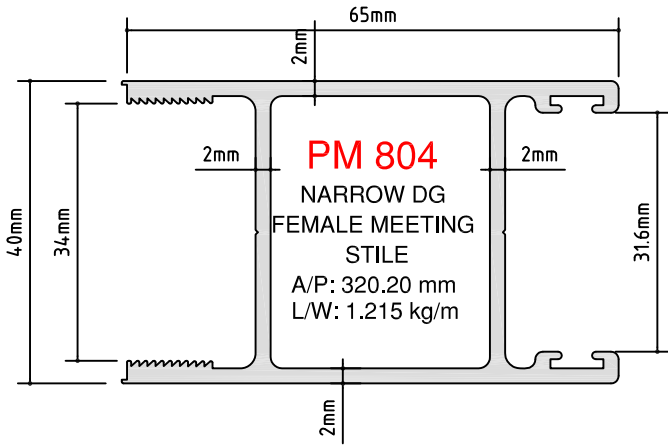

SCALE 1:1

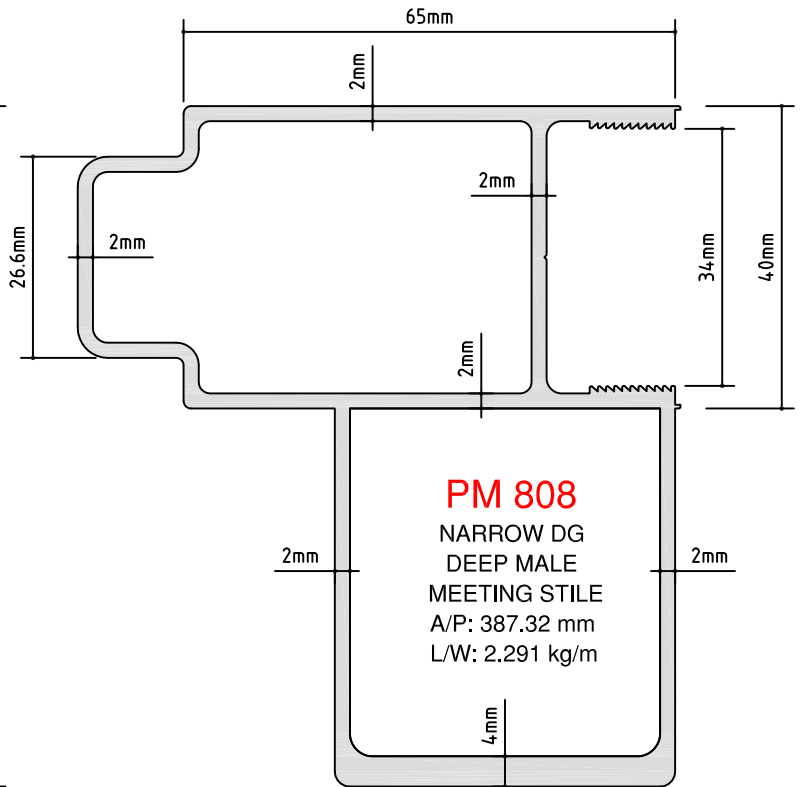
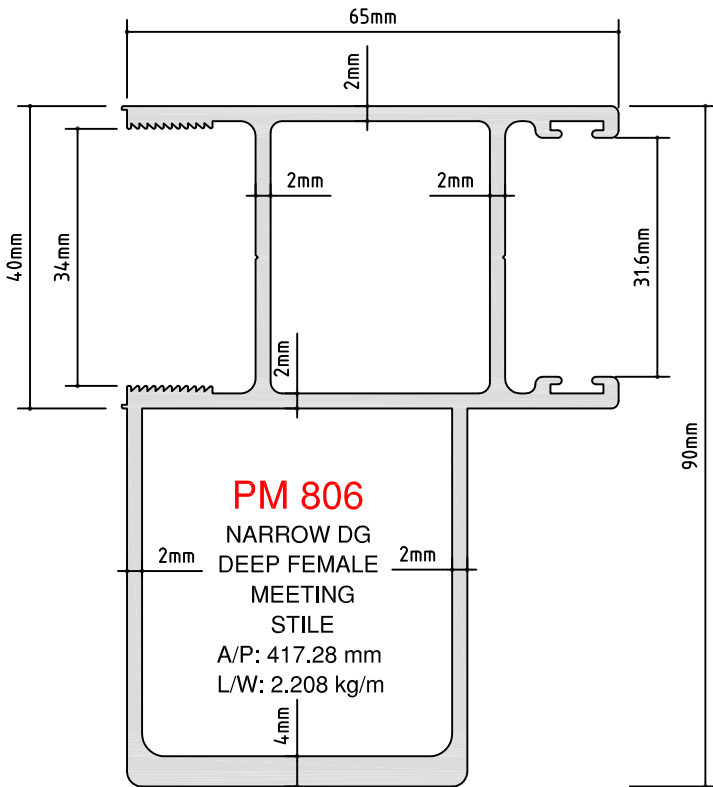

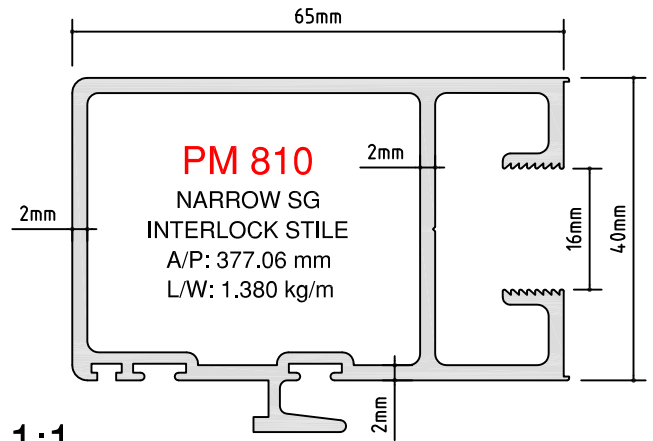
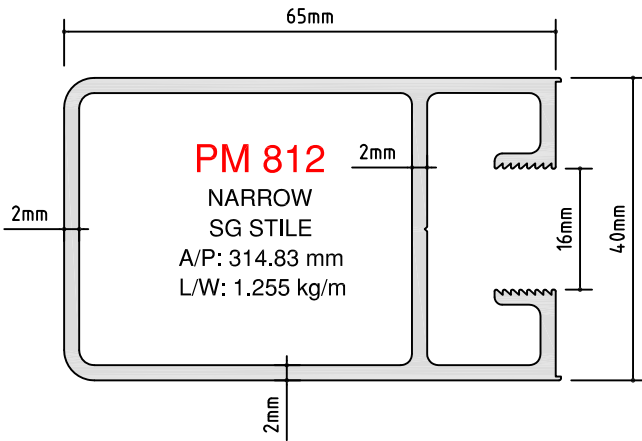

SCALE 1:1

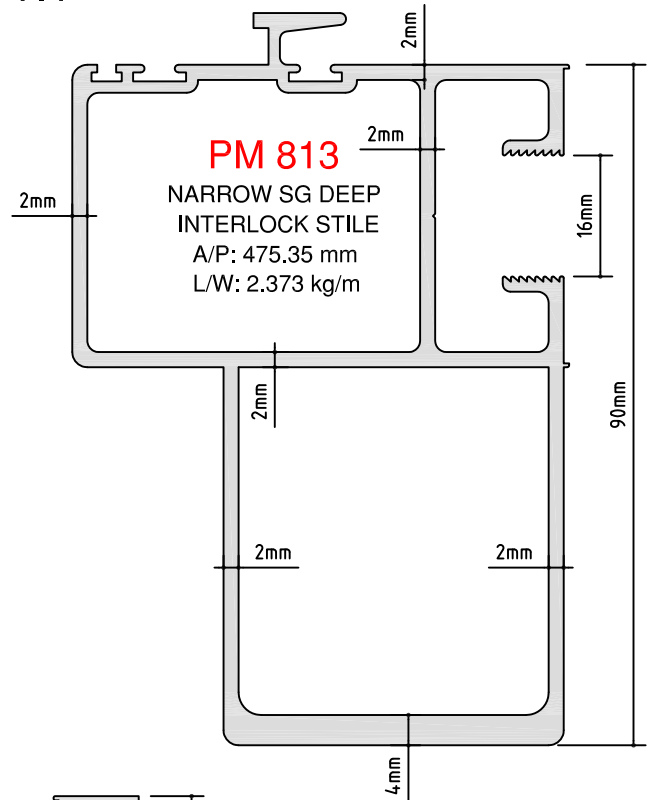
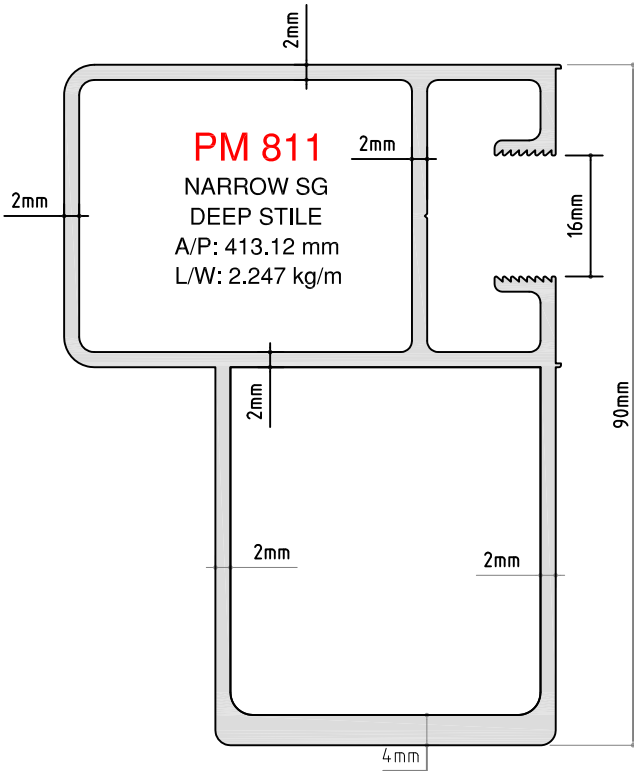

PM 817
ONE PART SG RAIL
A/P: 477.72 mm
L/W: 1.514 kg/m

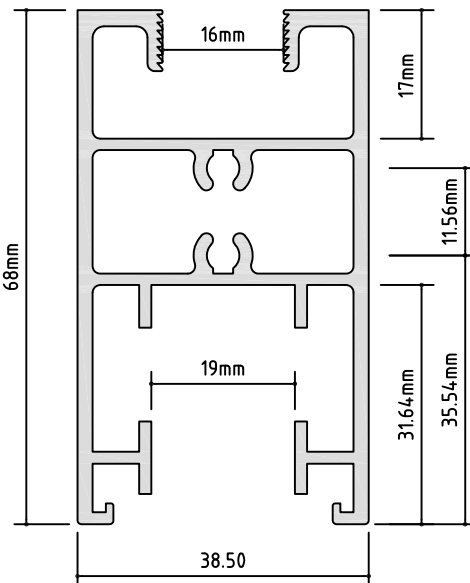

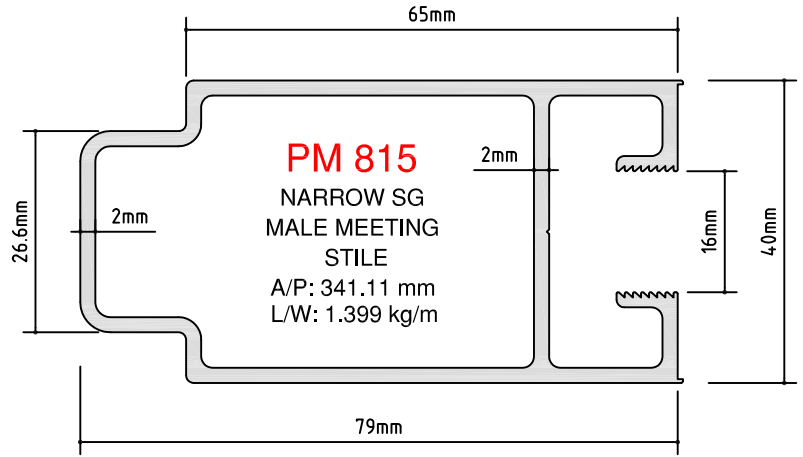
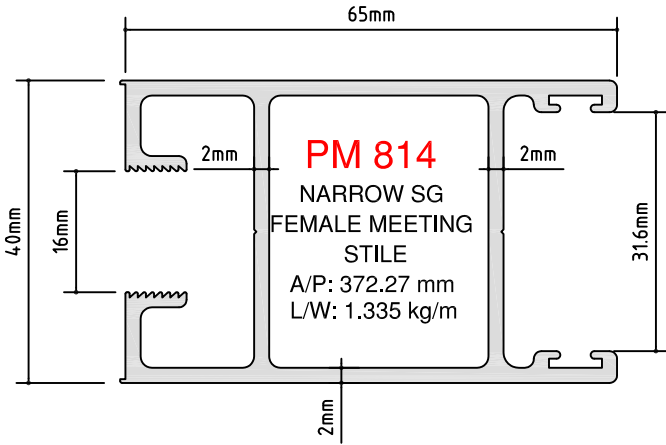

SCALE 1:1

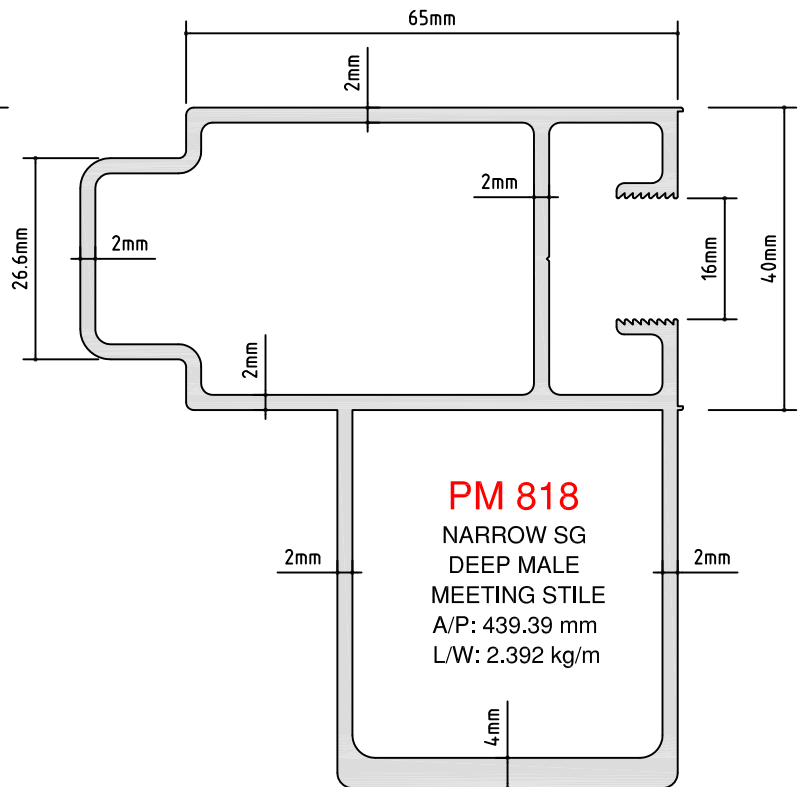
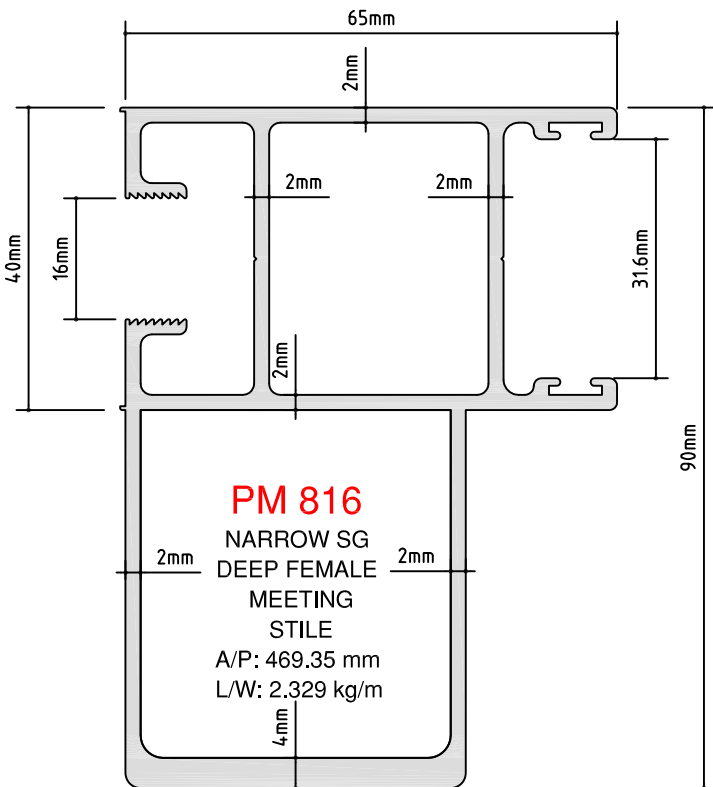

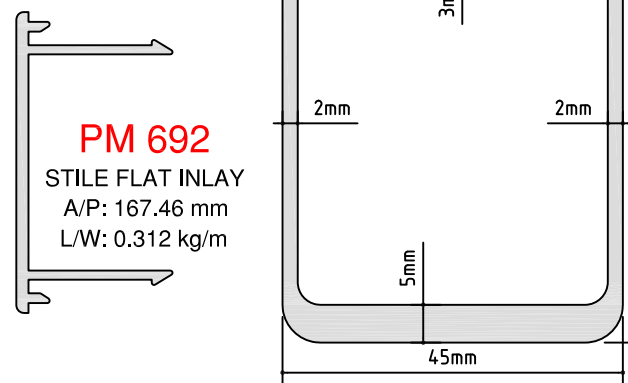
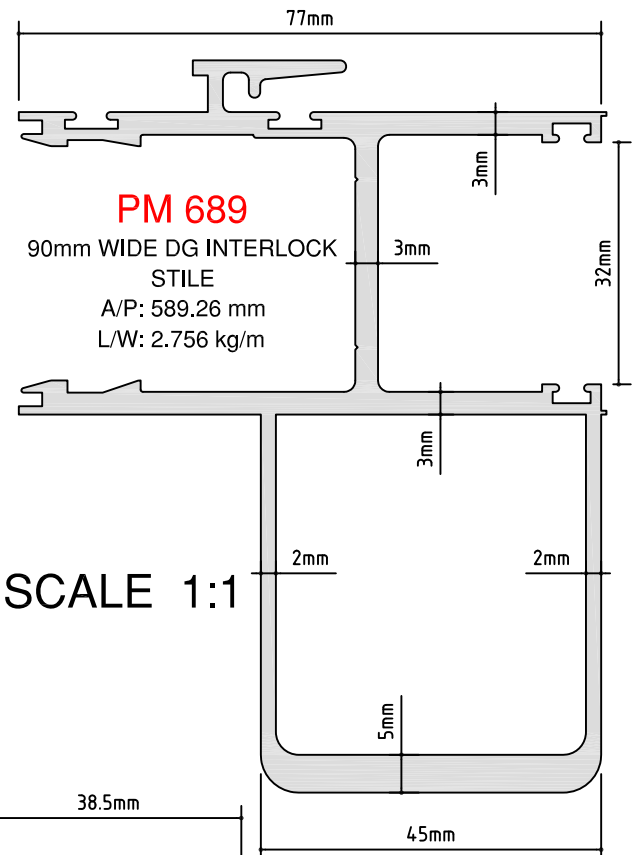
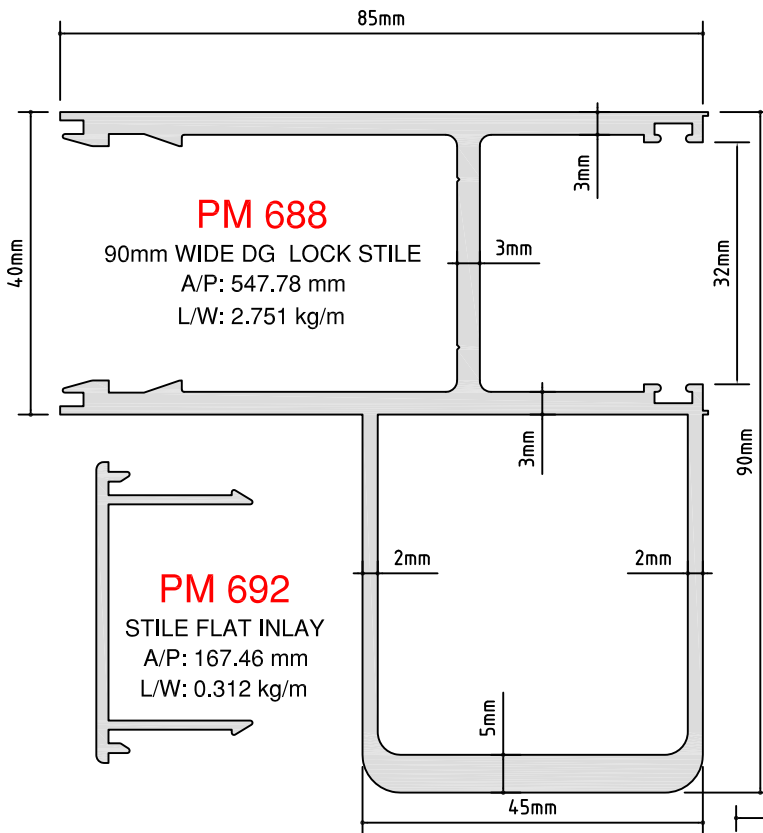
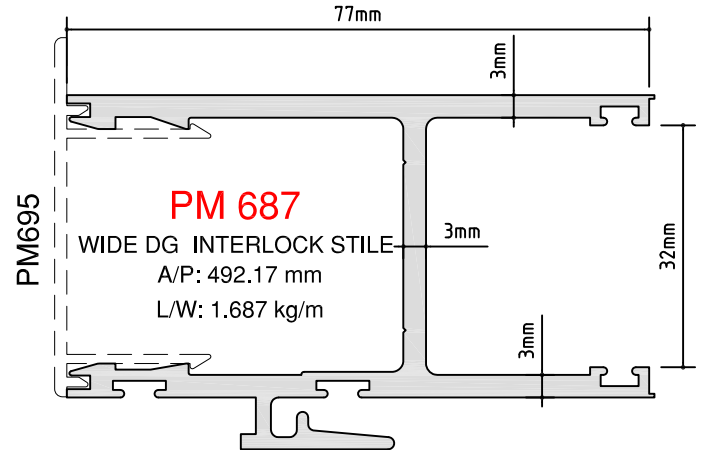
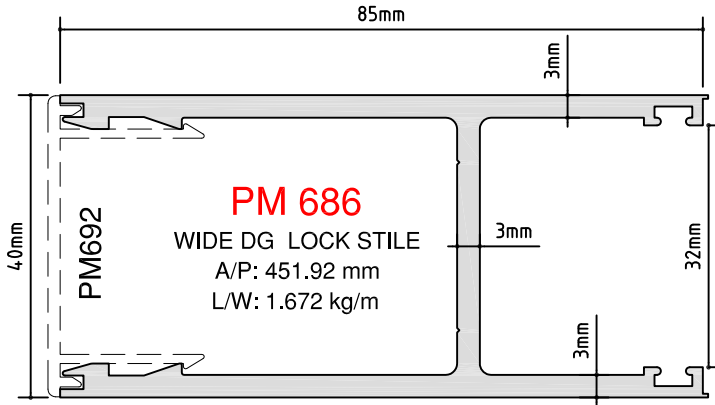

SCALE 1:1

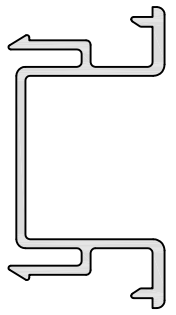

PM 694
FEMALE MEETING
STILE ADAPTOR
A/P: 198.04 mm
L/W: 0.328 kg/m

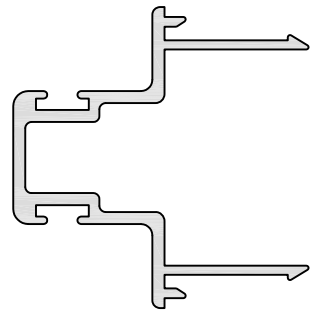

PM 693
MALE MEETING
STILE ADAPTOR
A/P: 253.74 mm
L/W: 0.519 kg/m

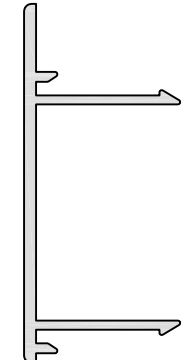
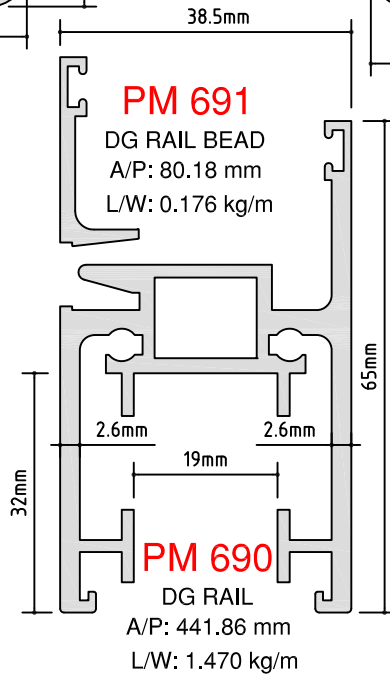

PM 695
INTERLOCK STILE INLAY
A/P: 182.86 mm
L/W: 0.345 kg/m

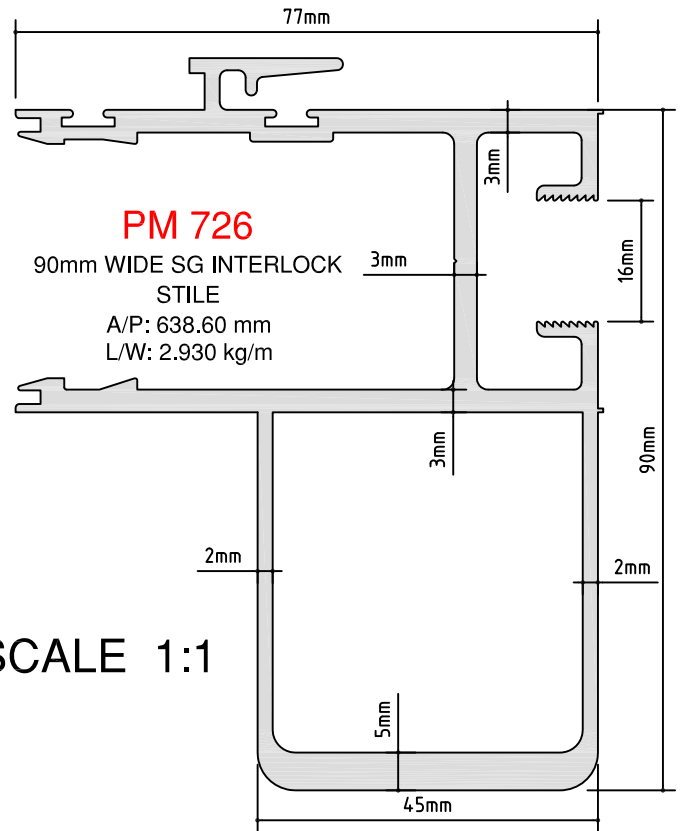
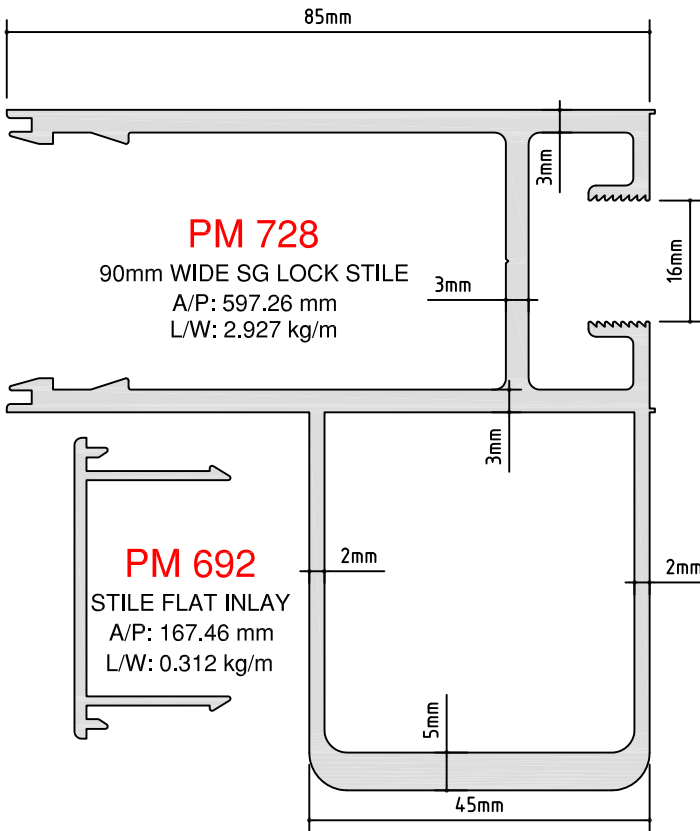
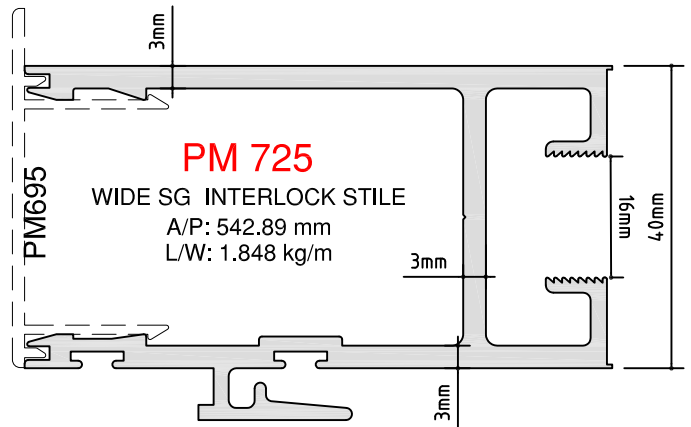
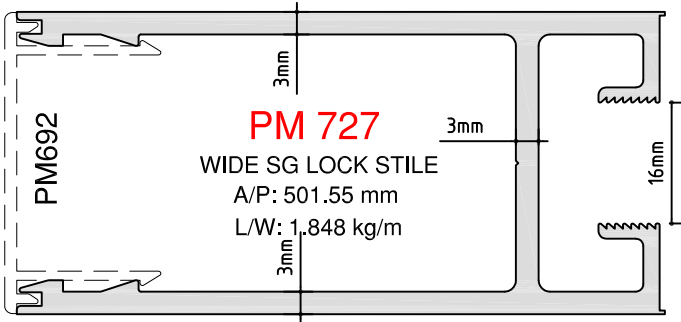

SCALE 1:1

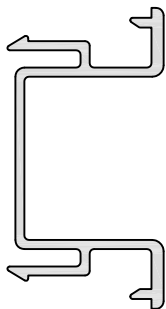

PM 694
FEMALE MEETING
STILE ADAPTOR
A/P: 198.04 mm
L/W: 0.328 kg/m

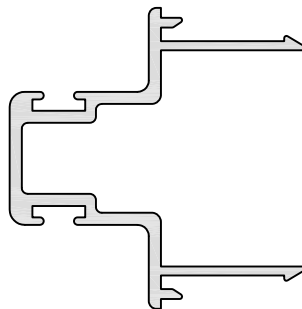

PM 693
MALE MEETING
STILE ADAPTOR
A/P: 253.74 mm
L/W: 0.519 kg/m

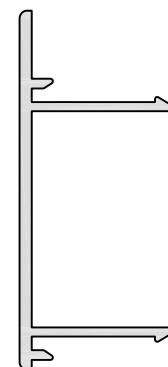

PM 695
INTERLOCK STILE INLAY
A/P: 182.86 mm
L/W: 0.345 kg/m



**8000 SERIES
SLIDING DOORS**

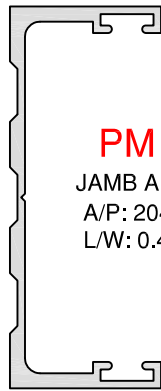

PM 655

JAMB ADAPTOR
A/P: 204.47 mm
L/W: 0.409 kg/m

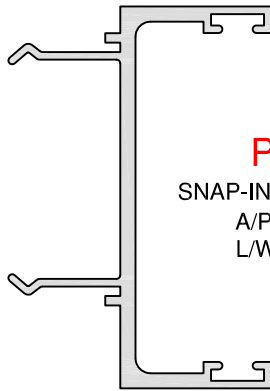

PM 658

SNAP-IN JAMB ADAPTOR
A/P: 271.15 mm
L/W: 0.329 kg/m

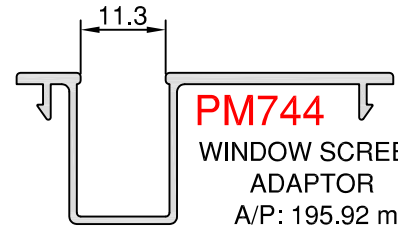

PM744

WINDOW SCREEN
ADAPTOR
A/P: 195.92 mm
L/W: 0.317 kg/m

PM 075
STILE CAP

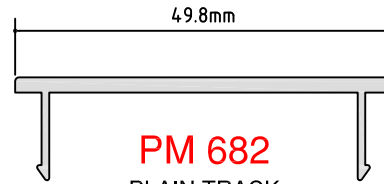
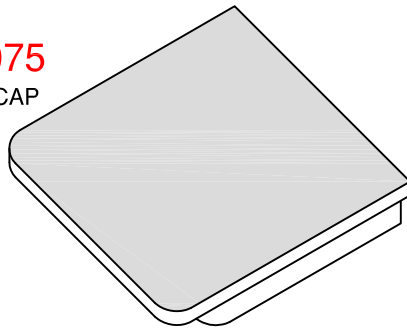

PM 682

PLAIN TRACK
JAMB INFILL
A/P: 149.84 mm
L/W: 0.334 kg/m

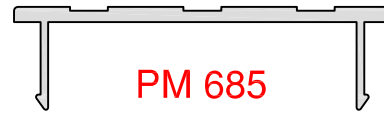

PM 685

FLAT THRESHOLD
A/P: 154.76 mm
L/W: 0.319 kg/m

PM067
INTERLOCK BLOCK

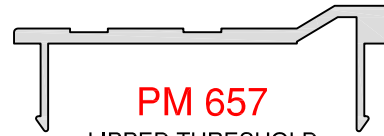
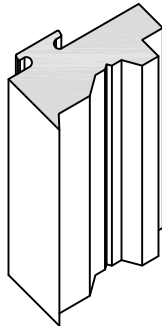

PM 657

LIPPED THRESHOLD
A/P: 160.33 mm
L/W: 0.350 kg/m

PM740
SCREEN DOOR
CHANNEL
A/P: 160.34 mm
L/W: 0.339 kg/m

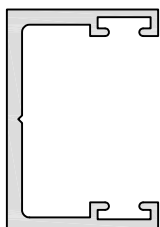

SCALE 1:1

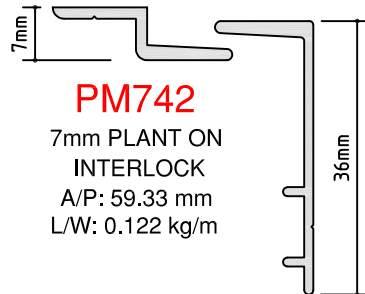

PM742

7mm PLANT ON
INTERLOCK
A/P: 59.33 mm
L/W: 0.122 kg/m

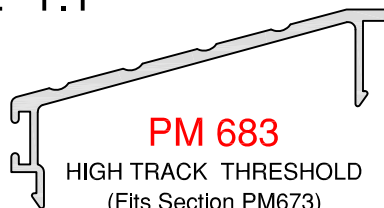

PM 683

HIGH TRACK THRESHOLD
(Fits Section PM673)
A/P: 170.22 mm
L/W: 0.332 kg/m

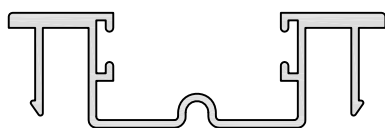

PM741

SCREEN DOOR TRACK
A/P: 240.45 mm
L/W: 0.383 kg/m

PM743

SCREEN DOOR
ADAPTOR
A/P: 106.55 mm
L/W: 0.193 kg/m

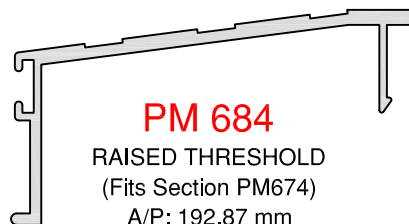

PM 684

RAISED THRESHOLD
(Fits Section PM674)
A/P: 192.87 mm
L/W: 0.394 kg/m



PATH - 9000 SERIES FRAME

SCALE 1:1

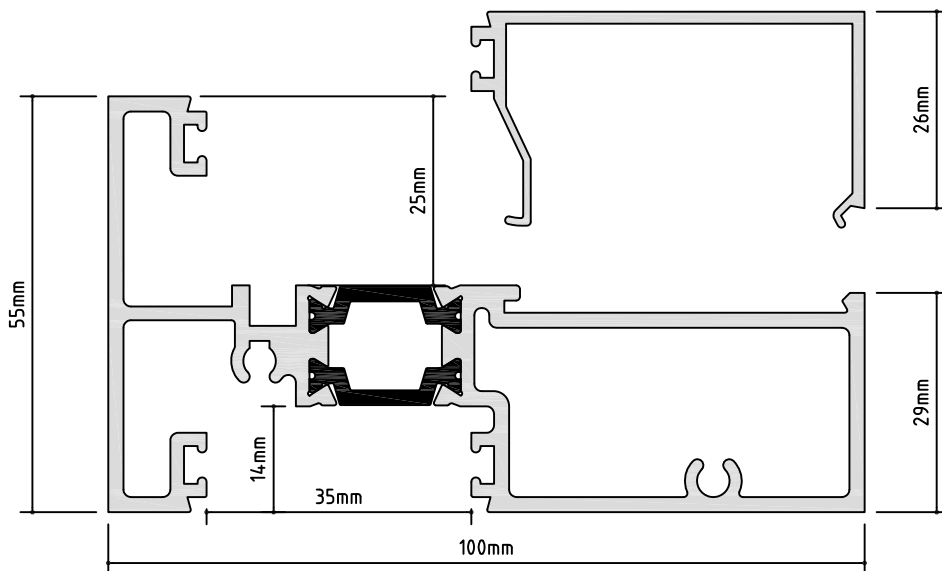
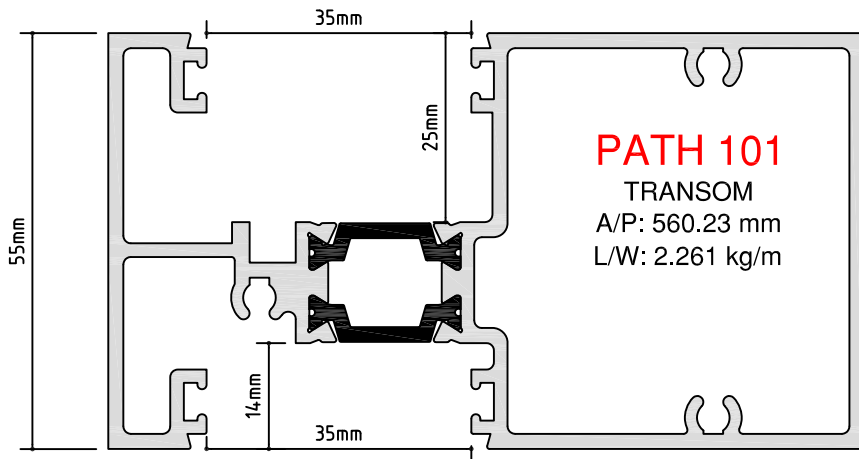
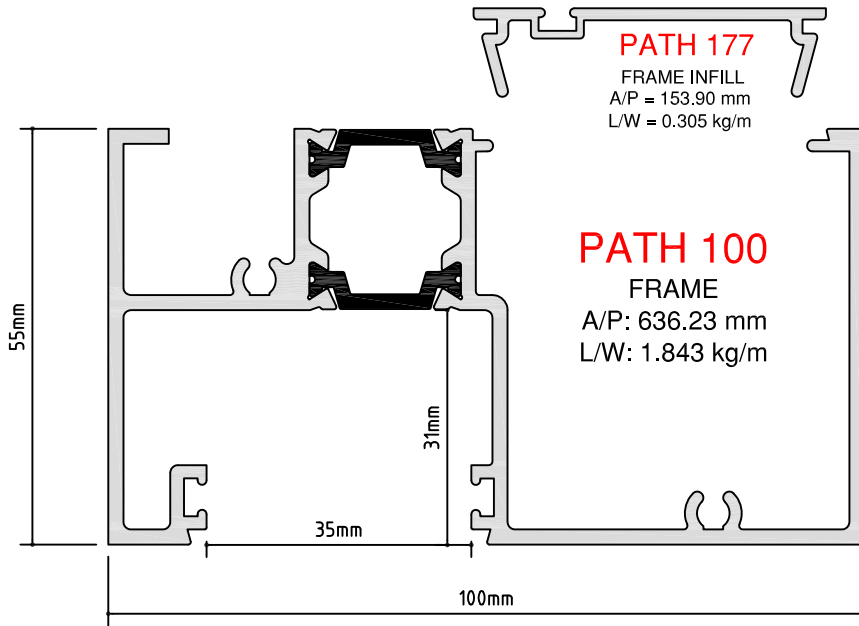

SCALE 1:1

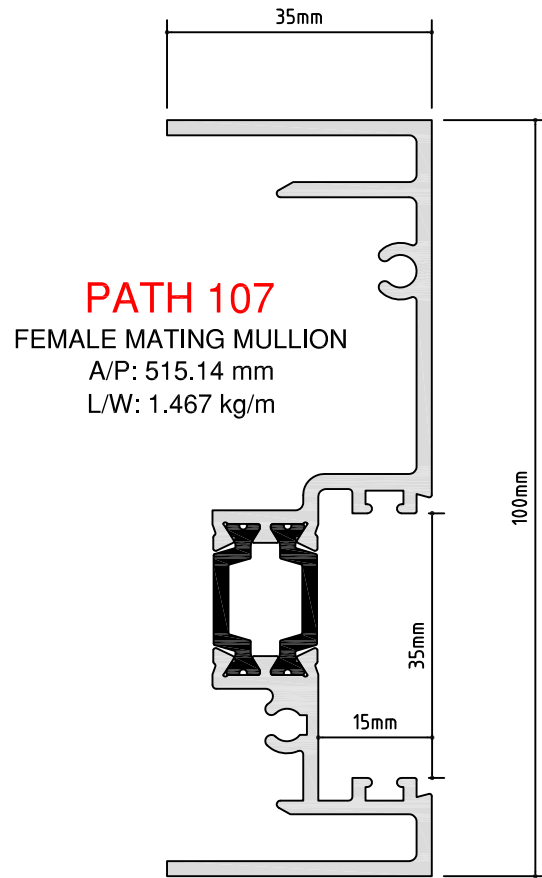
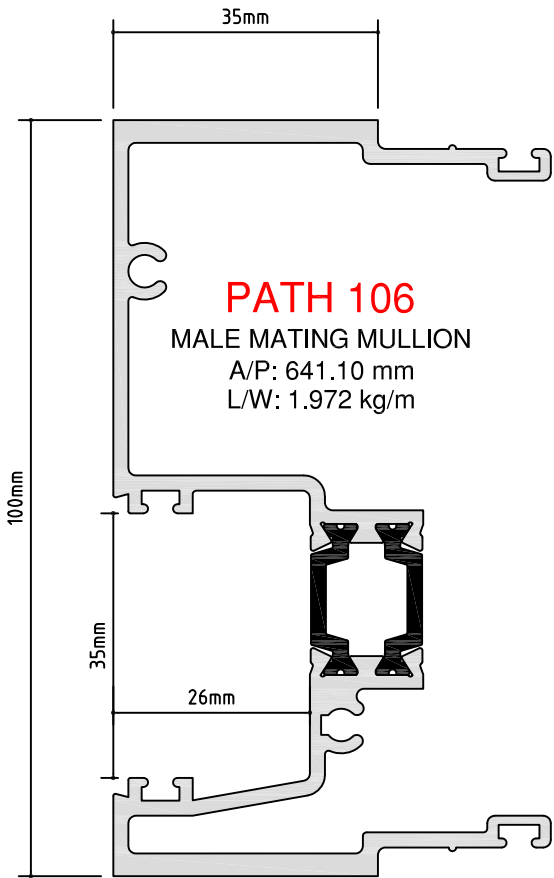

PATH 143
FRAME POCKET FILLER
A/P: 133.26 mm
L/W: 0.295kg/m

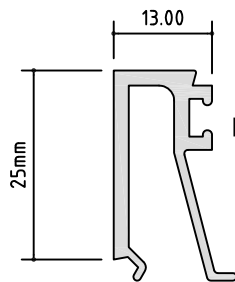
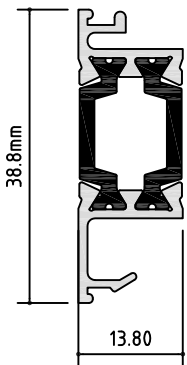

PATH 105
EXTERNAL GLAZING BEAD
A/P: 149.22 mm
L/W: 0.340 kg/m

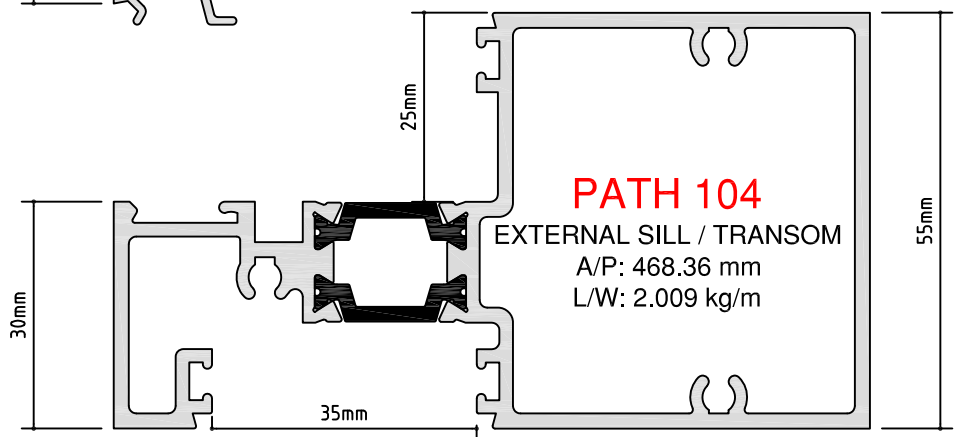
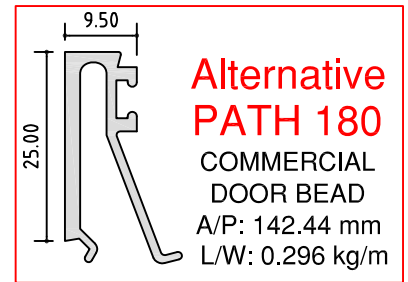



PATH - 9000 SERIES FRAME

SCALE 1:1

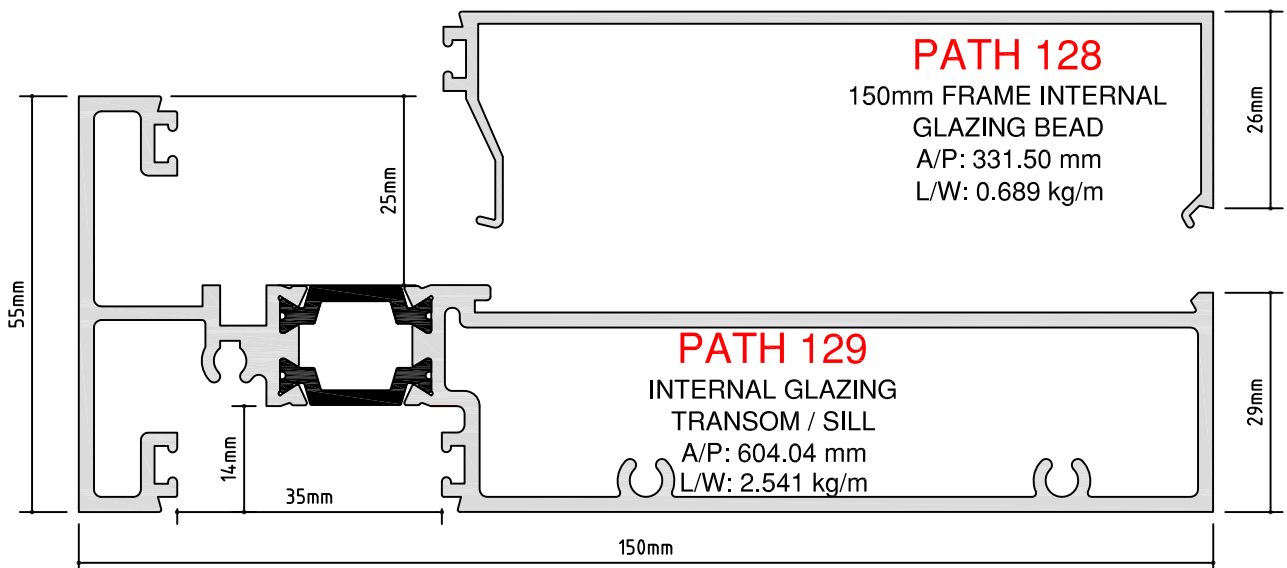
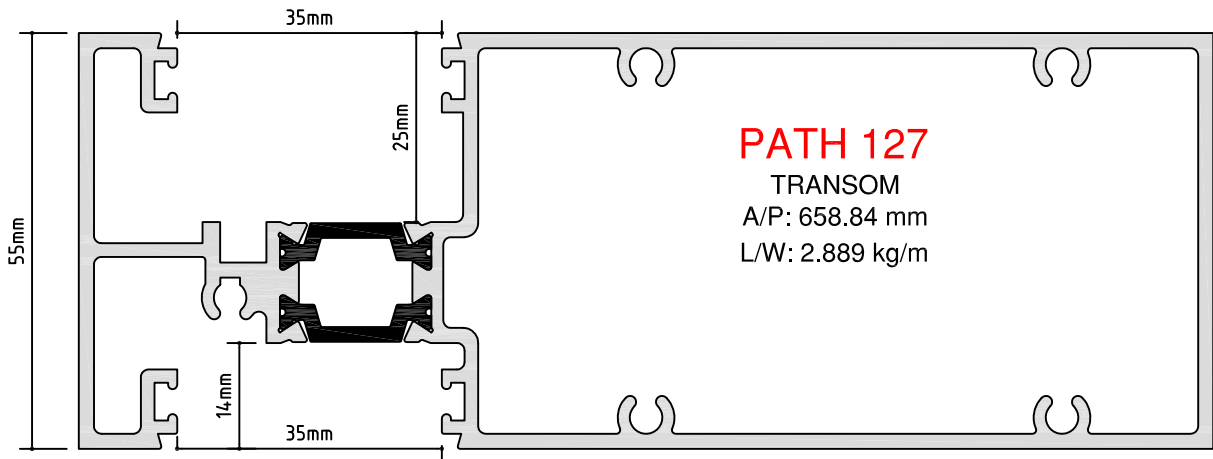
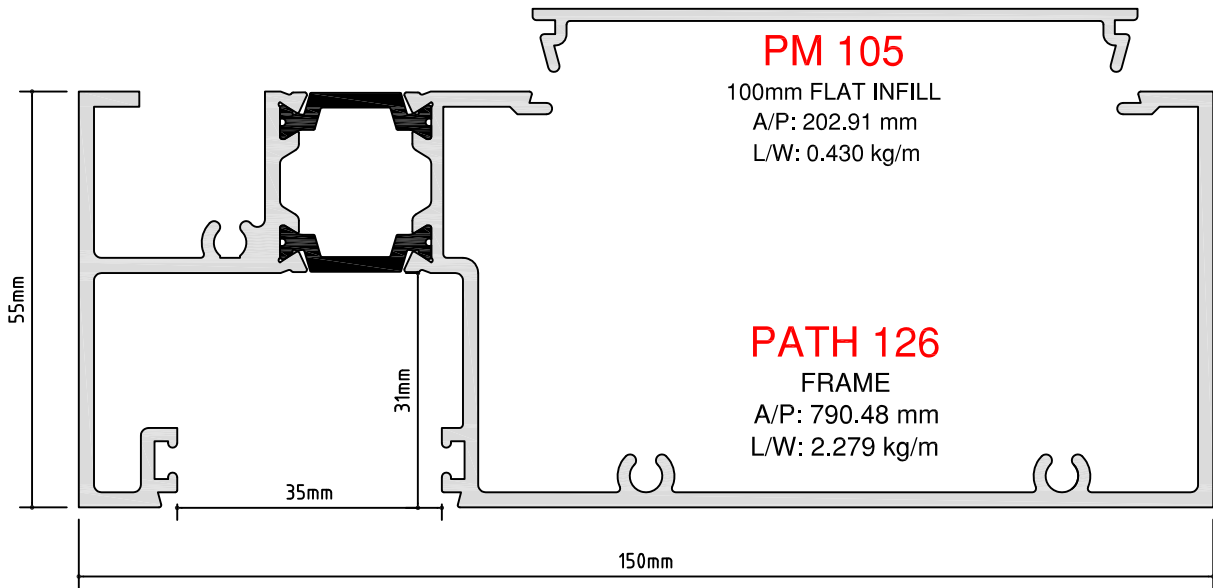

SCALE 1:1

PATH 143

FRAME POCKET FILLER
A/P: 133.26 mm
L/W: 0.295kg/m

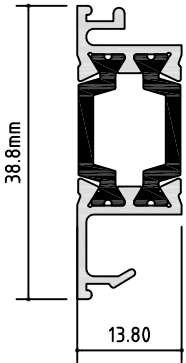

PATH 133

MALE MATING MULLION
A/P: 758.40 mm
L/W: 2.301 kg/m

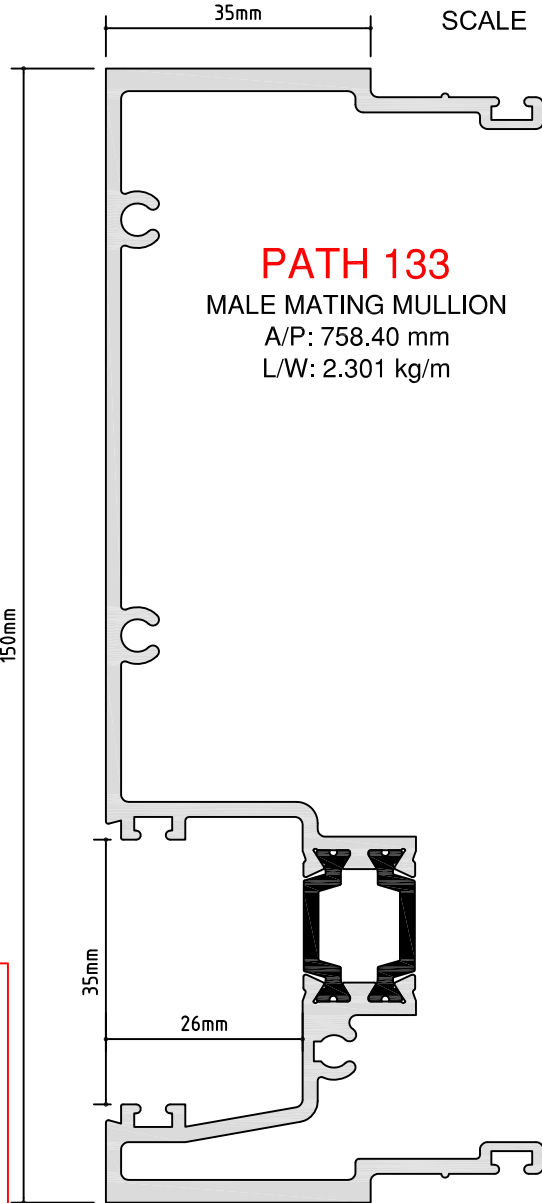

PATH 134

FEMALE MATING MULLION
A/P: 633.62 mm
L/W: 1.778 kg/m

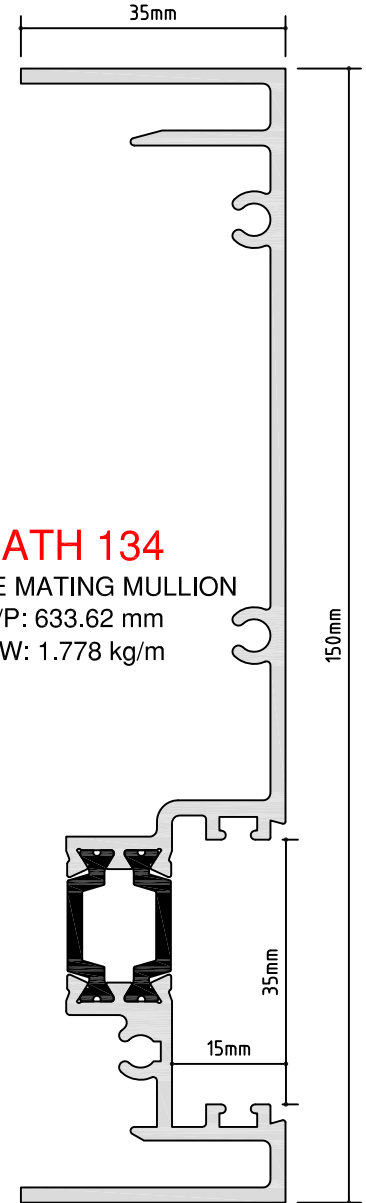

**Alternative
PATH 180**

COMMERCIAL
DOOR BEAD
A/P: 142.44 mm
L/W: 0.296 kg/m

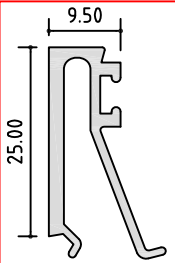

PATH 105

EXTERNAL GLAZING BEAD

A/P: 149.22 mm
L/W: 0.340 kg/m

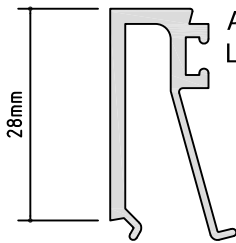

PATH 135

EXTERNAL SILL / TRANSON
A/P: 567.63 mm
L/W: 2.638 kg/m

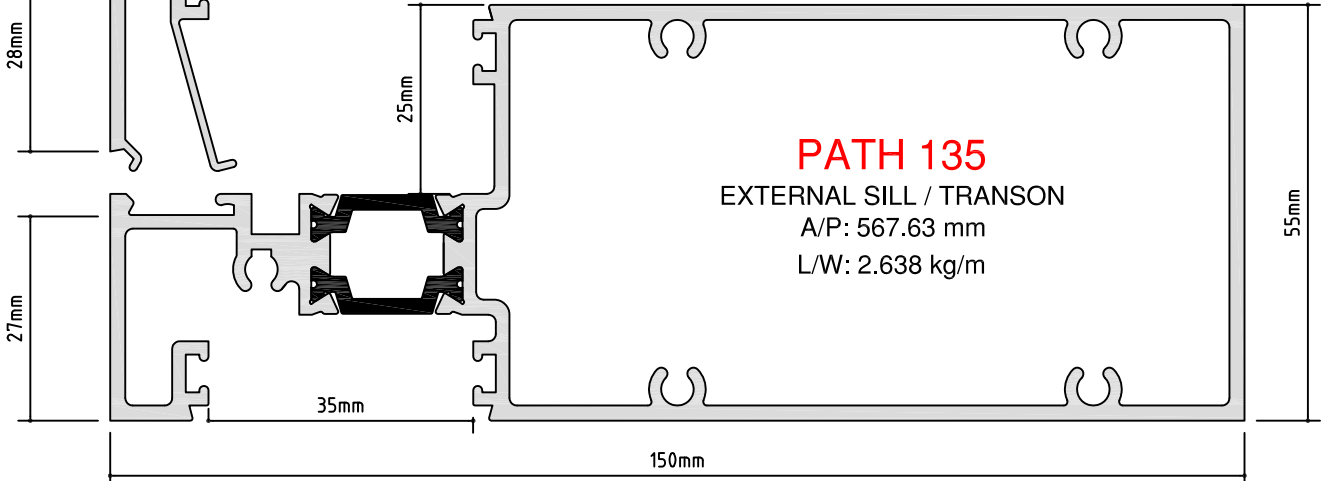



**PATH - 9000 SERIES
50mm AWNING SASH**

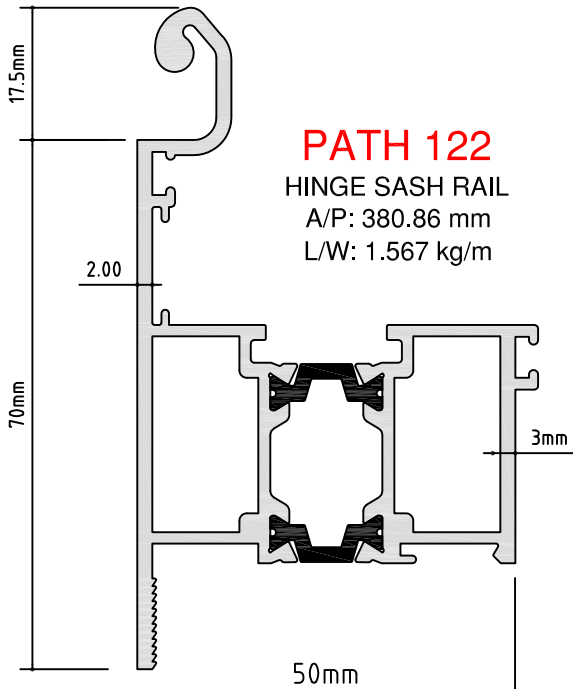

PATH 122

HINGE SASH RAIL
A/P: 380.86 mm
L/W: 1.567 kg/m

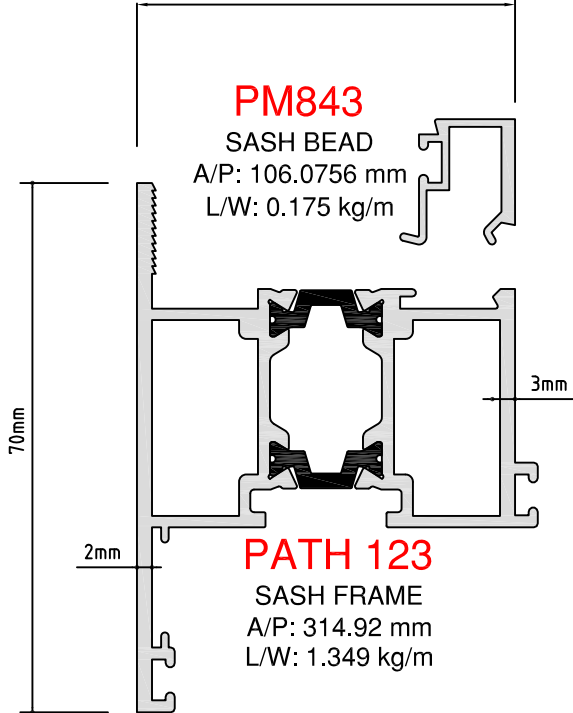

PM843

SASH BEAD
A/P: 106.0756 mm
L/W: 0.175 kg/m

PATH 123

SASH FRAME
A/P: 314.92 mm
L/W: 1.349 kg/m

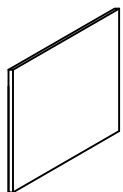

PATH 201

SASH CORNER SLEEVE
(4 Pieces)

** NON STOCK ITEM*

SCALE 1:1

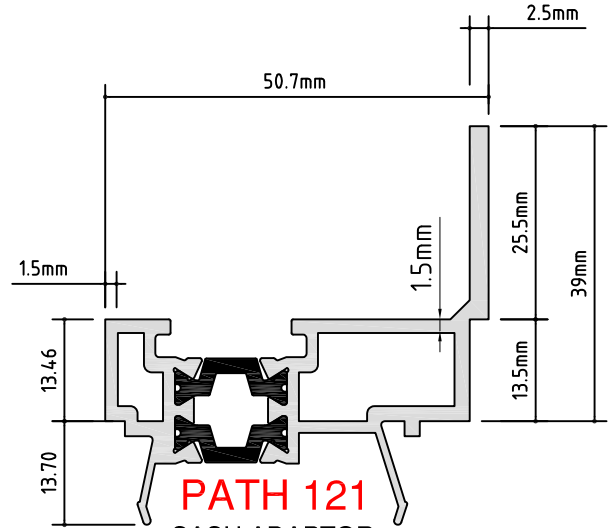

PATH 121

SASH ADAPTOR
A/P: 252.13 mm
L/W: 0.974kg/m

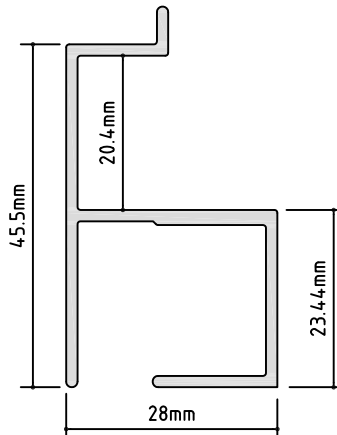

PM344

WINDER / SCREEN
ADAPTOR
A/P: 250.66 mm
L/W: 0.520 kg/m

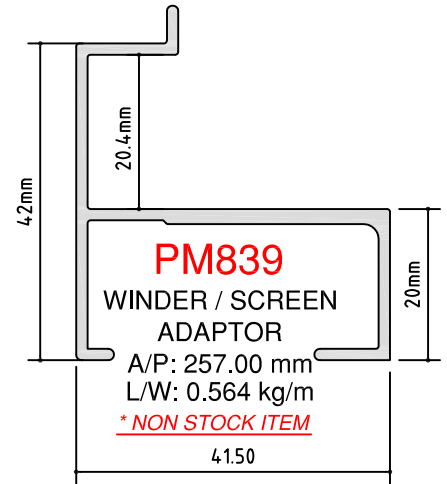

PM839

WINDER / SCREEN
ADAPTOR
A/P: 257.00 mm
L/W: 0.564 kg/m
** NON STOCK ITEM*

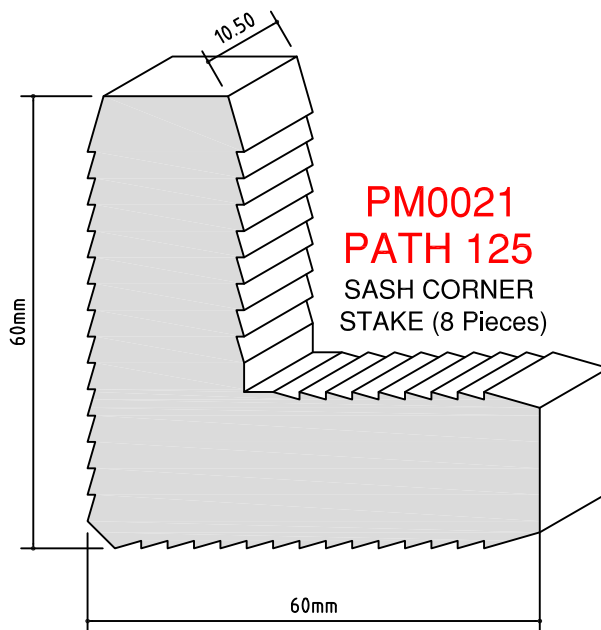

**PM0021
PATH 125**

SASH CORNER
STAKE (8 Pieces)



**PATH - 9000 SERIES
AWNING FRAME**

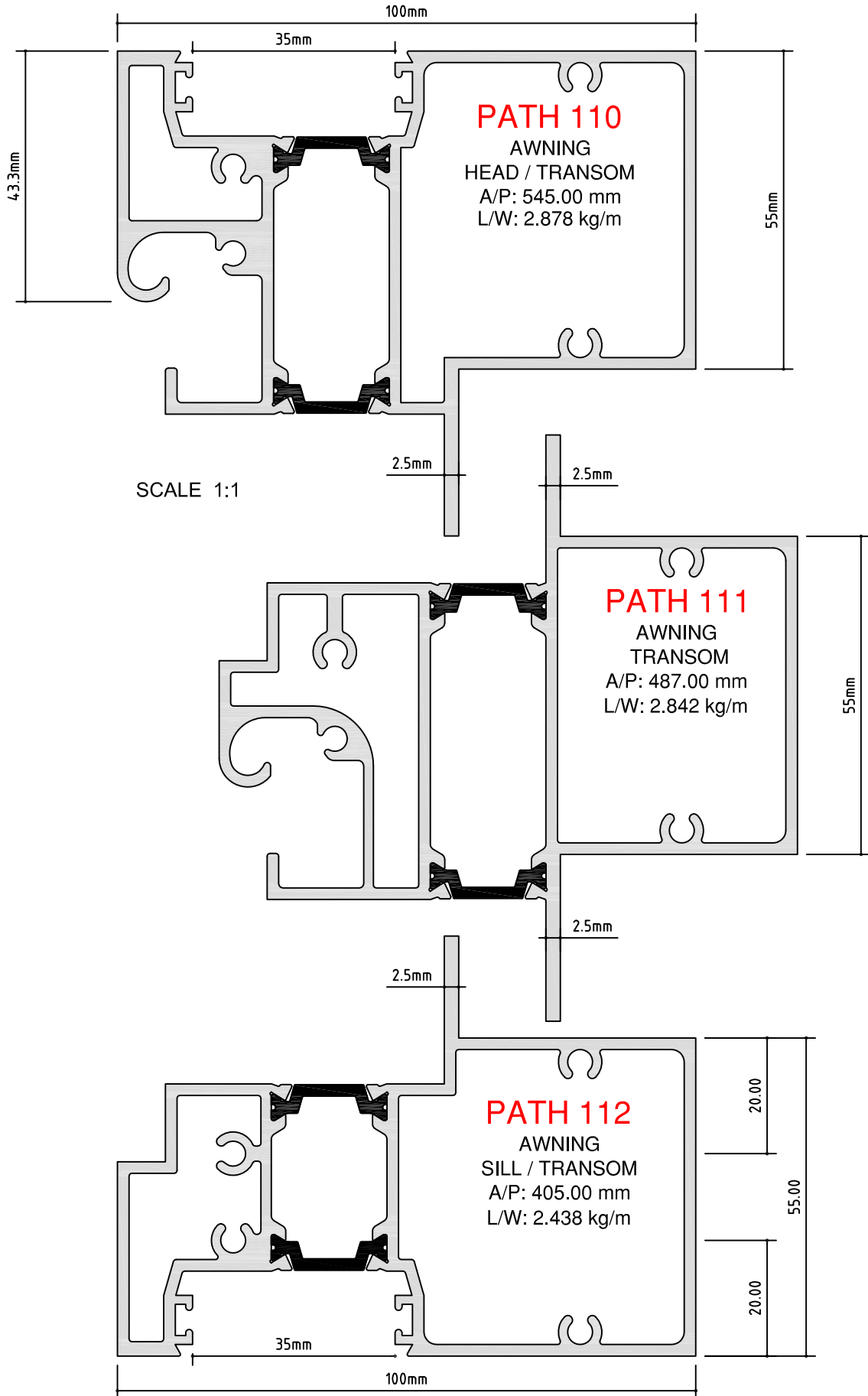



**PATH - 9000 SERIES
AWNING FRAME**

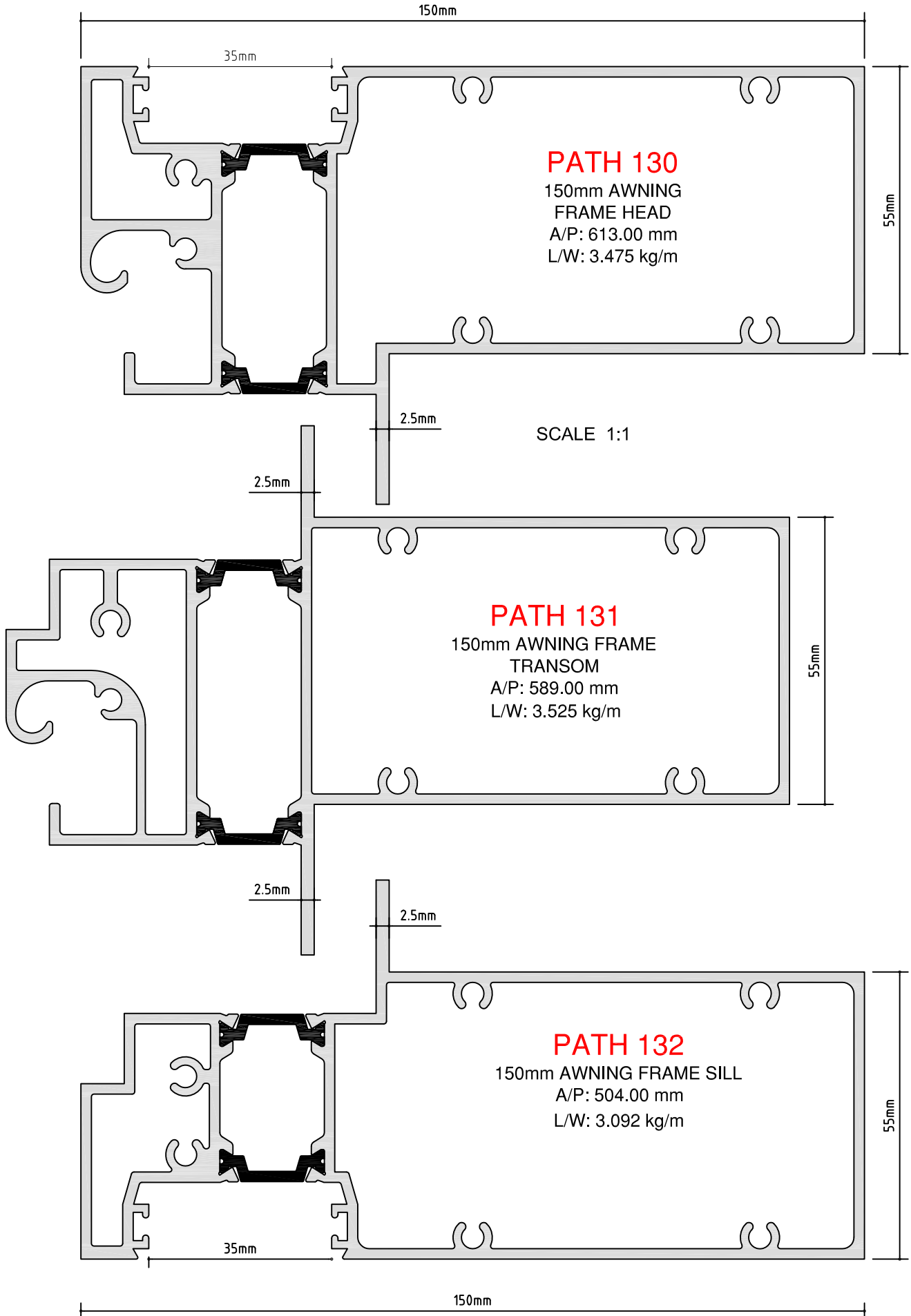



**PATH - 9000 SERIES
50mm COMMERCIAL DOOR**

PATH 180
COMMERCIAL
DOOR BEAD
A/P: 142.44 mm
L/W: 0.296 kg/m

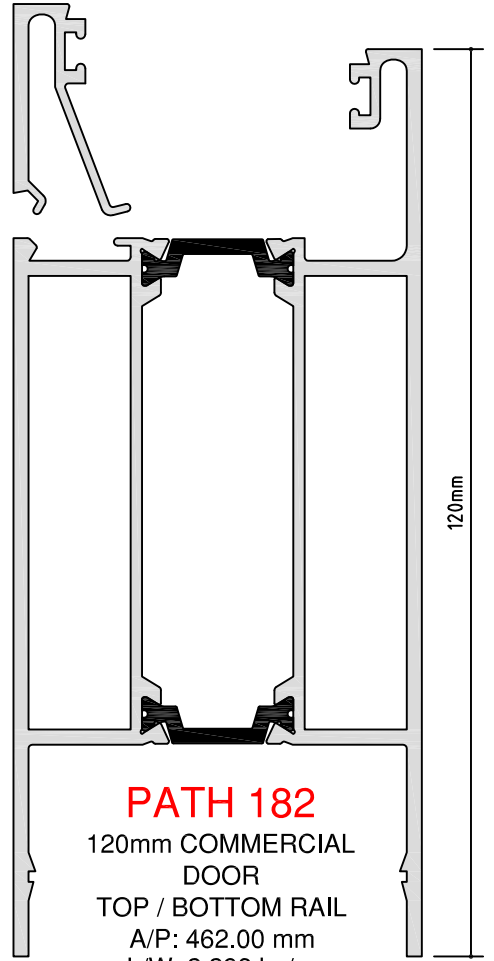

PATH 182
120mm COMMERCIAL
DOOR
TOP / BOTTOM RAIL
A/P: 462.00 mm
L/W: 2.298 kg/m

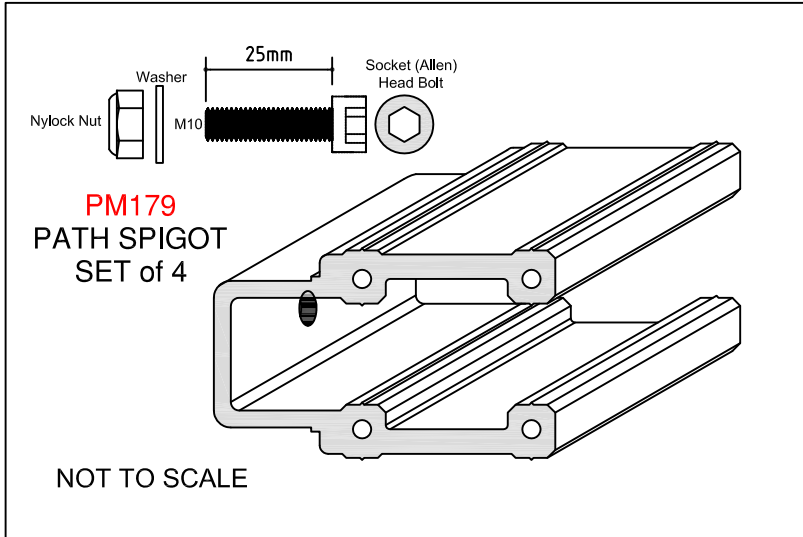

PM179
PATH SPIGOT
SET of 4

NOT TO SCALE

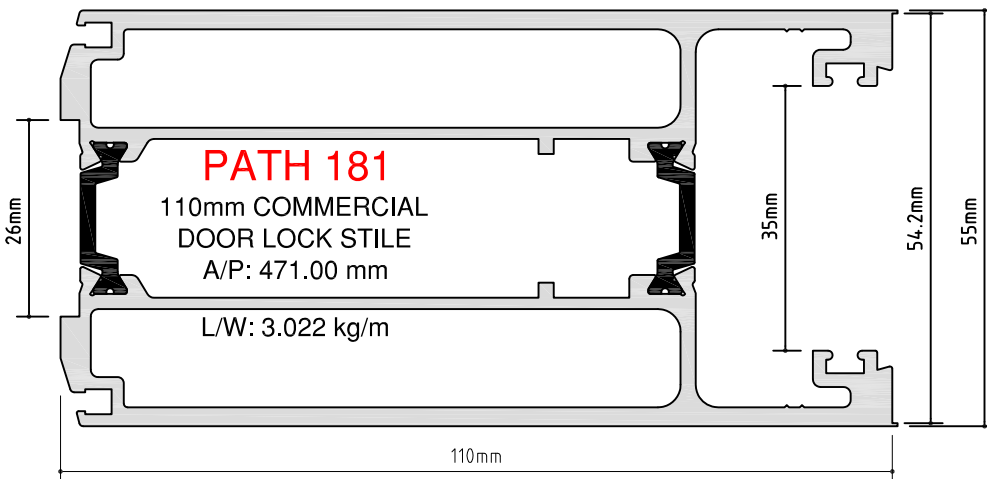

PATH 181
110mm COMMERCIAL
DOOR LOCK STILE
A/P: 471.00 mm
L/W: 3.022 kg/m

SCALE 1:1

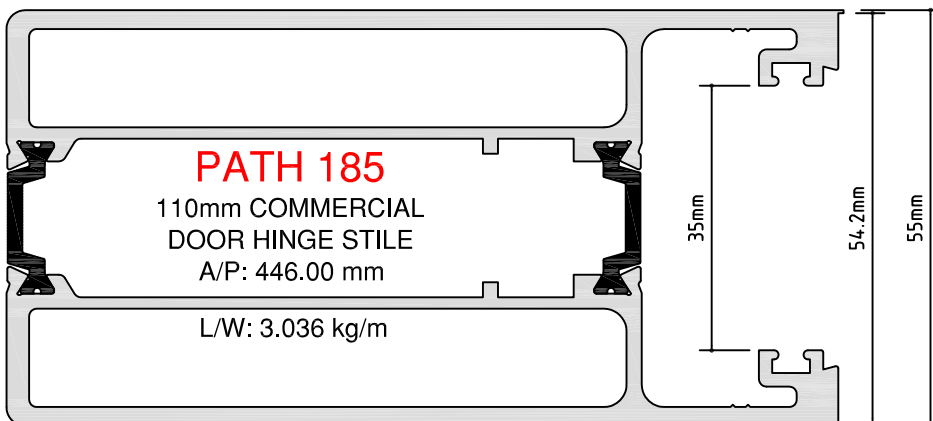

PATH 185
110mm COMMERCIAL
DOOR HINGE STILE
A/P: 446.00 mm
L/W: 3.036 kg/m



**PATH - 9000 SERIES
50mm COMMERCIAL DOOR**

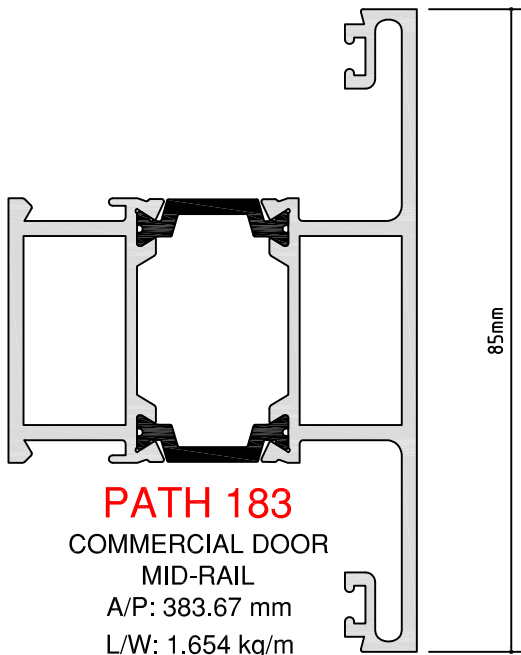

PATH 183
COMMERCIAL DOOR
MID-RAIL
A/P: 383.67 mm
L/W: 1.654 kg/m

SCALE 1:1

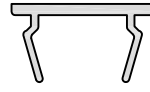

PM 721
UNIVERSAL DOOR
STOP BEAD
A/P: 77.61 mm
L/W: 0.124 kg/m

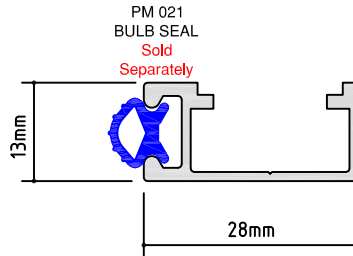

PM 722
UNIVERSAL DOOR
STOP BASE
A/P: 131.36 mm
L/W: 0.255 kg/m

PATH 143
FRAME POCKET FILLER
A/P: 133.26 mm
L/W: 0.295kg/m

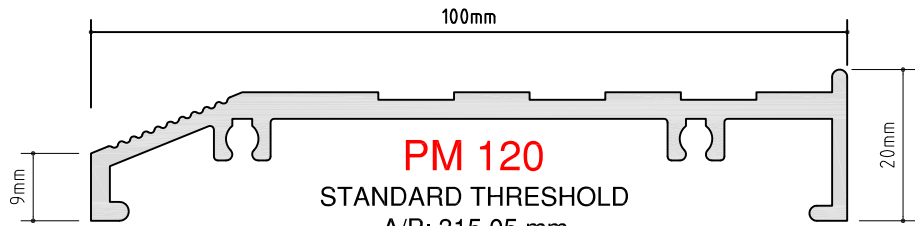
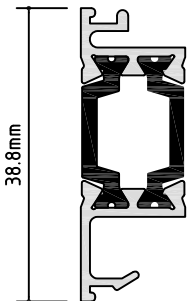

PM 120
STANDARD THRESHOLD
A/P: 315.05 mm
L/W: 1.098 kg/m

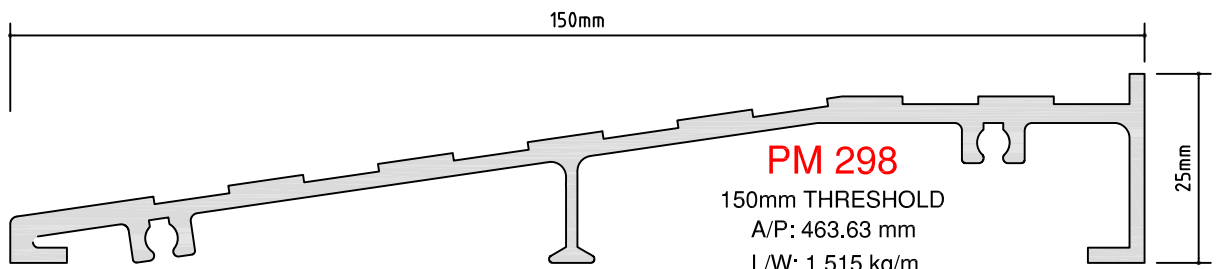

PM 298
150mm THRESHOLD
A/P: 463.63 mm
L/W: 1.515 kg/m



PM 021
DOOR STOP
BULB SEAL

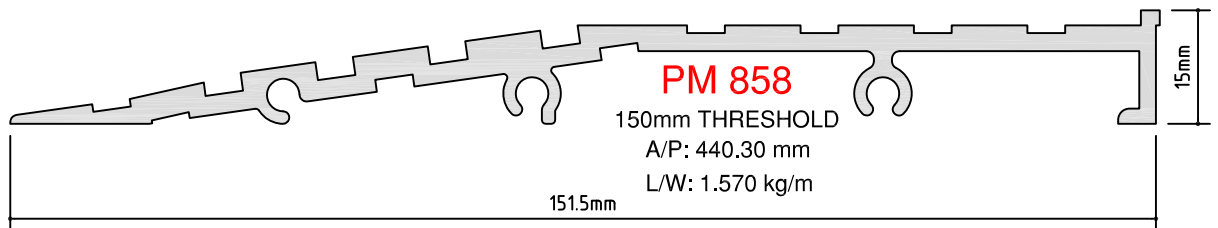

PM 858
150mm THRESHOLD
A/P: 440.30 mm
L/W: 1.570 kg/m

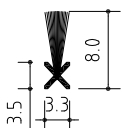

PS-8
POLY-PILE PS SERIES
** NON STOCK ITEM*



**PATH - 9000 SERIES
SLIDING DOOR**

SCALE 1:1

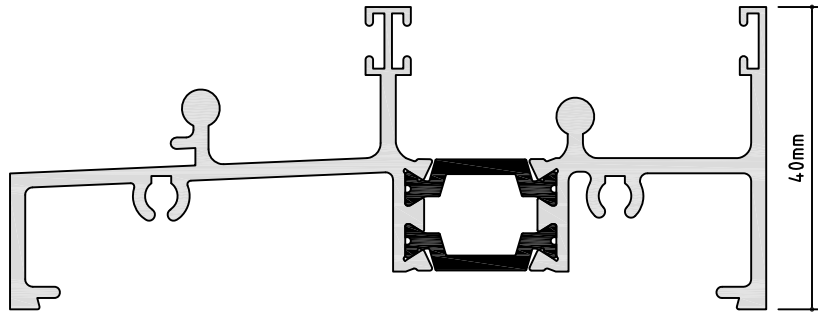

PATH 162
LOW RISE
SILL / TRANSOM
A/P: 520.27 mm
L/W: 1.405 kg/m

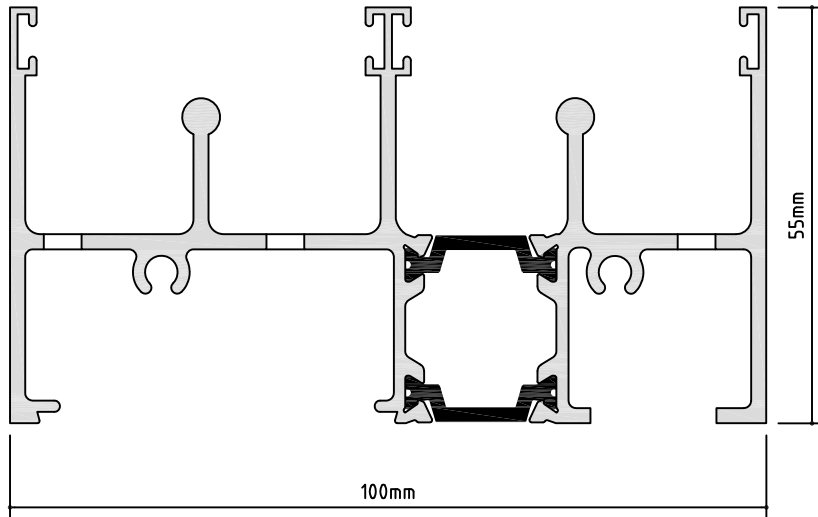

PATH 161
STANDARD S-DOOR SILL
A/P: 736.64 mm

L/W: 1.974 kg/m

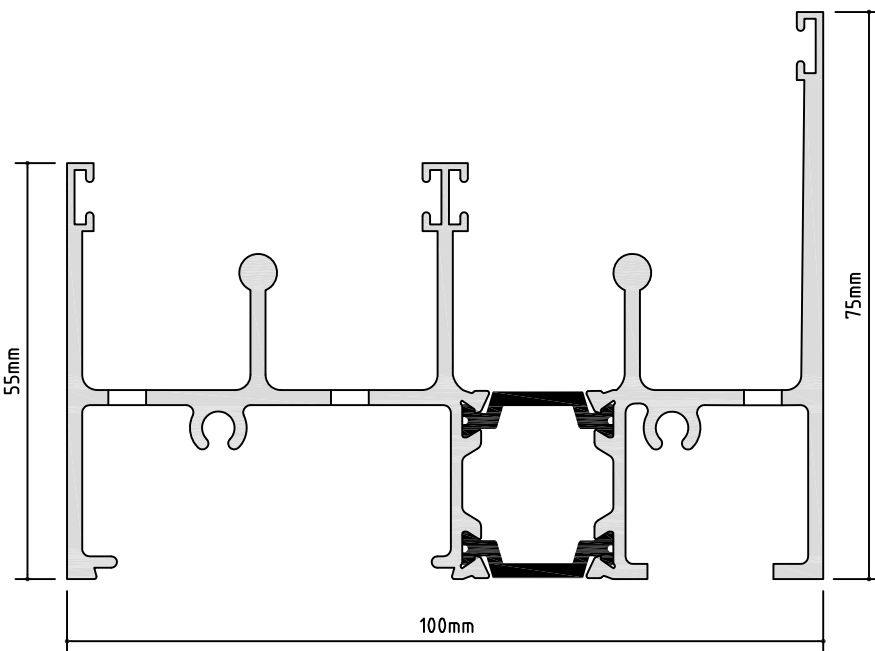

PATH 159
HIGH S-DOOR SILL
A/P: 764.32 mm
L/W: 2.161 kg/m



**PATH - 9000 SERIES
SLIDING DOOR**

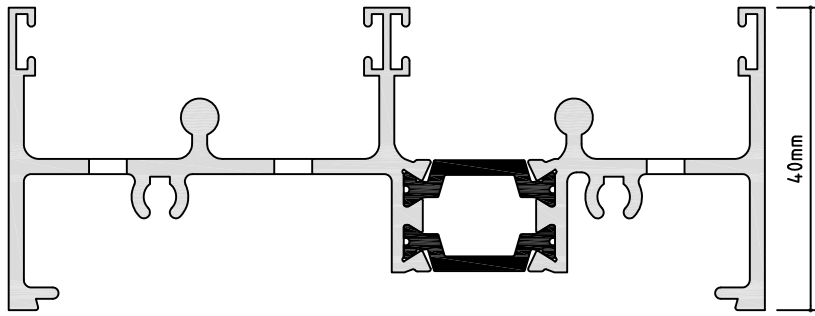

SCALE 1:1

PATH 160
S-WINDOW LOW LITE
SILL / TRANSOM
A/P: 587.05 mm
L/W: 1.522 kg/m

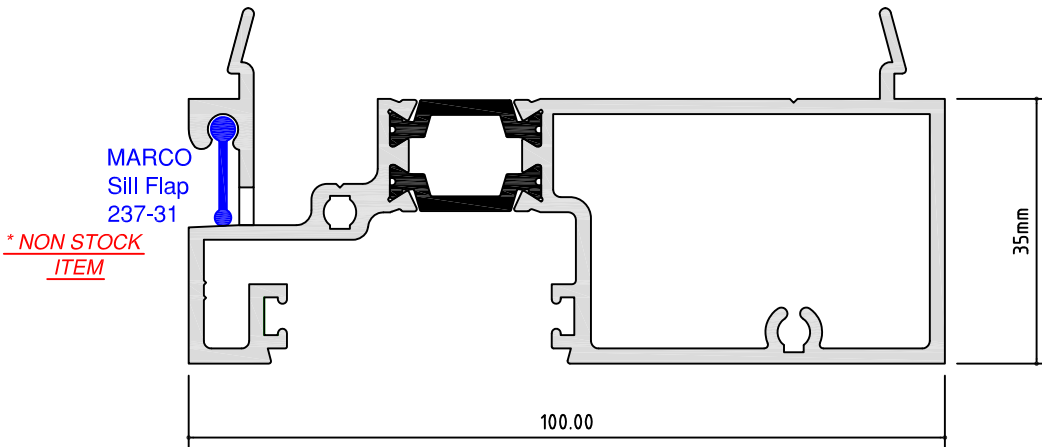

PATH 163
S-WINDOW LOW LITE
TRANSOM ADAPTOR
A/P: 473.56 mm
L/W: 1.875 kg/m

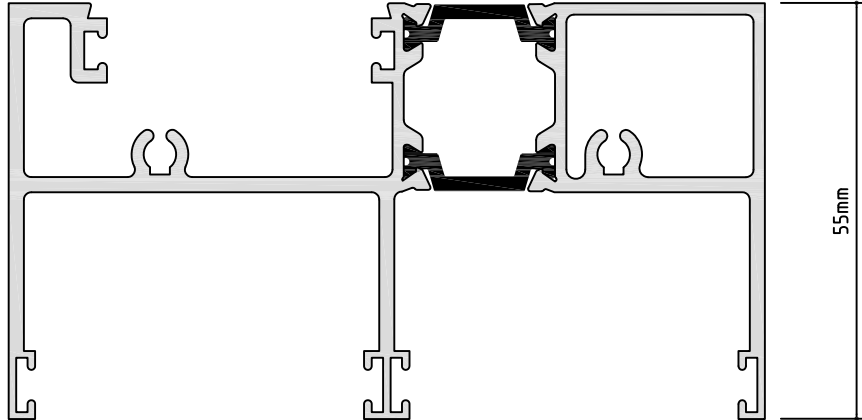

PATH 164
S-DOOR HEAD /TRANSOM
A/P: 614.13 mm
L/W: 1.853 kg/m

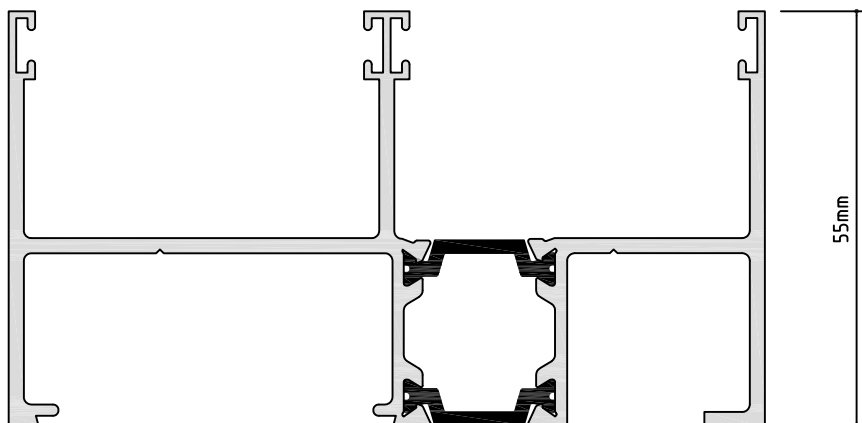

PATH 165
S-DOOR JAMB
A/P: 600.78 mm
L/W: 1.589 kg/m



**PATH - 9000 SERIES
SLIDING DOOR**

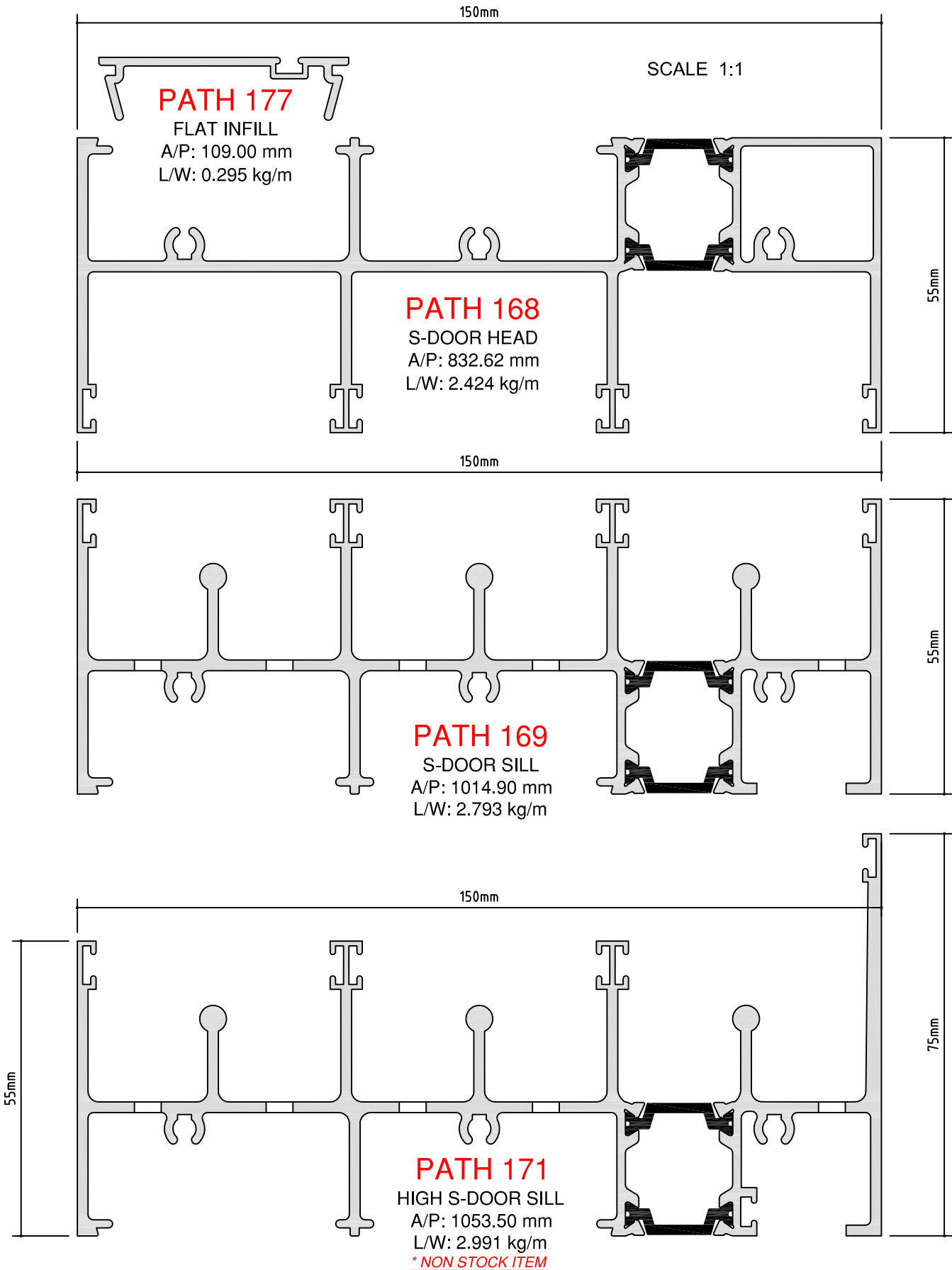



**PATH - 9000 SERIES
SLIDING DOOR**

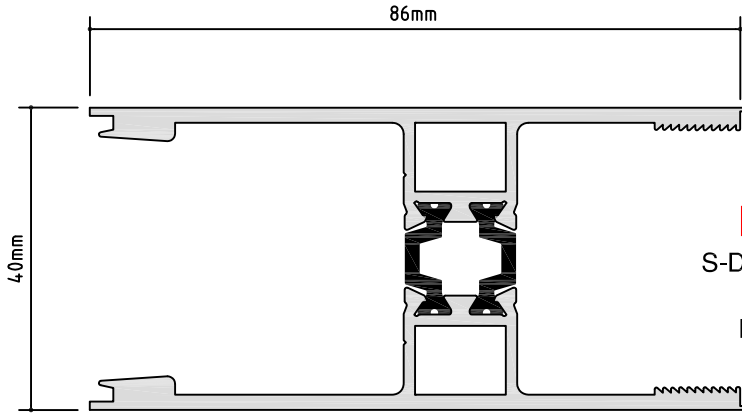

SCALE 1:1

PATH 149

S-DOOR PLAIN STILE

A/P: 432.04 mm

L/W: 1.466 kg/m

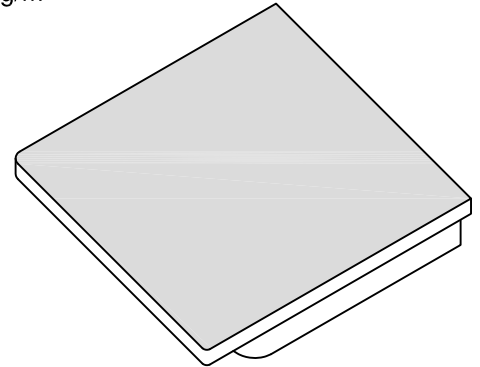

PM 075

STILE CAP

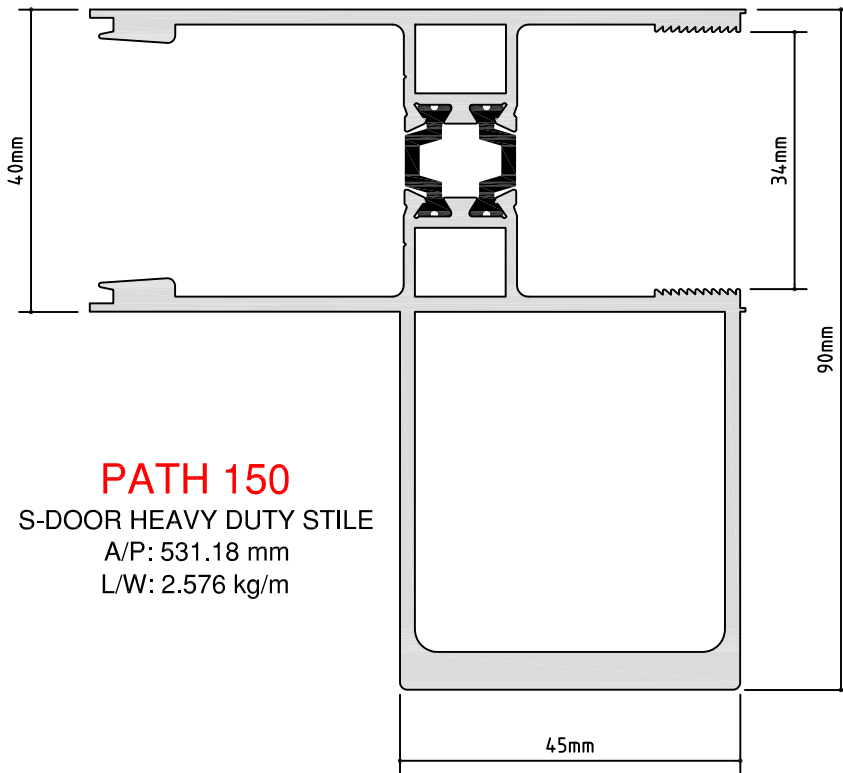

PATH 150

S-DOOR HEAVY DUTY STILE

A/P: 531.18 mm

L/W: 2.576 kg/m

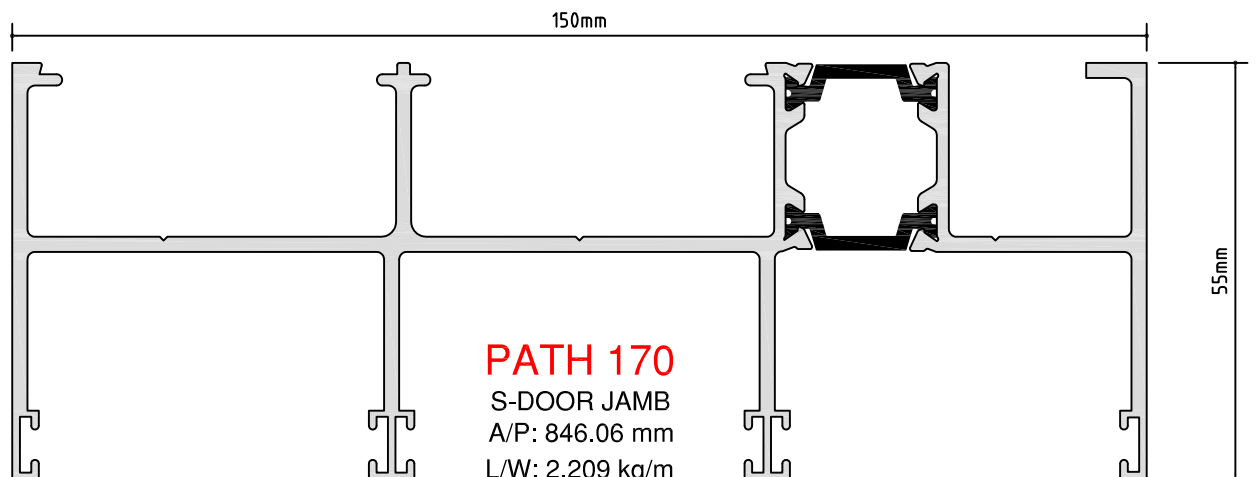

PATH 170

S-DOOR JAMB

A/P: 846.06 mm

L/W: 2.209 kg/m



**PATH - 9000 SERIES
SLIDING DOOR**

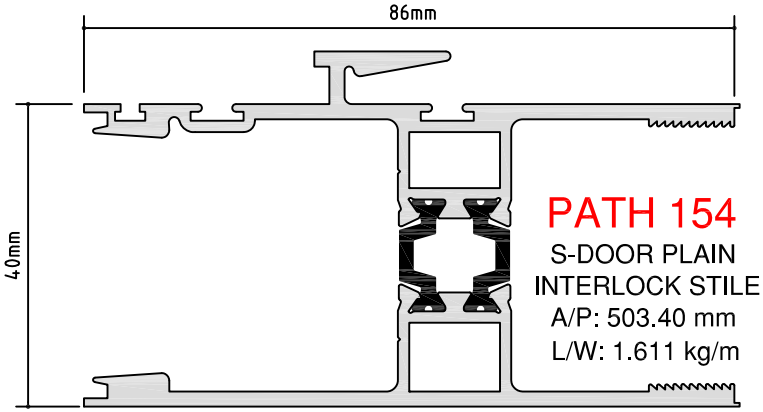

SCALE 1:1

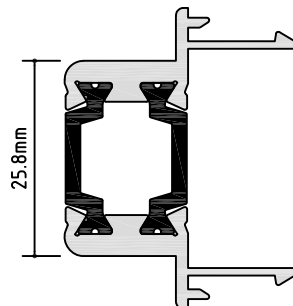
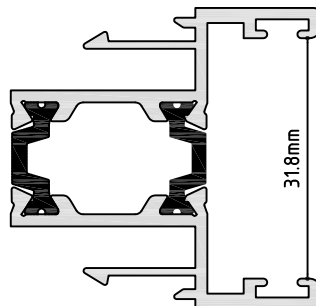
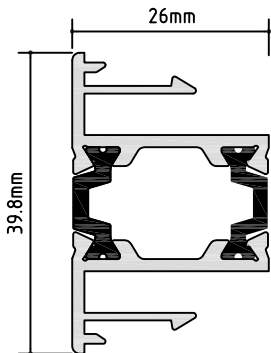
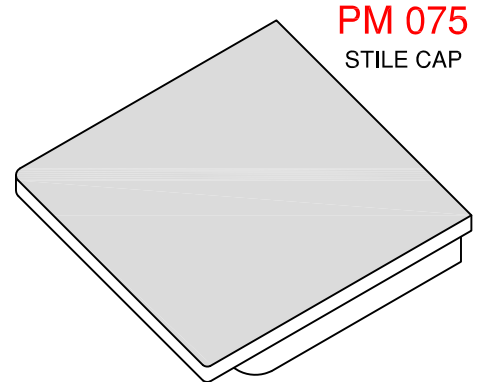
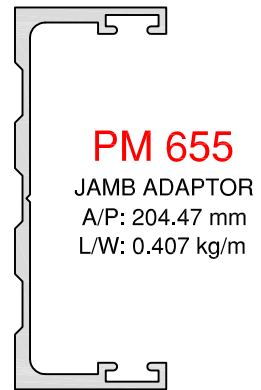
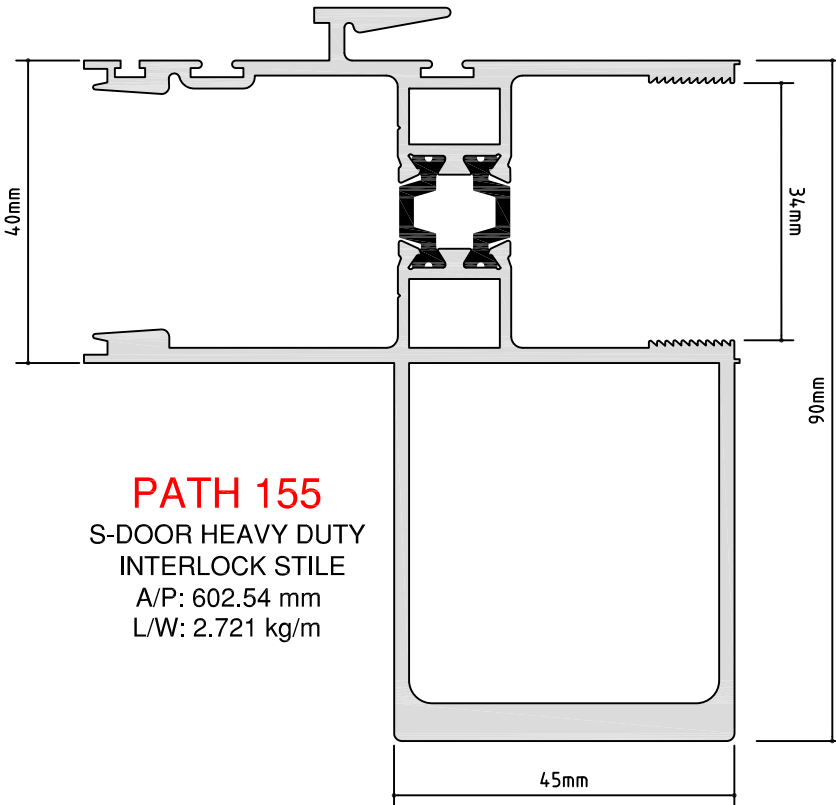
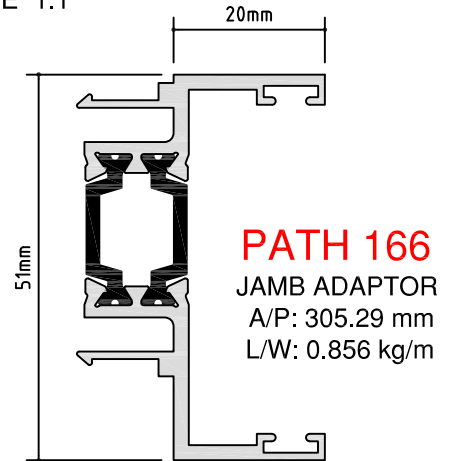

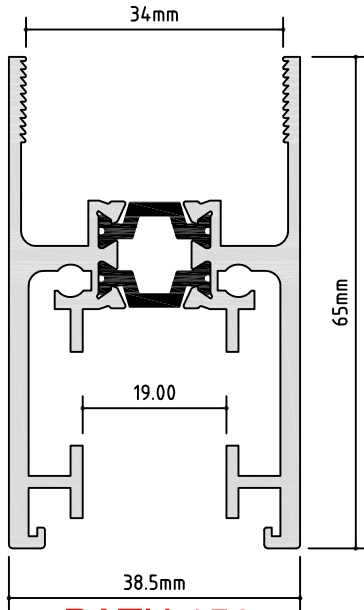

PATH 156
S-DOOR STANDARD RAIL
A/P: 485.53 mm
L/W: 1.411 kg/m

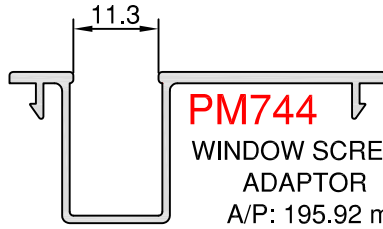

PM744
WINDOW SCREEN
ADAPTOR
A/P: 195.92 mm
L/W: 0.317 kg/m

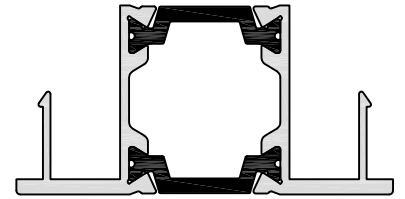

PATH 158
TB TRACK INFILL
A/P: 197.40 mm
L/W: 0.518 kg/m

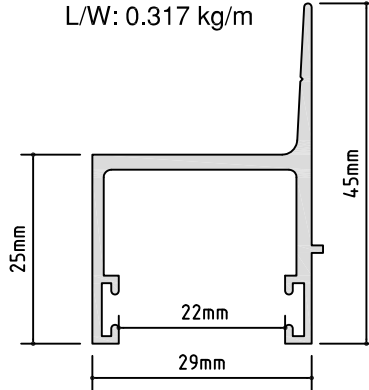

PM 445
SINGLE HEAD TRACK
ADAPTOR
A/P: 221.01 mm
L/W: 0.471 kg/m

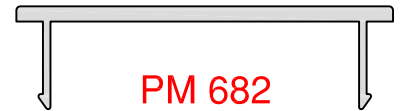

PM 682
PLAIN TRACK INFILL
A/P: 149.84 mm
L/W: 0.334 kg/m

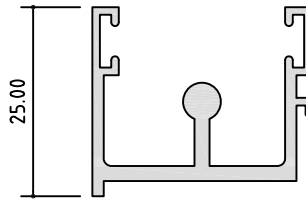

PM 447
SINGLE SILL TRACK
ADAPTOR
A/P: 204.15 mm
L/W: 0.436 kg/m



PM 685
FLAT THRESHOLD
A/P: 154.76 mm
L/W: 0.319 kg/m

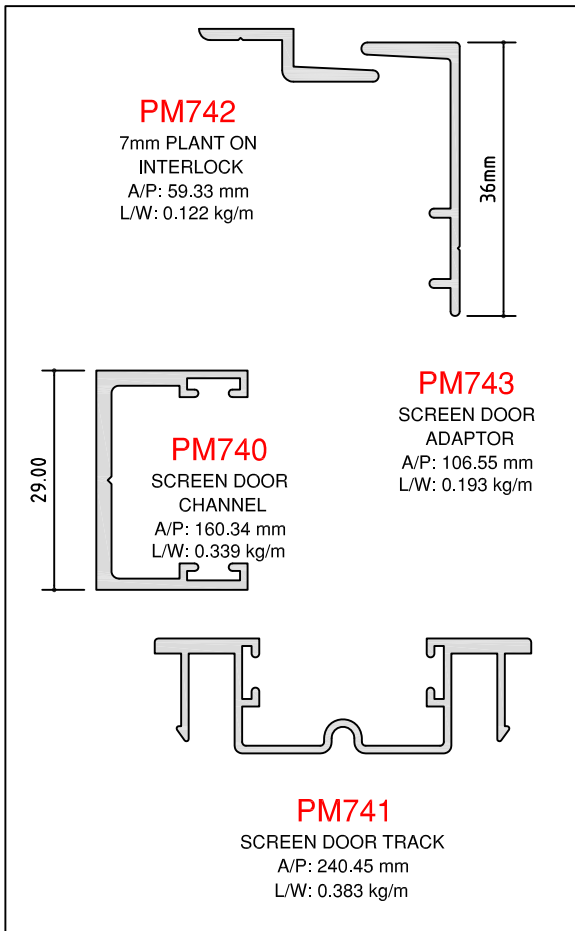

PM742
7mm PLANT ON
INTERLOCK
A/P: 59.33 mm
L/W: 0.122 kg/m

PM740
SCREEN DOOR
CHANNEL
A/P: 160.34 mm
L/W: 0.339 kg/m

PM743
SCREEN DOOR
ADAPTOR
A/P: 106.55 mm
L/W: 0.193 kg/m

PM741
SCREEN DOOR TRACK
A/P: 240.45 mm
L/W: 0.383 kg/m

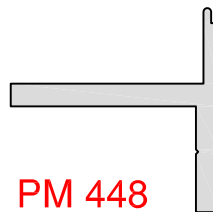

PM 448
TRACK SUPPORT
A/P: 108.82 mm
L/W: 0.385 kg/m



PM 657
LIPPED THRESHOLD
A/P: 160.33 mm
L/W: 0.350 kg/m

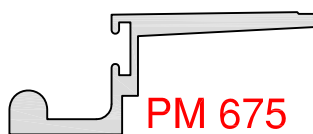

PM 675
LOW PROFILE SILL
SCREEN ADAPTOR
A/P: 127.75 mm
L/W: 0.357 kg/m
(Suits PM 160 Low Profile Sill)

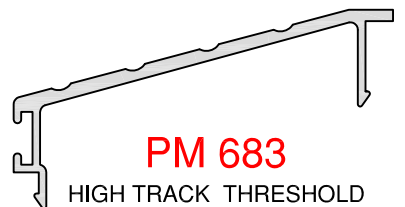

PM 683
HIGH TRACK THRESHOLD
(Fits Section PATH159 & 171)
A/P: 170.22 mm
L/W: 0.331 kg/m

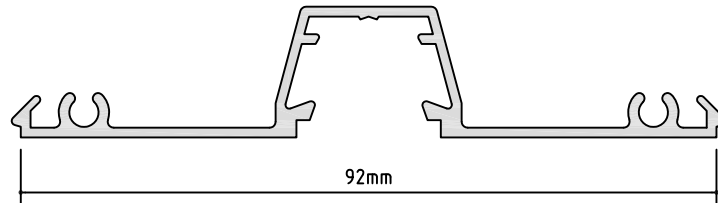
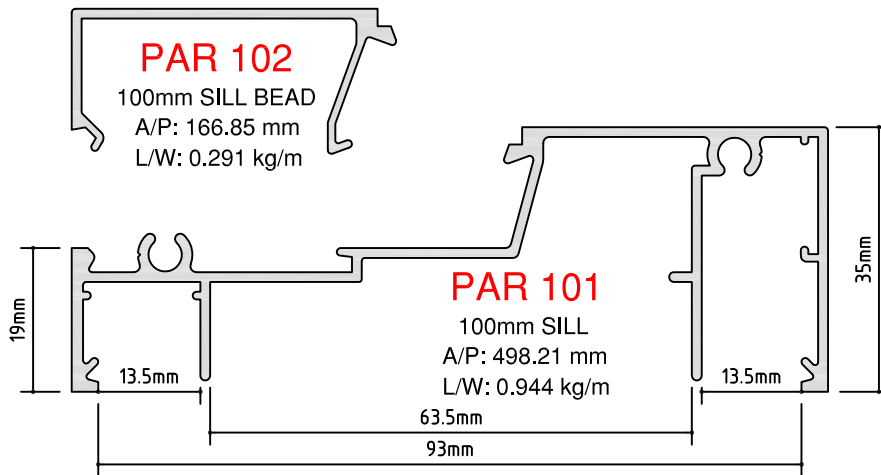
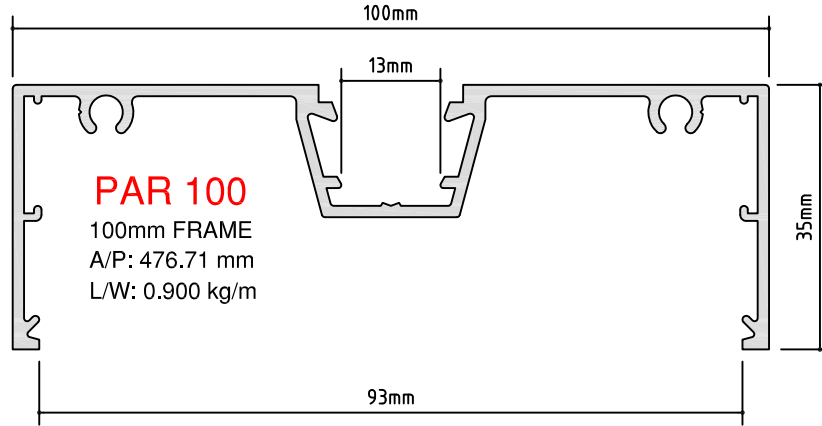

PAR 103
100mm GLAZING ADAPTOR
A/P: 313.92 mm
L/W: 0.607 kg/m

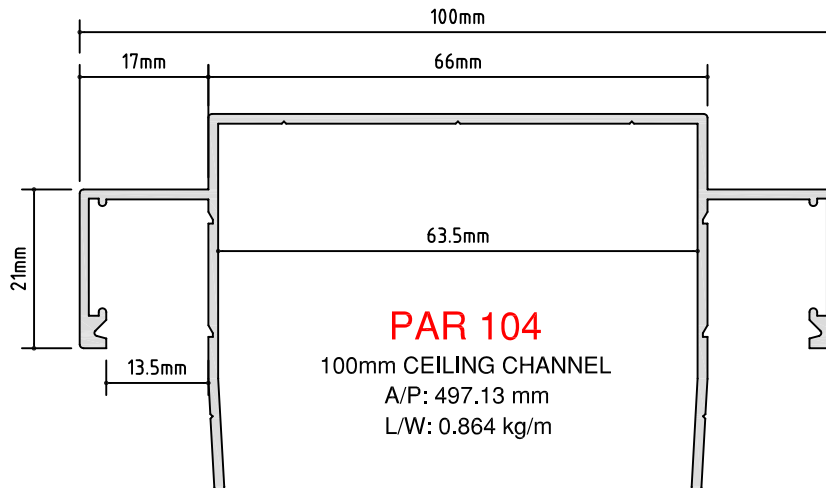

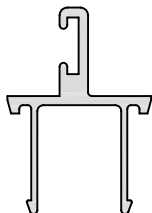
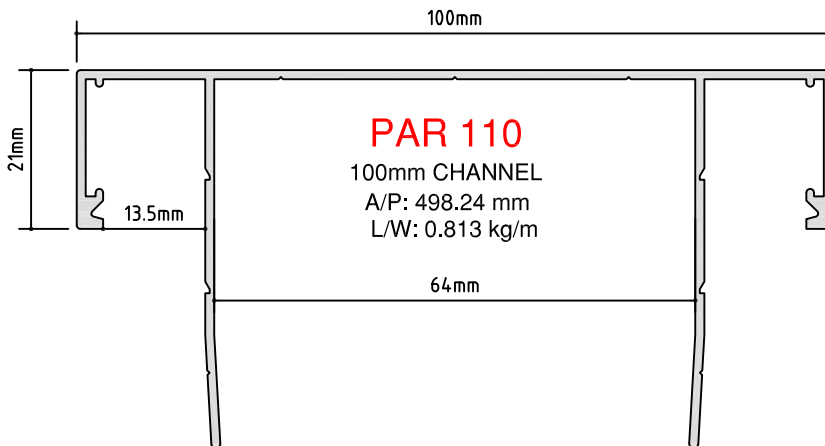
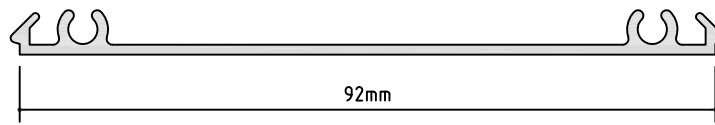
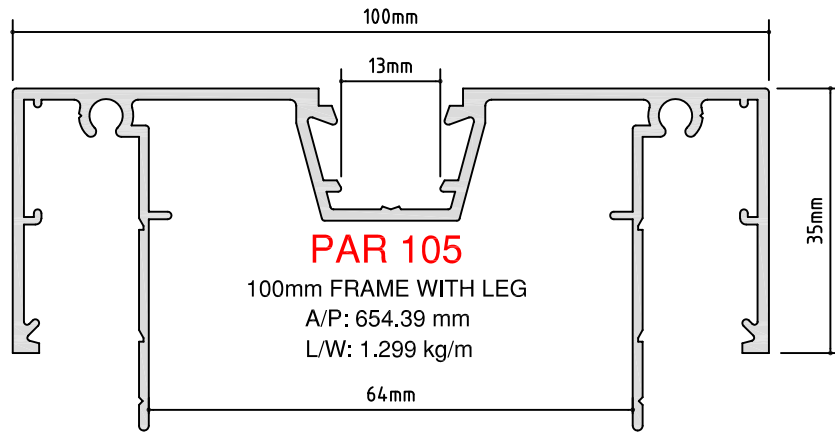

PAR 106
45mm DOOR STOP
A/P: 133.18 mm
L/W: 0.210 kg/m

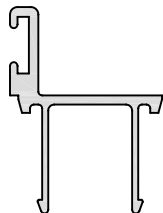

PAR 107
35mm DOOR STOP
A/P: 135.28 mm
L/W: 0.210 kg/m

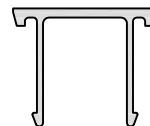

PAR 108
POCKET INFILL
A/P: 99.92 mm
L/W: 0.151 kg/m

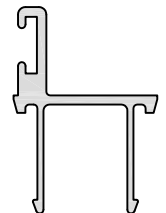

PAR 111
38mm DOOR STOP
A/P: 133.18 mm
L/W: 0.210 kg/m

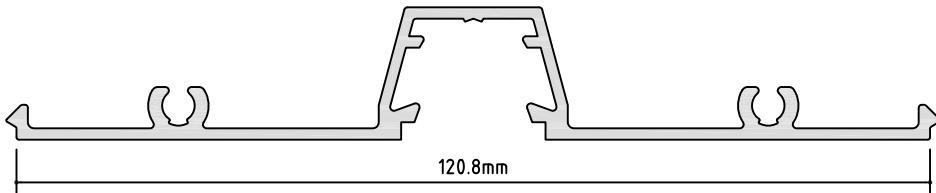
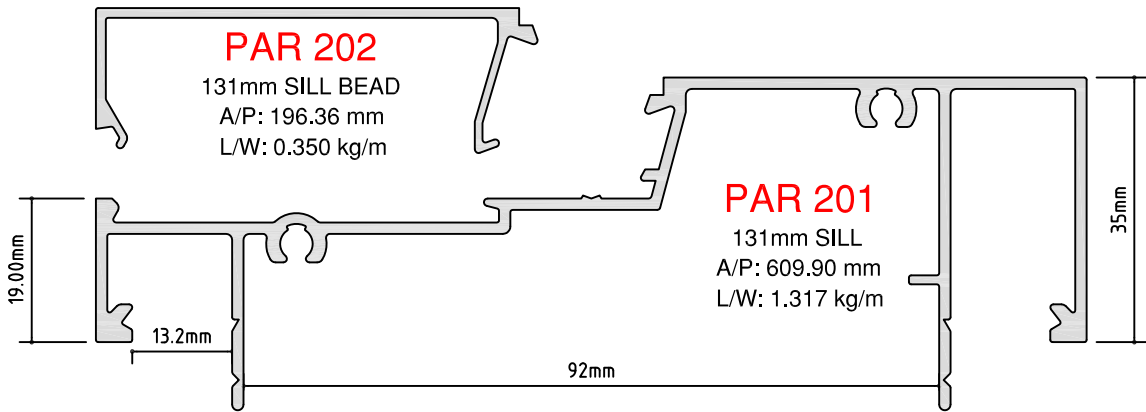
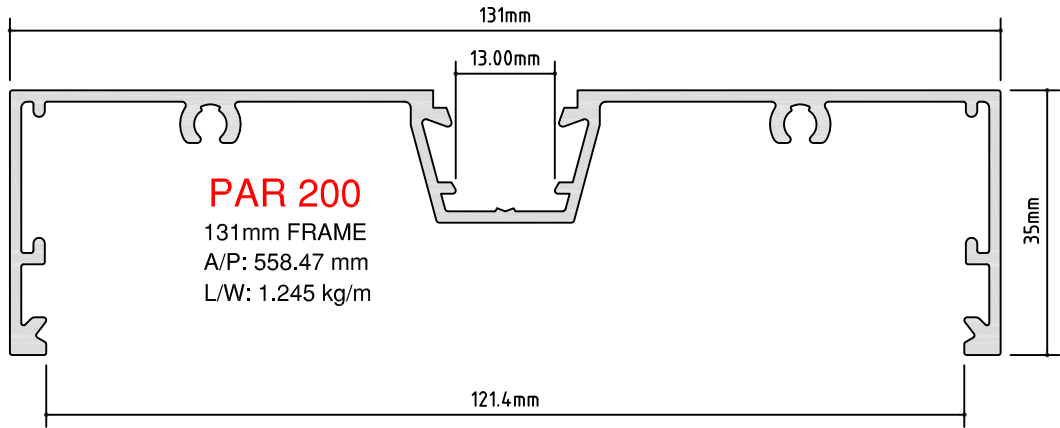

PAR 203
131mm GLAZING ADAPTOR
A/P: 375.76 mm
L/W: 0.833 kg/m

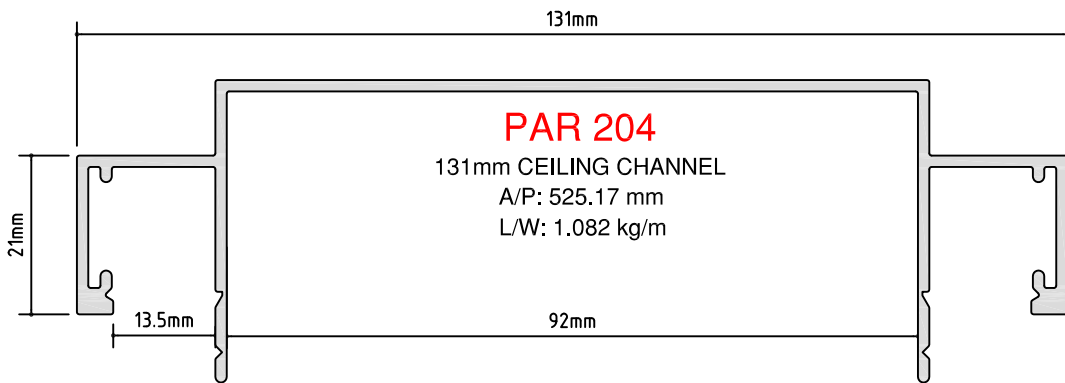

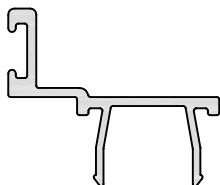
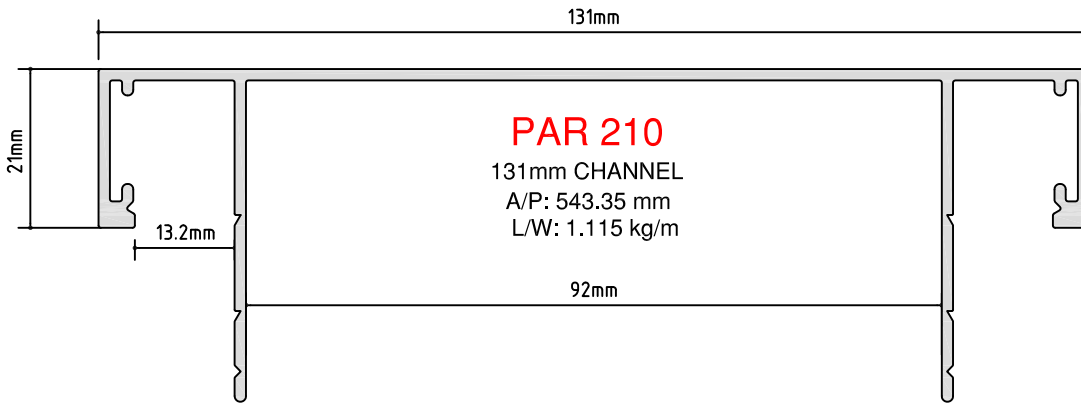
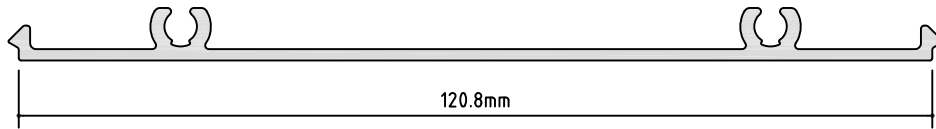
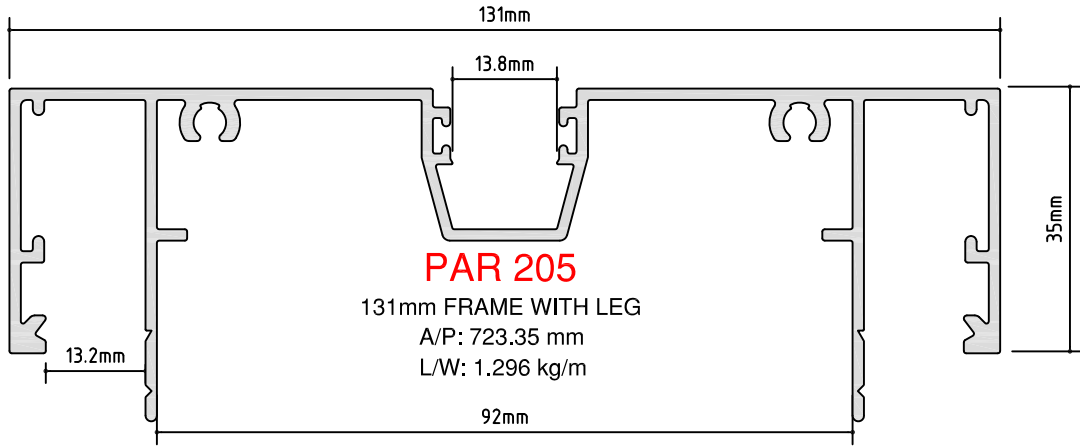

PAR 206
45mm DOOR STOP
A/P: 132.19 mm
L/W: 0.227 kg/m

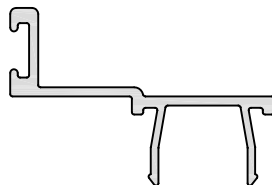

PAR 207
38mm DOOR STOP
A/P: 146.19 mm
L/W: 0.250 kg/m

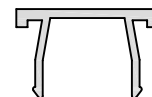

PAR 208
POCKET INFILL
A/P: 85.70 mm
L/W: 0.132 kg/m

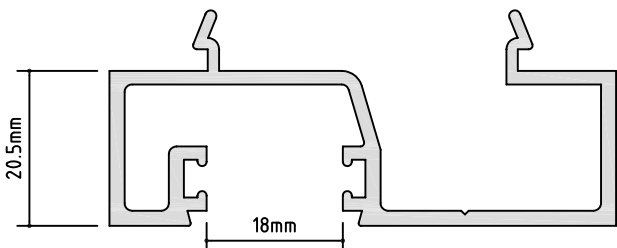
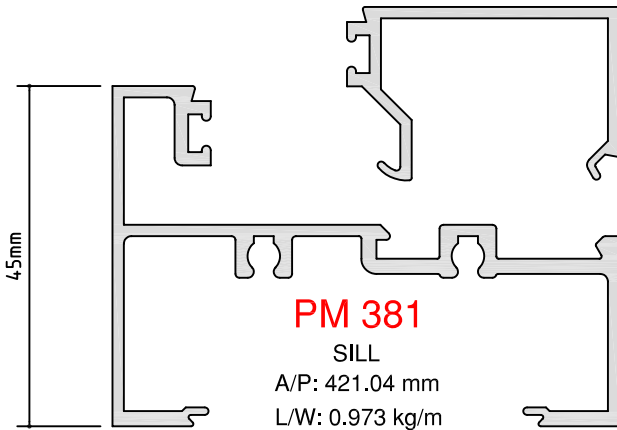
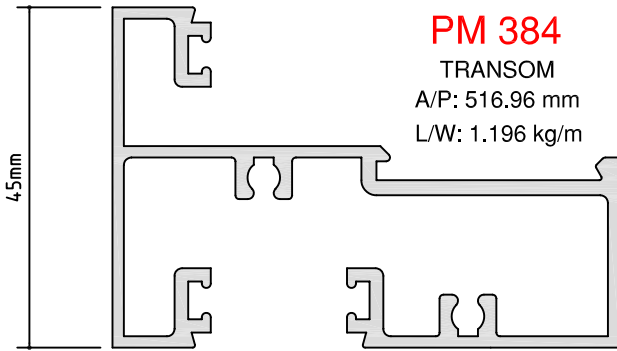
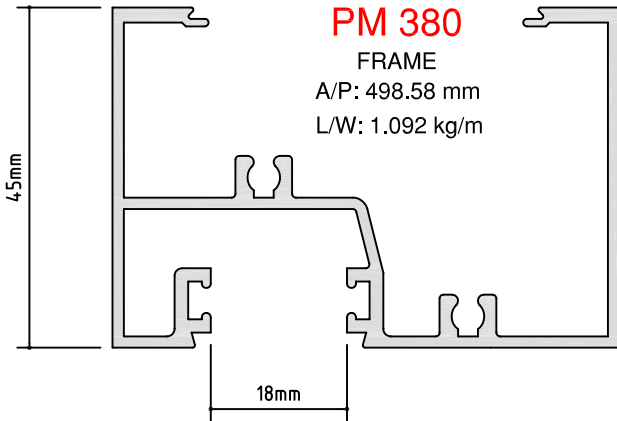

SCALE 1:1

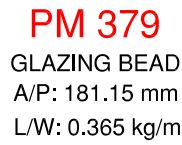
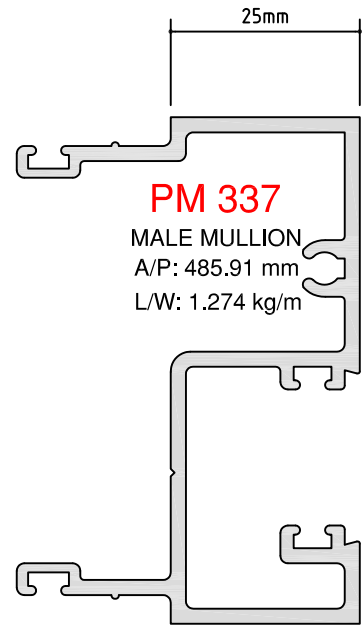
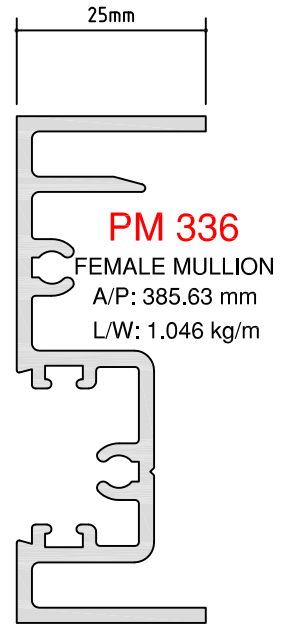

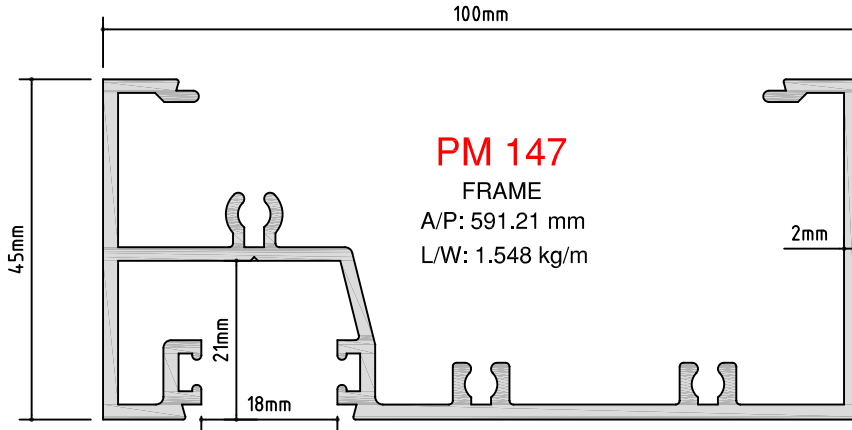

SCALE 1:1

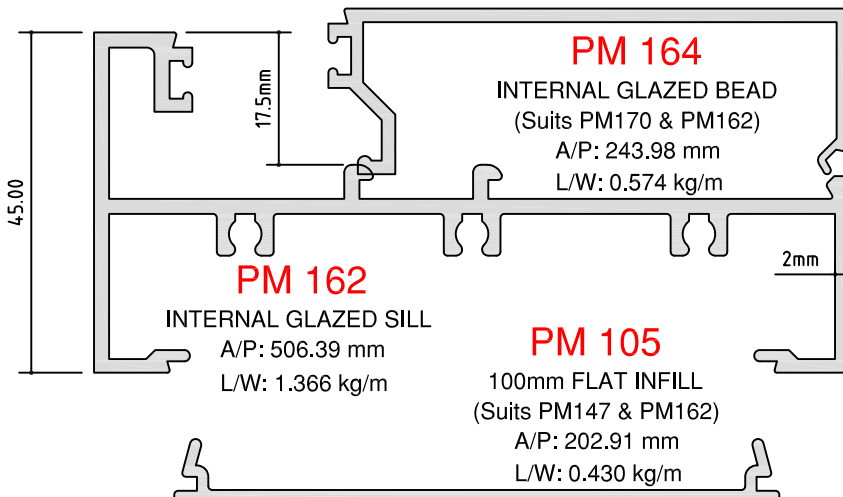
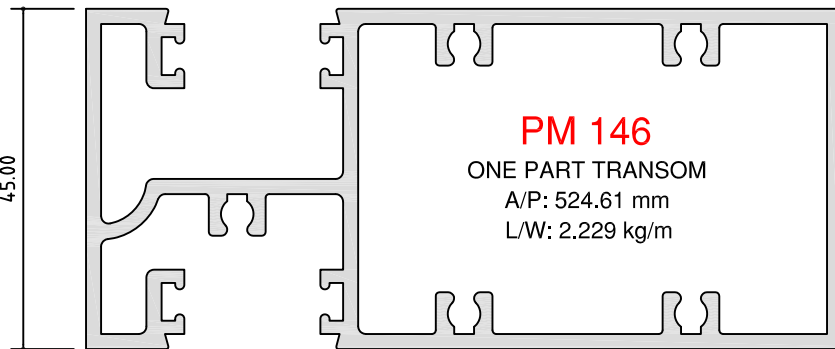
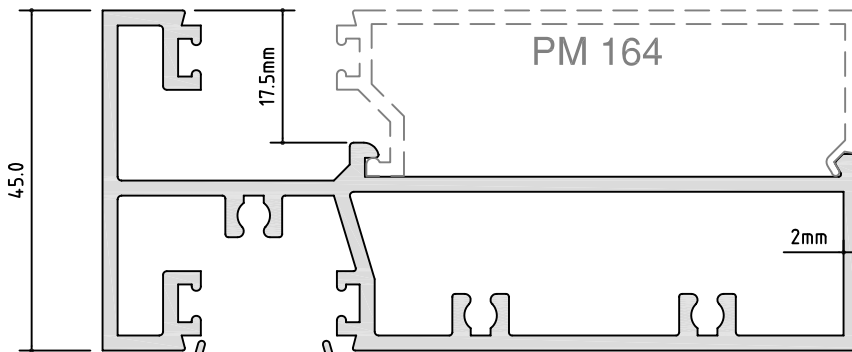

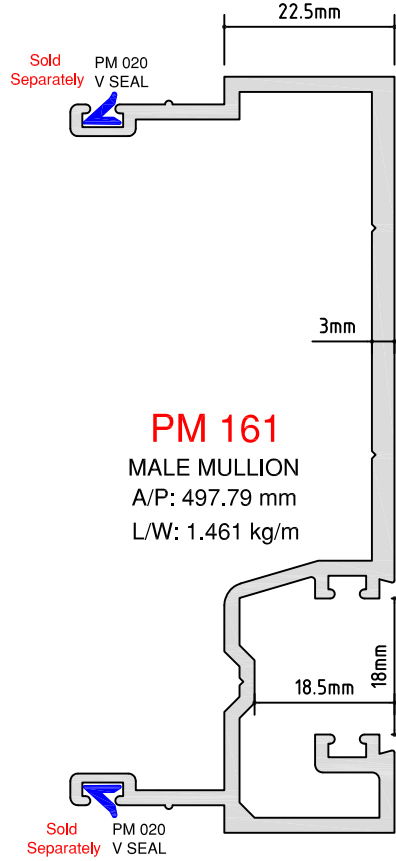
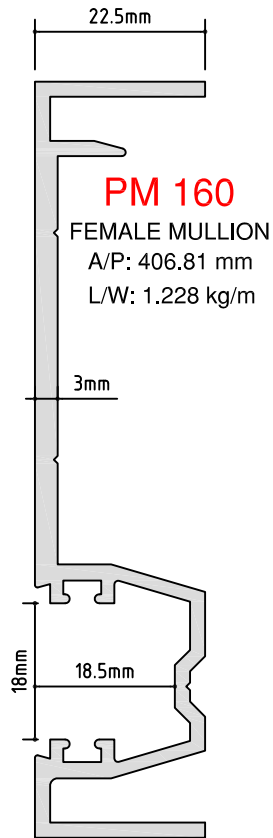

SCALE 1:1

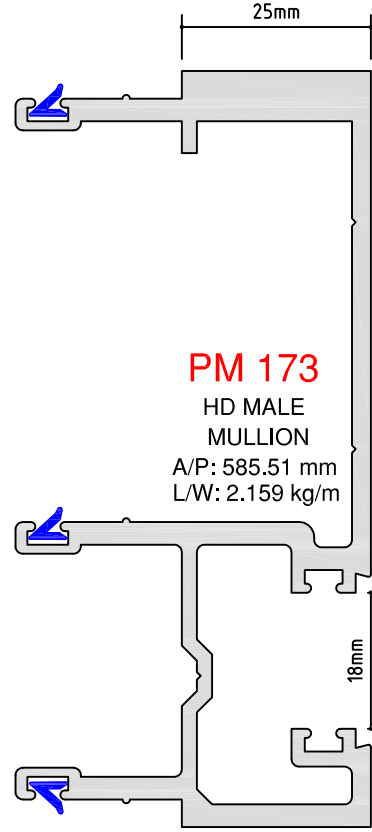
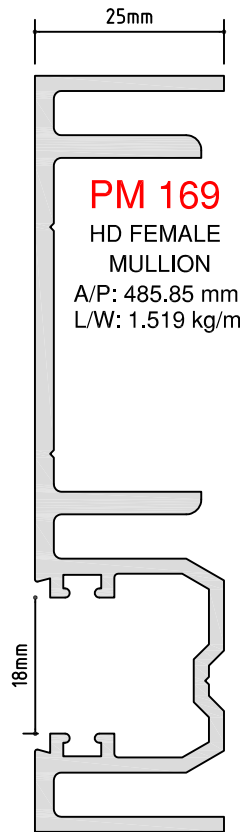

CAPTIVE WEDGES

PM000 PM001 PM002 PM003



ROLL IN WEDGES

PM004 PM005 PM006 PM007 PM008 PM009



ROLL IN WEDGE + ROLL IN WEDGE

Glass Thickness	Roll-in Wedge	Roll-in Wedge
18mm Pocket		
6.00mm	PM 006	PM 006
6.38mm	PM 006	PM 006
8.00mm	PM 007	PM 007
8.38mm	PM 007	PM 007
10.00mm	PM 005	PM 005
10.38mm	PM 005	PM 005
12.00mm	PM 008	PM 008
12.38mm	PM 008	PM 008

2002 - 2005 - 2006
SERIES

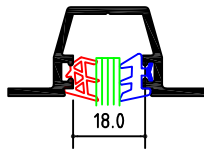

CAPTIVE WEDGE + ROLL IN WEDGE

Glass Thickness	Captive Wedge	Roll-in Wedge
18mm Pocket		
6.00mm	PM 001	PM 006
6.38mm	PM 001	PM 006
8.00mm	PM 002	PM 007
8.38mm	PM 002	PM 007
10.00mm	PM 003	PM 008
10.38mm	PM 003	PM 008
12.00mm	PM 003	PM 008
12.38mm	PM 003	PM 008

ROLL IN WEDGE + ROLL IN WEDGE

Glass Thickness	Roll-in Wedge	Roll-in Wedge
14.5mm Pocket		
5.00mm	PM 007	PM 006
6.00mm	PM 007	PM 007
6.38mm	PM 007	PM 007
8.00mm	PM 008	PM 007
8.38mm	PM 008	PM 007
10.00mm	PM 008	PM 008
10.38mm	PM 008	PM 008

2007 ME2 SERIES

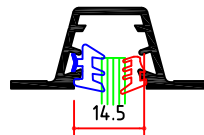

CAPTIVE WEDGE + ROLL IN WEDGE

Glass Thickness	Captive Wedge	Roll-in Wedge
14.5mm Pocket		
5.00mm	PM 001	PM 006
6.00mm	PM 001	PM 007
6.38mm	PM 001	PM 007
8.00mm	PM 002	PM 007
8.38mm	PM 002	PM 007
10.00mm	PM 003	PM 008
10.38mm	PM 003	PM 008



ROLL IN WEDGE + ROLL IN WEDGE

Glass Thickness	Roll-in Wedge	Roll-in Wedge
23mm Pocket		
6.00mm	PM009	PM009
6.38mm		
10.00mm	PM004	PM004
10.38mm		
12.00mm	PM006	PM007
12.50mm		
14mm DGU	PM005	PM007
16mm DGU	PM005	PM005
18mm DGU	PM008	PM008

2001 SERIES

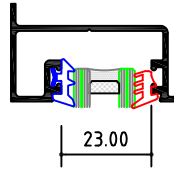

CAPTIVE WEDGE + ROLL IN WEDGE

Glass Thickness	Captive Wedge	Roll-in Wedge
23mm Pocket		
6.00mm	PM000	PM009
6.38mm		
10.00mm	PM001	PM004
10.38mm		
12.00mm	PM001	PM007
12.50mm		
14mm DGU	PM002	PM006
16mm DGU	PM002	PM005
18mm DGU	PM003	PM008

ROLL IN WEDGE + ROLL IN WEDGE 2003 - 2005 - 2008 8000 DG SERIES **CAPTIVE WEDGE + ROLL IN WEDGE**

Glass Thickness	Roll-in Wedge	Roll-in Wedge
32mm Pocket		
18.00mm	PM004	PM006
20.00mm	PM004	PM007
22.00mm	PM006	PM006
24.00mm	PM006	PM007
26.00mm	PM007	PM007
28.00mm	PM008	PM008

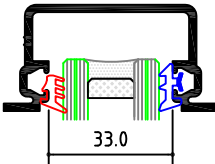
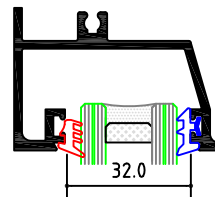

Glass Thickness	Captive Wedge	Roll-in Wedge
32mm Pocket		
18.00mm	PM001	PM004
20.00mm	PM001	PM006
22.00mm	PM001	PM007
24.00mm	PM 002	PM 007
26.00mm	PM002	PM007
28.00mm	PM003	PM008

ROLL IN WEDGE + ROLL IN WEDGE

Glass Thickness	Roll-in Wedge	Roll-in Wedge
35mm Pocket		
18.00mm	PM009	PM009
22.00mm	PM004	PM004
24.00mm	PM006	PM006
26.00mm	PM007	PM007
28.00mm	PM005	PM005
30.00mm	PM008	PM008

9000 SERIES

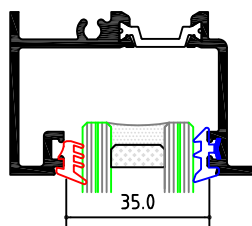

CAPTIVE WEDGE + ROLL IN WEDGE

Glass Thickness	Captive Wedge	Roll-in Wedge
35mm Pocket		
18.00mm	PM000	PM009
22.00mm	PM000	PM004
24.00mm	PM001	PM006
26.00mm	PM001	PM007
28.00mm	PM002	PM005
30.00mm	PM003	PM008



3000 SERIES SASH GLAZING CHANNELS

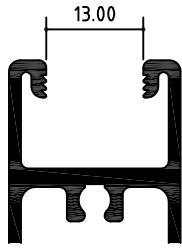

PM028

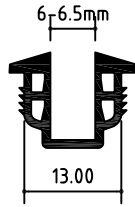

PM030

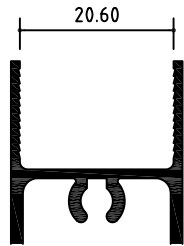
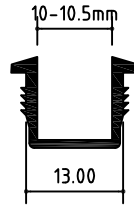

PM0011

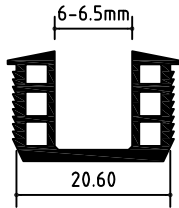

PM0012

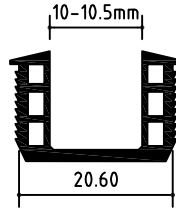

PM0013

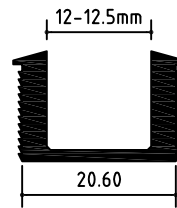

PM0014

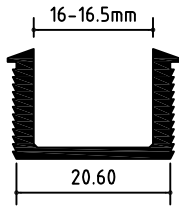

PM0015

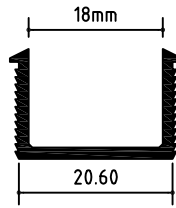

PM0016

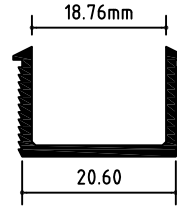

8000 - 9000 SERIES SASH GLAZING CHANNELS

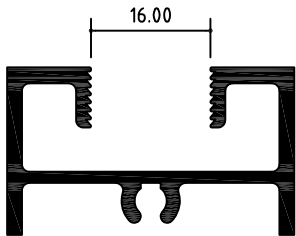

PM 032

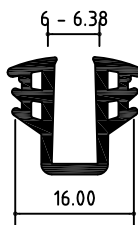

PM 076

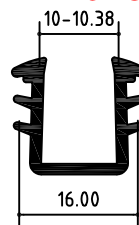

PM 062

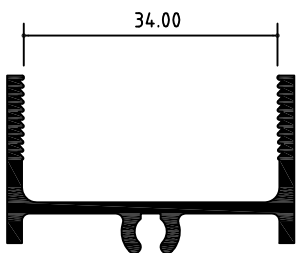
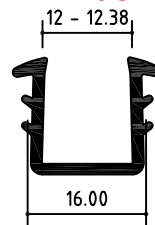

PM 079

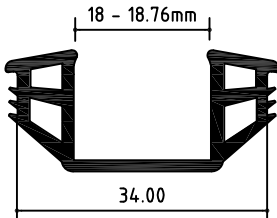

PM 045

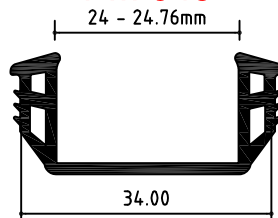

PM 046

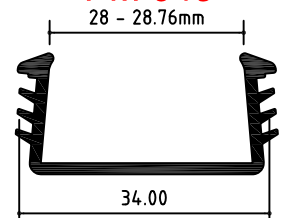



PM017 BI-FOLD STILE BULB

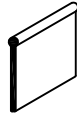

PM019 15mm SILL FLAP

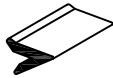

PM020 V - SEAL

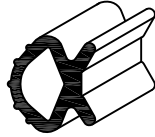

PM021 DOOR STOP BULB SEAL



PM025 FINNED BRUSH PILE 6.7 x 4.75



PM026 BI-FOLD FRAME SEAL

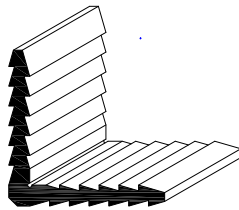

PM051 35mm AWNING SASH CORNER STAKE

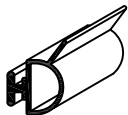

PM054 FINNED BULB SEAL



PM060 3000 SERIES CAP & PLUG SET
BLACK & GRAY

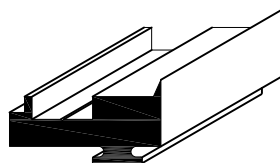

PM067 INTERLOCK ANTI LIFT BLOCK

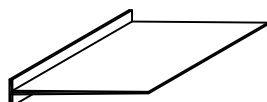

PM074 INTERLOCK FLAP SEAL



PM065 DORIC - DR2011 100kg DUAL ROLLER
(USE WITH 8000 & 9000 SERIES SLIDING DOORS)



PM065 ANTHONY INNOVATIONS - 9020 100kg DUAL ROLLER
(USE WITH 3000 SERIES SLIDING DOORS)

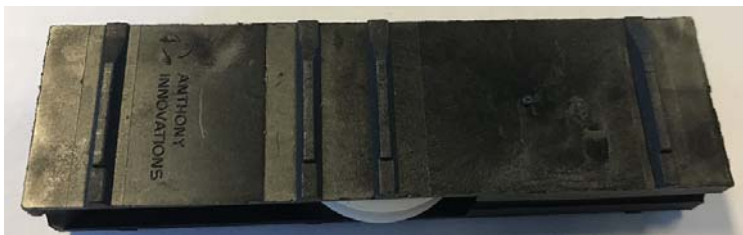

PM066 ANTHONY INNOVATIONS - 5006 50kg SINGLE ROLLER
(USE WITH 3000 SERIES SLIDING WINDOWS)

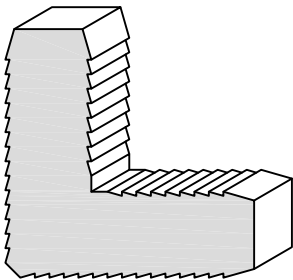

PM0021 50mm AWNING SASH CORNER STAKE

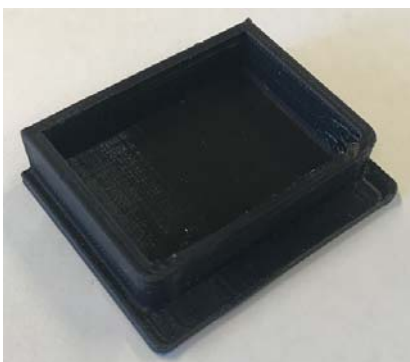

PM075 8000 & 9000 Series Stile Caps

EQUAL ANGLES

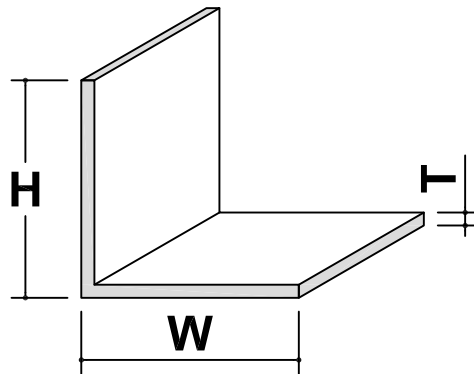

ITEM CODE	H	x	W	x	T	LENGTH
AN121215	12		12		1.5	6500
AN202015	20		20		1.5	6500
AN202030	20		20		3.0	6500
AN252515	25		25		1.5	6500
AN252530	25		25		3.0	6500
AN323215	32		32		1.5	6500
AN323230	32		32		3.0	6500
AN404015	40		40		1.5	6500
AN404030	40		40		3.0	6500
AN404060	40		40		6.0	6500
AN505015	50		50		1.5	6500
AN505030	50		50		3.0	6500
AN505060	50		50		6.0	6500
AN606060	60		60		6.0	6500
AN757530	75		75		3.0	6500
AN808060	80		80		6.0	6500
AN10010010	100		100		10.0	5600

UNEQUAL ANGLES

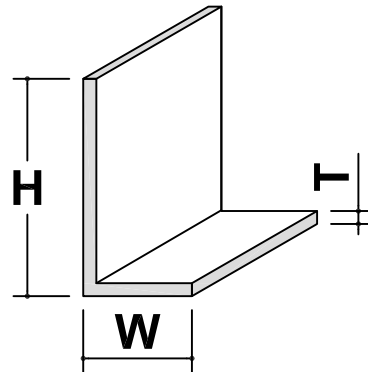

ITEM CODE	H x W x T	LENGTH
AN201215	20 x 12 x 1.5	6500
AN251215	25 x 12 x 1.5	6500
AN252015	25 x 20 x 1.5	6500
AN322015	32 x 20 x 1.5	6500
AN402015	40 x 20 x 1.5	6500
AN402030	40 x 20 x 3.0	6500
AN402515	40 x 25 x 1.5	6500
AN402530	38.1 x 25.4 x 2.9	6500
AN502015	50 x 25 x 1.5	6500
AN502530	50 x 25 x 3.0	6500
AN1005060	100 x 50 x 6.0	6500
AN1255030	125 x 50 x 3.0	6500

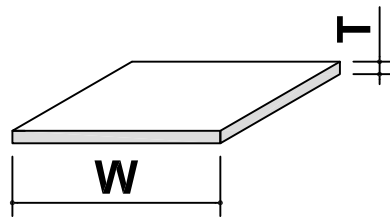

ITEM CODE	W	x	T	LENGTH
FB1030	10		3.0	4000
FB1216	12		1.6	4000
FB1230	12		3.0	4000
FB1630	16		3.0	4000
FB2016	20		1.6	4000
FB2030	20		3.0	4000
FB2060	20		6.0	4000
FB2516	25		1.6	4000
FB2530	25		3.0	4000
FB2560	25		6.0	4000
FB2510	25		10.0	4000
FB3230	32		3.0	4000
FB3260	32		6.0	4000
FB3210	32		10.0	4000
FB4030	40		3.0	4000
FB4060	40		6.0	4000
FB4010	40		10.0	4000
FB5030	50		3.0	4000
FB5060	50		6.0	4000
FB5010	50		10.0	4000
FB6030	60		3.0	4000
FB6010	60		10.0	4000
FB8060	80		6.0	4000
FB8010	80		10.0	4000
FB10030	100		3.0	4000
FB10060	100		6.0	4000
FB10010	100		10.0	4000
FB16010	160		10.0	4000

CHANNELS

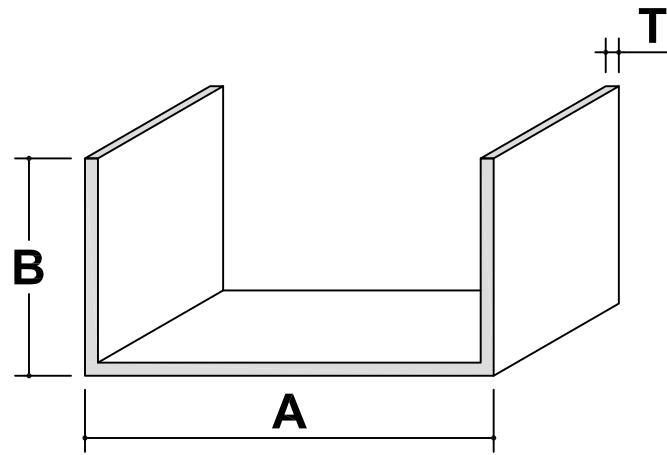

ITEM CODE	A	x	B	x	T	LENGTH
CH121216	12		12		1.6	6000
CH161616	16		16		1.6	6000
CH202015	20		20		1.5	5600
CH202030	20		20		3.0	6500
CH252516	25		25		1.6	6500
CH252530	25		25		3.0	6500
CH255028	25		50		2.8	5400
CH402020	40		20		2.0	6500
CH402030	40		20		3.0	6500
CH402030	40		25		3.0	6500
CH442530	44		25		3.0	6500
CH442820	44.45		28.58		1.98	6500
CH502014	50		20		1.4	6500
CH502530	50		25		3.0	6500
AWN50463	56		40		2.0	6500
CH575030	57.1		50.2		3.0	6500
CH804030	80		40		3.0	6500
CH1002530	100		25		3.0	6500

SQUARE BOX

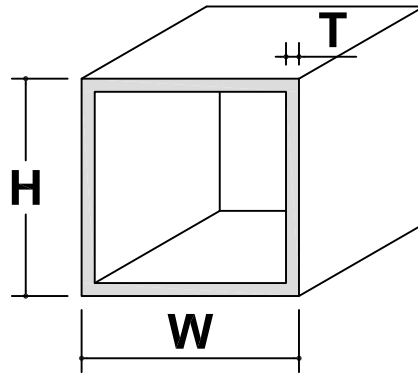

ITEM CODE	H	x	W	x	T	LENGTH
BX121216	12		12		1.5	6500
BX191912	19		19		1.2	6500
BX191915	19		19		1.6	6500
BX202016	20		20		1.6	6500
BX202030	20		20		3.0	6500
BX252516	25		25		1.6	6500
BX252530	25		25		3.0	6500
BX323216	32		32		1.6	6500
BX323230	32		32		3.0	6500
BX404016	40		40		1.6	6500
BX404020	40		40		2.0	6500
BX404025	40		40		2.5	6500
BX404030	40		40		3.0	6500
BX505020	50		50		2.0	6500
BX505025	50		50		2.5	6500
BX505030	50		50		3.0	6500
BX656525	65		65		2.5	4900
BX656525	65		65		2.5	6500
BX10010030	100		100		3.0	6500

RECTANGLE BOX

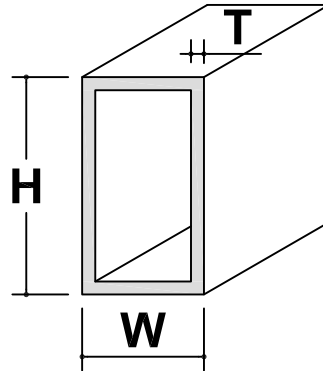

ITEM CODE	H	x	W	x	T	LENGTH
BX402525	38.1		25.4		2.5	6500
BX502525	50		25		2.5	6500
BX502528	50		25		2.8	6500
BX504025	50		40		2.5	6500
BX604030	60		40		3.0	6500
BX762520	76.2		25.4		2.0	6500
BX804030	80		40		3.0	6500
BX805030	80		50		3.0	6500
BX1005015	100		50		1.5	6500
BX1004520	100		45		2.0	6500
BX1005030	100		50		3.0	6500
BX1012514	101.6		25.4		1.4	6000
BX1505030	150		50		3.0	6500
BX2005030	200		50		3.0	6500

RADIUS BOX

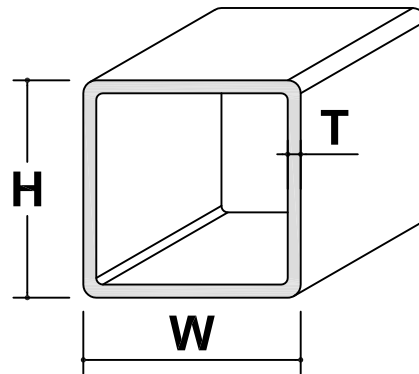

ITEM CODE	H	x	W	x	T	LENGTH
BX191915RC	19		19		1.5	6500
BX252512RC	25.4		25.4		1.2	6500
BX252516RC	25		25		1.6	6500
BX252520RC	25		25		2.0	6500
BX252530RC	25		25		3.0	6500
BX323225RC	31.7		31.7		2.5	6500
BX323220RC	32		32		2.0	6010
BX404030RC	40		40		3.0	6500
BX505018RC	50		50		1.8	1800
BX505018RC	50		50		1.8	2100
BX505020RC	50		50		2.0	5400
BX505020RC	50		50		2.0	6500
BX656525RC	65		65		2.5	4900
BX656525RC	65		65		2.5	6500
BX757528RC	75		75		2.8	6500
BX10010030RC	100		100		3.0	2400

RADIUS BOX

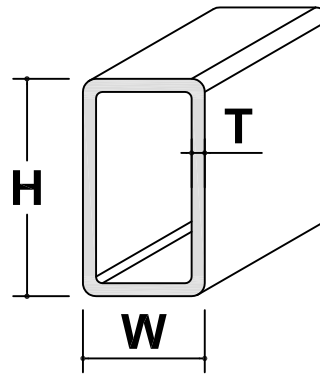

ITEM CODE	H	x	W	x	T	LENGTH
BX371612RC	37		16		1.2	6500
BX382515RC	38		25		1.5	5000
BX382515RC	38		25		1.5	6500
BX502516RC	50		25		1.6	6500
BX502530RC	50		25		3.0	6500
BX651612RC	65		16		1.2	6500
BX651614RC	65		16		1.4	6500
BX804030RC	80		40		3.0	6000
BX1001612RC	100		16		1.2	6500
BX1005030RC	100		50		3.0	6500
BX1505030RC	150		50		3.0	6500

ROUND TUBE

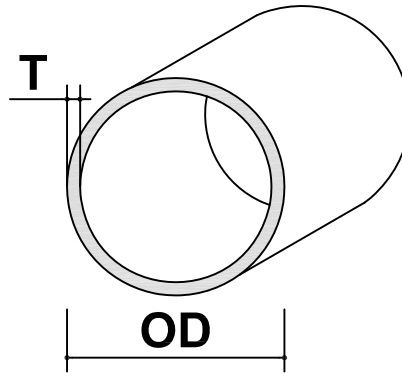

ITEM CODE	OD	x	T	LENGTH
TU1216	12		1.6	6000
TU158812	15.88		1.22	1195
TU158812	15.88		1.22	6000
TU1616	16		1.6	1195
TU1616	16		1.6	6000
TU1912	19		1.2	1195
TU1912	19		1.2	6200
TU2016	20		1.6	6500
TU2512	25		1.2	6000
TU2516	25		1.6	6000
TU2530	25		3.0	6000
TU3230	32		3.0	6000
TU3230	32		3.0	6500
TU4016	40		1.6	6000
TU4030	40		3.0	6000
TU5020	50		2.0	6000
TU5030	50		3.0	6000
TU6020	60		2.0	6000
TU6030	60		3.0	6000
TU7632	76.2		3.25	6500
TU7647	76.2		4.75	6000

INDEX

CODE	PAGE NUMBERS
PM100	Pg-14
PM102	Pg-14
PM103	Pg-14
PM105	Pg-17,21,62,95
PM106	Pg-15
PM107	Pg-16
PM108	Pg-16
PM109	Pg-16
PM110	Pg-14
PM111	Pg-15
PM112	Pg-16
PM113	Pg-16
PM114	Pg-17,21,62,96
PM115	Pg-17,21
PM116	Pg-17,21,23,68
PM117	Pg-17
PM118	Pg-16,62
PM119	Pg-30,81
PM120	Pg-30,80,101
PM121	Pg-30,101
PM122	Pg-16,34
PM123	Pg-16,34
PM124	Pg-16,34
PM126	Pg-31
PM127	Pg-31,47
PM128	Pg-27,29,31,47
PM129	Pg-31,47
PM134	Pg-27
PM135	Pg-17
PM139	Pg-04
PM140	Pg-04
PM141	Pg-04,06,10,56
PM142	Pg-03
PM143	Pg-03
PM144	Pg-03
PM145	Pg-02
PM146	Pg-112
PM147	Pg-112
PM154	Pg-03
PM160	Pg-113
PM161	Pg-113
PM162	Pg-112
PM164	Pg-112
PM167	Pg-14
PM168	Pg-14
PM169	Pg-113
PM170	Pg-112
PM173	Pg-113
PM183	Pg-24,69
PM184	Pg-24,69
PM185	Pg-24
PM186	Pg-24
PM187	Pg-26
PM188	Pg-26,70
PM189	Pg-26

CODE	PAGE NUMBERS
PM191	Pg-23,28,42
PM193	Pg-27,70
PM196	Pg-25
PM197	Pg-25
PM198	Pg-25
PM200	Pg-27
PM201	Pg-27
PM203	Pg-27
PM206	Pg-67
PM209	Pg-67
PM210	Pg-68
PM211	Pg-67
PM213	Pg-67
PM214	Pg-67
PM218	Pg-69
PM219	Pg-69
PM220	Pg-68
PM222	Pg-31,47
PM223	Pg-31,47
PM224	Pg-02,67
PM225	Pg-68
PM229	Pg-21,23
PM234	Pg-18
PM235	Pg-18
PM236	Pg-18
PM237	Pg-18
PM238	Pg-18
PM239	Pg-18
PM247	Pg-65
PM248	Pg-65
PM250	Pg-73
PM251	Pg-73
PM252	Pg-74
PM-253	Pg-74
PM-254	Pg-74
PM-255	Pg-74
PM-256	Pg-19,74,76,81
PM257	Pg-82
PM258	Pg-74
PM260	Pg-73
PM261	Pg-20
PM262	Pg-112
PM264	Pg-52
PM265	Pg-73
PM266	Pg-73
PM267	Pg-05
PM269	Pg-05
PM270	Pg-54,75
PM272	Pg-75
PM273	Pg-75
PM274	Pg-75
PM275	Pg-76
PM276	Pg-76
PM278	Pg-75
PM280	Pg-52

CODE	PAGE NUMBERS
PM287	Pg-11
PM288	Pg-11
PM289	Pg-11
PM291	Pg-20,22
PM292	Pg-76
PM293	Pg-76
PM294	Pg-03
PM296	Pg-08
PM297	Pg-07
PM298	Pg-30,81
PM299	Pg-07
PM300	Pg-07
PM302	Pg-08
PM307	Pg-54
PM308	Pg-23,84
PM317	Pg-22
PM322	Pg-16,34
PM323	Pg-27
PM324	Pg-27
PM326	Pg-10,56
PM327	Pg-10,56
PM331	Pg-17
PM335	Pg-49
PM336	Pg-112
PM337	Pg-112
PM341	Pg-50
PM342	Pg-25
PM344	Pg-47,97
PM345	Pg-24,69
PM346	Pg-24
PM347	Pg-25
PM348	Pg-26,70
PM349	Pg-26,70
PM350	Pg-27,70
PM351	Pg-27
PM355	Pg-74
PM356	Pg-76
PM369	Pg-58
PM371	Pg-56
PM372	Pg-55
PM373	Pg-55
PM375	Pg-56
PM376	Pg-55
PM379	Pg-112
PM380	Pg-112
PM381	Pg-112
PM384	Pg-112
PM385	Pg-01,50
PM386	Pg-01,50
PM387	Pg-13
PM389	Pg-112
PM395	Pg-12
PM396	Pg-58
PM397	Pg-59
PM398	Pg-51

INDEX

CODE	PAGE NUMBERS
PM399	Pg-51
PM400	Pg-52
PM401	Pg-51
PM404	Pg-54,60
PM405	Pg-60
PM406	Pg-51
PM407	Pg-58
PM409	Pg-58
PM410	Pg-58
PM411	Pg-15
PM412	Pg-51
PM413	Pg-58
PM414	Pg-58
PM415	Pg-58
PM416	Pg-60
PM417	Pg-52
PM418	Pg-58
PM419	Pg-58
PM420	Pg-58
PM421	Pg-58
PM422	Pg-59
PM423	Pg-59
PM424	Pg-58
PM425	Pg-59
PM426	Pg-59
PM427	Pg-59
PM428	Pg-53
PM429	Pg-54
PM432	Pg-52
PM434	Pg-58
PM436	Pg-53
PM437	Pg-54
PM438	Pg-50
PM439	Pg-50
PM440	Pg-60
PM444	Pg-60
PM445	Pg-60,83
PM446	Pg-60
PM447	Pg-60
PM448	Pg-60
PM487	Pg-60
PM488	Pg-60
PM612	Pg-64
PM614	Pg-64
PM615	Pg-64
PM616	Pg-64
PM617	Pg-64
PM618	Pg-63
PM619	Pg-63
PM620	Pg-63
PM621	Pg-63
PM622	Pg-61
PM623	Pg-63
PM624	Pg-63
PM628	Pg-63

CODE	PAGE NUMBERS
PM629	Pg-63
PM630	Pg-63
PM631	Pg-63
PM635	Pg-64
PM637	Pg-63
PM655	Pg-92
PM656	Pg-83
PM657	Pg-92,107
PM658	Pg-92
PM662	Pg-85
PM663	Pg-85
PM666	Pg-82
PM670	Pg-83
PM671	Pg-82
PM672	Pg-83
PM673	Pg-82
PM674	Pg-82
PM675	Pg-82
PM676	Pg-84
PM678	Pg-84
PM679	Pg-84
PM680	Pg-84
PM681	Pg-83
PM682	Pg-92,107
PM683	Pg-92,107
PM684	Pg-92
PM685	Pg-92,107
PM686	Pg-90
PM687	Pg-90
PM688	Pg-90
PM689	Pg-90
PM690	Pg-90
PM691	Pg-90
PM692	Pg-90,91
PM693	Pg-90,91
PM694	Pg-90,91
PM695	Pg-90,91
PM700	Pg-38
PM706	Pg-02
PM707	Pg-38
PM709	Pg-38,40
PM710	Pg-33
PM712	Pg-39
PM713	Pg-38
PM714	Pg-39
PM715	Pg-39
PM720	Pg-04
PM721	Pg-21,23,28,81,101
PM722	Pg-21,23,28,81,101
PM725	Pg-91
PM726	Pg-91
PM727	Pg-91
PM728	Pg-91
PM737	Pg-41
PM738	Pg-41
PM739	Pg-40

CODE	PAGE NUMBERS
PM741	Pg-92,107
PM742	Pg-92,107
PM743	Pg-92,107
PM744	Pg-92,107
PM745	Pg-03
PM746	Pg-02
PM747	Pg-01
PM748	Pg-49
PM750	Pg-49
PM751	Pg-49
PM752	Pg-49
PM753	Pg-49
PM755	Pg-50
PM757	Pg-12
PM758	Pg-12
PM759	Pg-12
PM760	Pg-12
PM761	Pg-13
PM762	Pg-13
PM763	Pg-12
PM764	Pg-12,50
PM765	Pg-12
PM766	Pg-57
PM767	Pg-57
PM768	Pg-57
PM769	Pg-57
PM770	Pg-57
PM771	Pg-57
PM772	Pg-57
PM773	Pg-57
PM774	Pg-57
PM775	Pg-57
PM776	Pg-57
PM785	Pg-41
PM786	Pg-40
PM787	Pg-38
PM788	Pg-41
PM789	Pg-57
PM790	Pg-03
PM791	Pg-39
PM792	Pg-39
PM793	Pg-38
PM794	Pg-38
PM795	Pg-40
PM796	Pg-07
PM797	Pg-38
PM798	Pg-02
PM800	Pg-86
PM801	Pg-86
PM802	Pg-86
PM803	Pg-86
PM804	Pg-87
PM805	Pg-87
PM806	Pg-87
PM807	Pg-86
PM808	Pg-87

INDEX

CODE	PAGE NUMBERS
PM810	Pg-88
PM811	Pg-88
PM812	Pg-88
PM813	Pg-88
PM814	Pg-89
PM815	Pg-89
PM816	Pg-89
PM817	Pg-88
PM818	Pg-89
PM819	Pg-83
PM820	Pg-83
PM822	Pg-28,80
PM823	Pg-29,72,80
PM824	Pg-28,71,80
PM825	Pg-28,71,80
PM826	Pg-29,72,80
PM827	Pg-29,72,80
PM830	Pg-78
PM831	Pg-78
PM832	Pg-78
PM833	Pg-79
PM834	Pg-79
PM835	Pg-79
PM836	Pg-29,72,80
PM837	Pg-29,72,80
PM838	Pg-77
PM839	Pg-47,77
PM840	Pg-77
PM841	Pg-77
PM842	Pg-48,77
PM843	Pg-48,77
PM844	Pg-48,77
PM858	Pg-30,81,101
PM859	Pg-21,23
PAR100	Pg-108
PAR101	Pg-108
PAR102	Pg-108
PAR103	Pg-108
PAR104	Pg-108
PAR105	Pg-109
PAR106	Pg-109
PAR107	Pg-109
PAR108	Pg-109,111
PAR109	Pg-109
PAR110	Pg-109
PAR111	Pg-109
PAR200	Pg-110
PAR201	Pg-110
PAR202	Pg-110
PAR203	Pg-110
PAR204	Pg-110
PAR205	Pg-111
PAR206	Pg-111
PAR207	Pg-111
PAR208	Pg-111
PAR209	Pg-111
PAR210	Pg-111
PAR211	Pg-111

CODE	PAGE NUMBERS
PATH100	Pg-93
PATH101	Pg-93
PATH102	Pg-93
PATH103	Pg-93
PATH104	Pg-94
PATH105	Pg-94
PATH106	Pg-94
PATH107	Pg-94
PATH110	Pg-98
PATH111	Pg-98
PATH112	Pg-98
PATH115	Pg-06
PATH121	Pg-97
PATH122	Pg-97
PATH123	Pg-97
PATH126	Pg-95
PATH127	Pg-95
PATH128	Pg-95
PATH129	Pg-95
PATH130	Pg-99
PATH131	Pg-99
PATH132	Pg-99
PATH133	Pg-96
PATH134	Pg-96
PATH135	Pg-96
PATH138	Pg-09
PATH143	Pg-94
PATH149	Pg-105
PATH150	Pg-105
PATH151	Pg-106
PATH152	Pg-106
PATH153	Pg-106
PATH154	Pg-106
PATH155	Pg-106
PATH156	Pg-107
PATH158	Pg-107
PATH159	Pg-102
PATH160	Pg-103
PATH161	Pg-102
PATH162	Pg-102
PATH163	Pg-103
PATH164	Pg-103
PATH165	Pg-103
PATH166	Pg-106
PATH168	Pg-104
PATH169	Pg-104
PATH170	Pg-105
PATH171	Pg-104
PATH177	Pg-93
PATH180	Pg-100
PATH181	Pg-100
PATH182	Pg-100
PATH183	Pg-101
PATH185	Pg-100

CODE	PAGE NUMBERS
ME2-0001	Pg-32
ME2-0012	Pg-43
ME2-0263	Pg-42
ME2-0269	Pg-43
ME2-0361	Pg-33
ME2-0413	Pg-43
ME2-0707	Pg-36
ME2-0717	Pg-36
ME2-07819	Pg-45
ME2-07820	Pg-45
ME2-07821	Pg-45
ME2-07822	Pg-45
ME2-07823	Pg-45
ME2-07824	Pg-42
ME2-0810	Pg-35
ME2-0811	Pg-35
ME2-0812	Pg-35
ME2-0813	Pg-35
ME2-0931	Pg-45
ME2-0933	Pg-45
ME2-2000	Pg-32
ME2-20222	Pg-32
ME2-20223	Pg-32
ME2-20224	Pg-33
ME2-20225	Pg-33
ME2-20226	Pg-33
ME2-20227	Pg-33
ME2-20228	Pg-34
ME2-20229	Pg-33
ME2-20230	Pg-35
ME2-20231	Pg-35
ME2-20232	Pg-35
ME2-20233	Pg-35
ME2-20234	Pg-34
ME2-20235	Pg-34
ME2-20237	Pg-35
ME2-20238	Pg-35
ME2-20239	Pg-33,52
ME2-342	Pg-33
ME2-3646	Pg-42
ME2-3648	Pg-42
ME2-3651	Pg-44
ME2-3652	Pg-44
ME2-3654	Pg-44
ME2-4679	Pg-36
ME2-4899	Pg-35
ME2-4976	Pg-36
ME2-50848	Pg-32
ME2-51289	Pg-36
ME2-51290	Pg-36
ME2-51291	Pg-36
ME2-51292	Pg-36
ME2-51293	Pg-44
ME2-51294	Pg-42
ME2-51295	Pg-42
ME2-5150	Pg-46

INDEX

CODE	PAGE NUMBERS
ME2-5151	Pg-46
ME2-51691	Pg-43
ME2-51692	Pg-43
ME2-51693	Pg-43
ME2-51694	Pg-44
ME2-51696	Pg-44
ME2-51697	Pg-42

CODE	PAGE NUMBERS
ME2-5170	Pg-46
ME2-51715	Pg-04
ME2-5171	Pg-46
ME2-51726	Pg-42
ME2-52097	Pg-37
ME2-52098	Pg-37
ME2-52099	Pg-37

CODE	PAGE NUMBERS
ME2-52100	Pg-37
ME2-52101	Pg-37
ME2-52102	Pg-37
ME2-52103	Pg-37
ME2-52104	Pg-37
ME2-52105	Pg-37
ME2-52513	Pg-44
ME2-7886	Pg-36



**PRESS METAL
ALUMINIUM**

TECHNICAL CATALOGUES

**PRESS METAL
ALUMINIUM** **2000 SERIES**
WINDOWS and DOORS

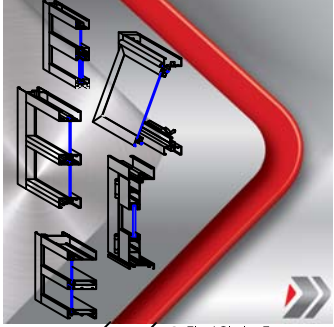



- Fixed Glazing Frames
- Awning Sash
- Commercial Hinged Door
- Sub Frames

AUSTRALIAN DESIGNED AND TESTED

**PRESS METAL
ALUMINIUM** **3000 SERIES**
SLIDING WINDOWS
SLIDING DOORS



SINGLE or DOUBLE GLAZING

SUPPORTED BY:



**PRESS METAL
ALUMINIUM** **6000 SERIES**
Fixed and Adjustable Blade
LOUVRE SYSTEMS





**PRESS METAL
ALUMINIUM** **7000 SERIES**



BI-FOLDING

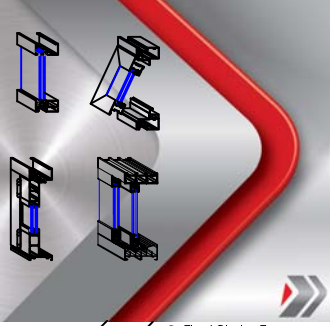

WINDOWS AND DOORS
"Single & Double Glazing"

**PRESS METAL
ALUMINIUM** **8000 SERIES**
PREMIER WINDOWS
and DOORS



- Fixed Glazing Frames
- Awning Top Hung Sash
- Commercial Hinged Door
- Sliding Doors and Windows

AUSTRALIAN DESIGNED AND TESTED

SUPPORTED BY:



path - 9000 SERIES
thermal break window system



**PRESS METAL
ALUMINIUM** COMMERCIAL CATALOGUE
WINDOWS & DOORS

MEMBER OF THE AUSTRALIAN
GLASS & WINDOW ASSOCIATION



SUPPORTED BY:

